



ottomotores

# PERKINS SERIE 1104

Energía que Mueve al Mundo

## Definiciones

### Potencia Prime

Estos valores son aplicables para el suministro de energía eléctrica continua (a carga variable) en lugar de la red comercial.

### Potencia Stand by

Estos valores son aplicables para el suministro de energía eléctrica continua (a carga variable) en caso de falla de la red comercial. No se permite sobrecarga sobre estos valores.

### Tabla de Potencias

Modelo	Voltaje	Prime kVA	Prime kW	Stand-by kVA	Stand-by kW
PNY80	220-440V	91	73	100	80
PNY100	220-440V	112	90	125	100

0.8 Factor de potencia

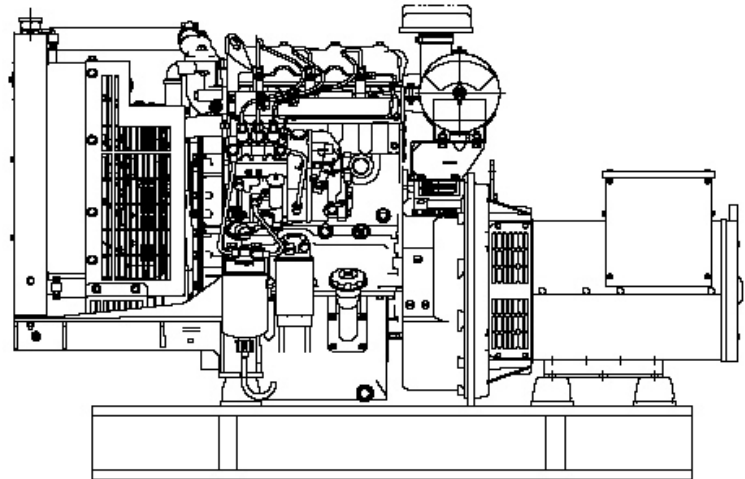

## Información Técnica

Datos Técnicos	PNY80	PNY100
Frecuencia:	60 Hz	60 Hz
Motor Marca / Modelo	Perkins 1104A-44TG2	Perkins 1104C-44TAG2
Generador Marca/Modelo:	Stamford UCI224G	Stamford UCI274C
Numero de polos del Generador:	4 polos	4 polos
Tipo de aislamiento del Generador:	Tipo H	Tipo H
Número de Cilindros del motor:	4 en línea	4 en línea
Diametro por Carrera :in ( mm)	4.13X4.99 (105X127)	4.13X4.99 (105X127)
Relación de Compresión:	17.25 : 1	18.2:1
Aspiración:	Turbocargado	Turbocargado
Velocidad:	1800 RPM	1800 RPM
Potencia del motor: kW/m	93.0	117.5
Presion Efectiva: Lbf/in <sup>2</sup> (kPA)	204.3 (1409)	163.0(1124)
Velocidad de Piston: ft/s (m/s)	25 (7.62)	25 (7.62)
Consumo de combustible: lt / hr - 100%	22.3	26.7
Calor Expulsado en el Sistema de Escape: kW	71.0	99.7
Calor Expulsado en el Sistema de Enfriamiento: kW	57.0	64.0
Temperatura de Escape: °C	560	574
Flujo de Enfriamiento en el Radiador m <sup>3</sup> /min	111.0	225.6
Flujo de Escape: m <sup>3</sup> /min	15.85	20.40
Dimensiones (Largo x Ancho x Alto)cm	202x68x123	202x76x123
Peso Aprox. humedo kg.	899	1001

Los equipos en foto pudieran incluir accesorios opcionales

Como leer nuestro codigo: Ejem: **PNY30**

P=Motor Perkins  
N=Generador Newage Stamford  
E=50Hz-1500 RPM  
Y=60Hz-1800 RPM  
30= Potencia del Equipo.



Energía que Mueve al Mundo



Ottomotores, S.A de C.V.

Calz. San Lorenzo No.1150  
Col. Cerro de la estrella, C.P. 09860  
Delg. Iztapalapa México, D.F.  
Tels:52-55-5624-5600

Fax: 52-55-5426-5521 / 52-55-5426-5581

ventas@ottomotores.com.mx

www.ottomotores.com.mx



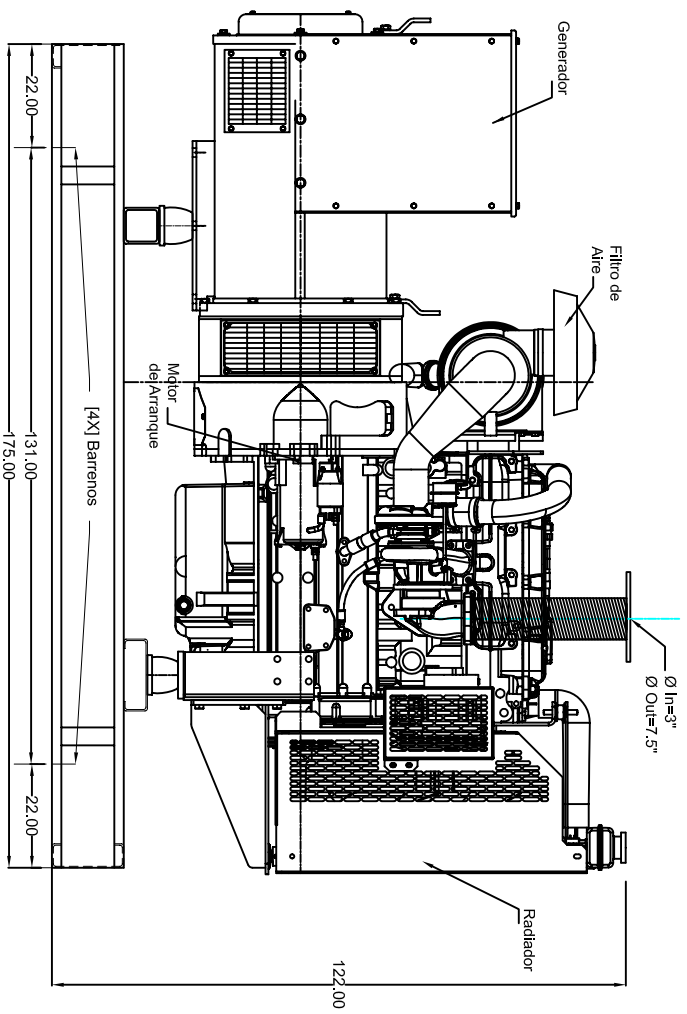

VISTA LATERAL

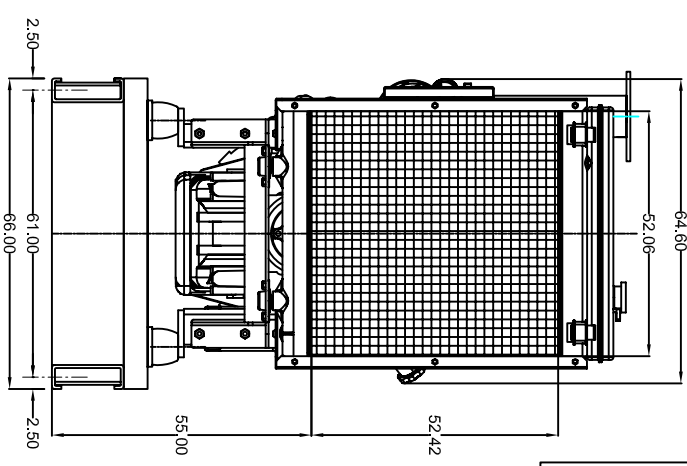

VISTA FRONTAL

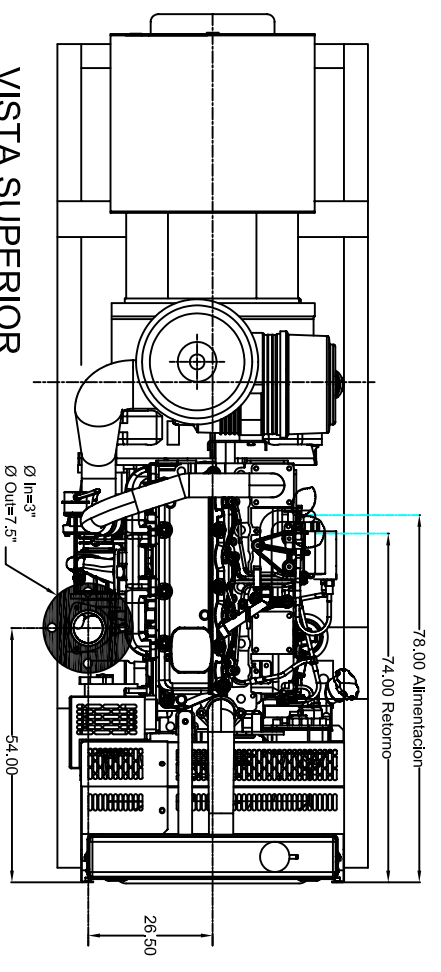

VISTA SUPERIOR

DESCRIPCION	
MOTOR:	1104A-44TG2
GENERATOR:	UC1224E
RADIADOR:	COOL PACK
BASE PATIN:	BMT-1104A-STF
PESO TOTAL:	Seco-832.00 Kgs. Humedo-854.00 Kgs.
No. AMORTIGUADORES:	4

Cliente: OTP:

Revisiones		Descripción		Fecha		Aprobado	
Rev							

Título: DIMENSIONES GENERALES MOTOR PERKINS 1104A-44TG2  
 GENERADOR STAMFORD 80 kW

Dibujó: ING. R.G.C.      Revisó: ING. R.G.C.      Aprobó: ING. V.F.F.      Cliente: DP-PRK04  
 Fecha: 07 Sep 2010      Fecha: 07 Sep 2010      Fecha: 07 Sep 2010      Dpto: Ingeniería



Acab.: oms      Plano: N/A  
 Esc.: 5/8      Dp.: N/A

ESTE DIBUJO ES UNO DE LOS DIBUJOS QUE INTEGRAN UN CONJUNTO DE DISEÑO Y FABRICACIÓN. LA COMERCIALIZACIÓN Y USO DE ESTE DIBUJO SIN EL CONSENTIMIENTO DE LA EMPRESA ES PROHIBIDO.

# Technical Data

## 1100 Series

Gen Set

# 1104A-44TG2

**79,1 kWm @ 1500 rev/min**

**90,2 kWm @ 1800 rev/min**

### Basic technical data

Number of cylinders	4
Cylinder arrangement	Vertical in-line
Cycle	Four stroke
Induction system	Turbocharged
Compression ratio	17.25 : 1
Bore	105 mm (4.13 in)
Stroke	127 mm (4.99 in)
Cubic capacity	4.4 litres
Direction of rotation	Clockwise view from front
Firing order	1,3,4,2
Total weight (engine only)	
-dry	463 kg
-wet	485 kg

### Overall dimensions

-height	951 mm (37.44 in)
-length	1241 mm (48.85 in)
-width (including mounting brackets)	629 mm (24.76 in)

### Moment of inertia (mk<sup>2</sup>)

Engine:	
- longitudinal	34,5 kgm <sup>2</sup>
- horizontal	48,8 kgm <sup>2</sup>
- axial	25,1 kgm <sup>2</sup>
Flywheel (polar)	1,14 kgm <sup>2</sup>

### Centre of gravity (wet)

- forward from rear of block	270 mm (10.62 in)
- above centre line of block	151 mm (5.94 in)
- offset of RHS of centre line	13 mm (0.51 in)

### Performance

Steady state speed stability at constant load:

G2  $\pm 0.75\%$

G3  $\pm 0.5\%$

**Note:** All data based on operation to ISO 3046/1, BS 5514 and DIN 6271 standard reference conditions.

### Test conditions

Air temperature  $25\text{ }^{\circ}\text{C}$

Barometric pressure 100 kPa

Relative humidity 30%

### Sound level

Overall sound pressure level (cooling pack and air cleaner fitted):

- at 1500 rev/min 89,7 dBA

- at 1800 rev/min 92,0 dBA

Sound pressure level from the mean of 4 microphones at the front, left, right and above the engine. Exhaust was piped away out of the test cell.

If the engine is to operate in ambient conditions other than those of the test conditions, suitable adjustments must be made for these changes. For full details, contact Perkins Technical Service Department.

## General installation

Designation	Units	Type of Operation and Application			
		Prime	Stand-by	Prime	Stand-by
		50 Hz	50 Hz	60 Hz	60 Hz
Gross engine power	kWm	73,4	80,7	89,5	93,0
Brake mean effective pressure	kPa (lbf/in <sup>2</sup> )	1335 (193.6)	1467 (212.7)	1280 (185.6)	1409 (204.3)
Mean piston speed	m/s (ft/s)	6,35 (20.8)	6,35 (20.8)	7,62 (25.0)	7,62 (25.0)
ElectropaK net engine power	kWm	71,9	79,1	82,0	90,2
Engine coolant flow 35 kPa restriction	l/min (UK gal/min)	142 (31.2)	142 (31.2)	170 (37.3)	170 (37.3)
Combustion air flow	m <sup>3</sup> /min (ft <sup>3</sup> /min)	4,8 (169.5)	5,14 (181.5)	6,2 (218.9)	6,5 (229.5)
Exhaust gas flow (max)	m <sup>3</sup> /min (ft <sup>3</sup> /min)	12,5 (441.4)	13,3 (469.6)	15,0 (529.7)	15,85 (559.7)
Exhaust gas temperature (max) in manifold	°C (°F)	555 (1031)	580 (1076)	535 (995)	560 (1040)
Cooling fan air flow	m <sup>3</sup> /min (ft <sup>3</sup> /min)	89,0 (3143.0)	89,0 (3143.0)	111,0 (3919.9)	111,0 (3919.9)
Overall thermal efficiency	%	39,5	39,5	38,5	39,5
Typical genset electrical unit (0.8 pf 25° C)	kWe	64,0	70,4	73,0	80,3
	kVA	80,0	88,0	91,3	100,3
Assumed alternator efficiency	%	89%			
<b>Energy balance</b>					
Power in fuel (Fuel heat of combustion)	kW (Btu/min)	186,0 (10587.0)	204,0 (11611.6)	220,0 (12522.3)	236,0 (13433.0)
Power output (gross)	kW (Btu/min)	73,4 (4177.9)	80,7 (4593.4)	84,5 (4809.7)	93,0 (5293.5)
Power to cooling fan	kW (Btu/min)	1,5 (85.3)	1,6 (91.0)	2,5 (142.2)	2,8 (159.3)
Power output (net)	kW (Btu/min)	71,9 (4092.5)	79,1 (4502.3)	82,0 (4667.4)	90,2 (5134.1)
Power to coolant and lubricating oil	kW (Btu/min)	46,0 (2618.3)	51,0 (2902.9)	53,0 (3016.7)	57,0 (3244.4)
Power to exhaust	kW (Btu/min)	53,0 (3016.7)	59,0 (3358.2)	68,0 (3870.5)	71,0 (4041.2)
Power to radiation	kW (Btu/min)	13,0 (739.9)	14,0 (796.8)	14,0 (796.8)	15,0 (853.7)

**Caution:** The airflows shown in this table will provide acceptable cooling for an open power unit operating in ambient temperatures of up to 53 °C (127 °F) or 46 °C (114.8 °F) if a canopy is fitted. If the power unit is to be enclosed totally, a cooling test should be done to check that the engine cooling is acceptable. If there is insufficient cooling, contact Perkins Technical Service Department.

## Cooling system

### Radiator

- face area ..... 0.276 m<sup>2</sup> (2.97 ft<sup>2</sup>)
- rows and materials..... double row aluminium
- matrix density and material..... Aluminium 12,5 fins/inch
- width of matrix..... 526 mm (20.7 in)
- height of matrix..... 524 mm (20.6 in)
- pressure cap setting ..... 107 kPa

### Fan

- diameter..... 457,0 mm (18 in)
- drive ratio ..... 1,25 : 1
- number of blades ..... 7
- material..... Composite
- type..... Pusher

### Coolant

- Total system capacity
- with radiator ..... 13,0 l (27.4 pt)
  - without radiator ..... 7,0 l (14.7 pt)
- Maximum top tank temperature ..... 110 °C (230 °F)
- Thermostat operating range..... 82 - 93 °C (180 - 199 °F)
- Recommended coolant: 50 % ethylene glycol with a corrosion inhibitor (BS 658 : 1992 or MOD AL39) and 50% clean fresh water.

## Electrical system

- Type.....Negative ground
- Alternator voltage..... 12 V
- Alternator output ..... 65 amps
- Starter motor voltage..... 12 V
- Starter motor power..... 3 kW
- Number of teeth on flywheel..... 126
- Pull in current of starter motor solenoid ..... 60 amps
- Hold in current of starter motor solenoid..... 15 amps
- Engine stop solenoid..... 12 V
- Stop solenoid (minimum)
- pull in current ..... 10 amps
  - hold in current..... 10 amps

### Cold start recommendations

- Minimum cranking speed..... 105 rev/min

### Starter specification

Starter motor type	Minimum starting temperature	Lubricating oil viscosity SAE / battery type - values in CCA			
		15W/40	10W/40	5W/40	5W/30
12 volt 3.0 kW	°C (°F)	15W/40	10W/40	5W/40	5W/30
	-10 (14)	1 x 810			
	-15 (5) *		1 x 810		
	-20 (-4) *			1 x 810	
	-25 (-13) *				1 x 900

\* - Glow plug start aid fitted.

CCA - Cold Cracking Amps to SAEJ537.

### Notes:

- Battery capacity is defined by the 20 hour rate
- If a change to a low viscosity oil is made, the cranking torque necessary at lower ambient temperatures is much reduced. The starting equipment has been selected to take advantage of this. It is important to change the appropriate multigrade oil in anticipation of operating in low ambient temperatures.
- Breakaway current is dependent on battery capacity available. Cables should be capable of handling the transient current which may be up to double the steady cranking current.

## Exhaust system

- Maximum back pressure
- 1500 rev/min ..... 10 kPa
  - 1800 rev/min ..... 15 kPa
- Exhaust outlet size ..... 64 mm (2.5 in)

## Fuel System

- Type of injection ..... Direct
- Fuel injection pump ..... Rotary
- Fuel atomiser..... Multi-hole
- Nozzel opening pressure ..... 29,0 MPa (290 bar)

### Fuel lift pump

- Type ..... Electrical
- flow/hour ..... 120 - 150 l/h (211 - 264 pt/m)
- pressure ..... 30 - 75 kPa (4.4 - 10.9 psi)
- Maximum suction head ..... 17 kPa (2.46 psi)

### Governor type

- Electronic governor ..... Woodward LCS2
- Electronic governor speed control to..... ISO 8528 , G3 (Hot)
- Mechanical governor speed control to ..... ISO 8528, G2 (Cold)

### Fuel specification

Fuel Specification	European RF75-T-96 / DIN EN590 / BS2869 class A2
Density (kg/l @ 15 °C)	0,835 - 0,845
Viscosity (mm <sup>2</sup> /s @ 40 °C)	2,5 - 3,5
Sulphur content (%)	0,1 - 0,2
Cetane number	45 - 50

### Fuel consumption litres/hour (UK gals/hr)

Speed	Power rating				
	110%	100%	75%	50%	25%
1500	20,5 (4.5)	18,7 (4.1)	14,0 (3.0)	9,7 (2.1)	5,2 (1.1)
1800	24,4 (5.3)	22,3 (4.9)	16,9 (3.7)	11,9 (2.6)	6,5 (1.4)

## Induction system

### Maximum air intake restriction

- clean filter..... 5,0 kPa
- dirty filter..... 8,0 kPa
- air filter type..... Dry

## Lubrication system

### Lubricating oil capacity

- Total system.....8,0 l (16.9 pt)
- Sump minimum .....5,5 l (11.6 pt)
- Sump maximum ..... 7,0 l (14.7 pt)

Maximum engine operating angles:

- front up, front down, right side or left side ..... 25°

### Lubricating oil pressure

- relief valve opens ..... 415 - 470 kPa
  - at maximum no-load speed..... 276 - 414 kPa
- Max continuous oil temperature ..... 125 °C (257 °F)
- Oil consumption at full load as a % of fuel consumption ..... 0.15%

1104A-44TG2 ElectropaK - left view

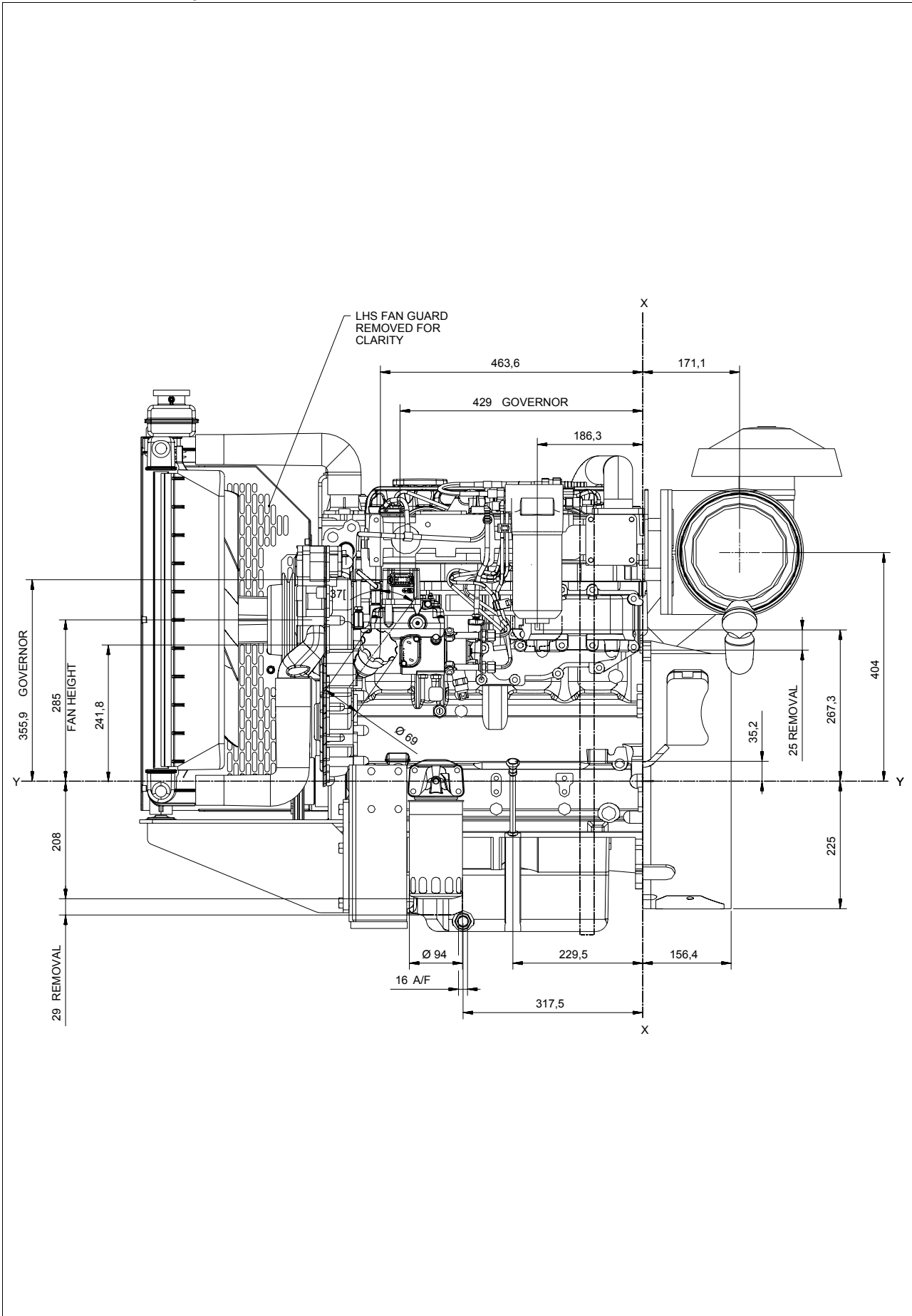

# 1104A-44TG2 Electropak - front view

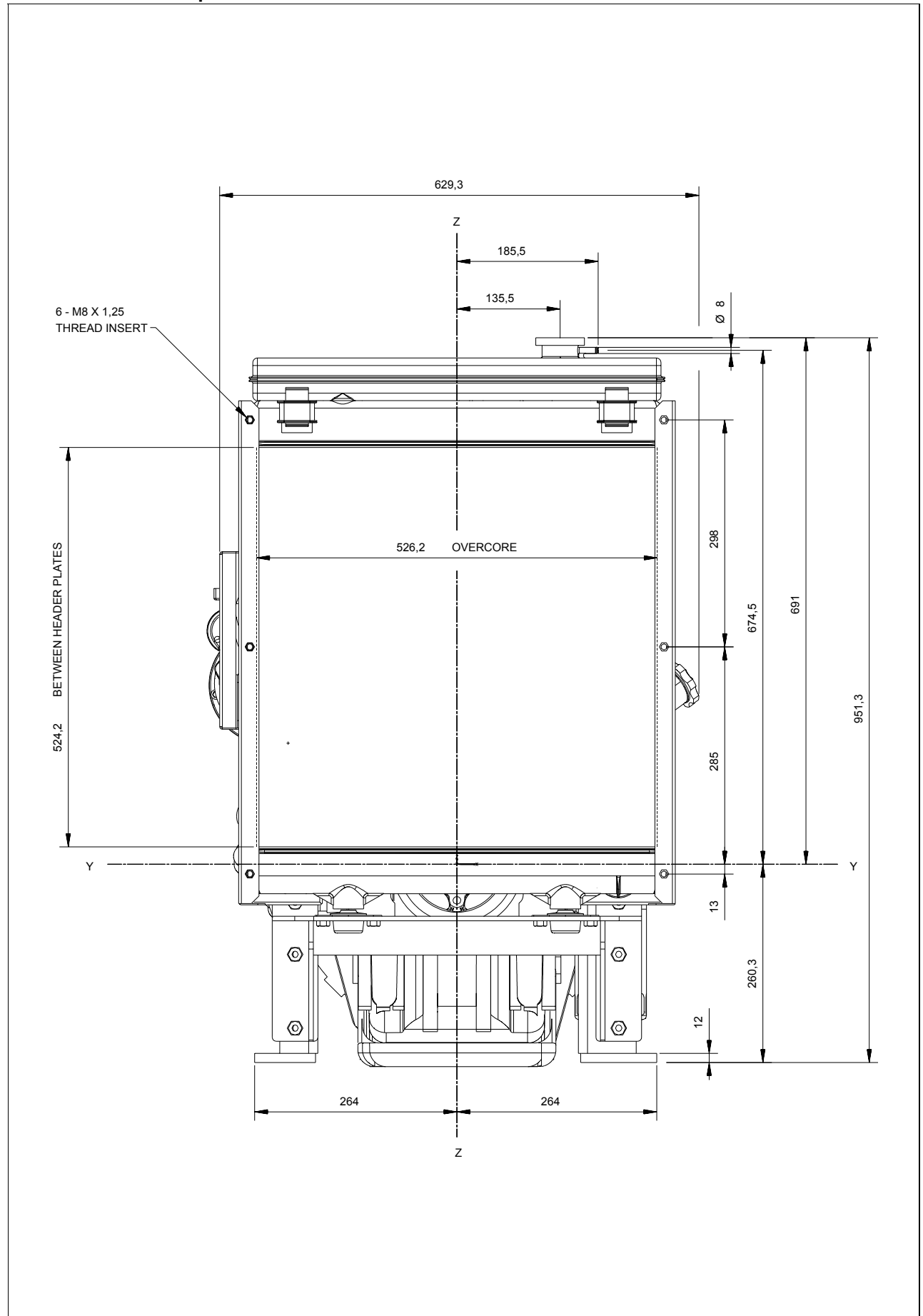

1104A-44TG2 ElectropaK - right view

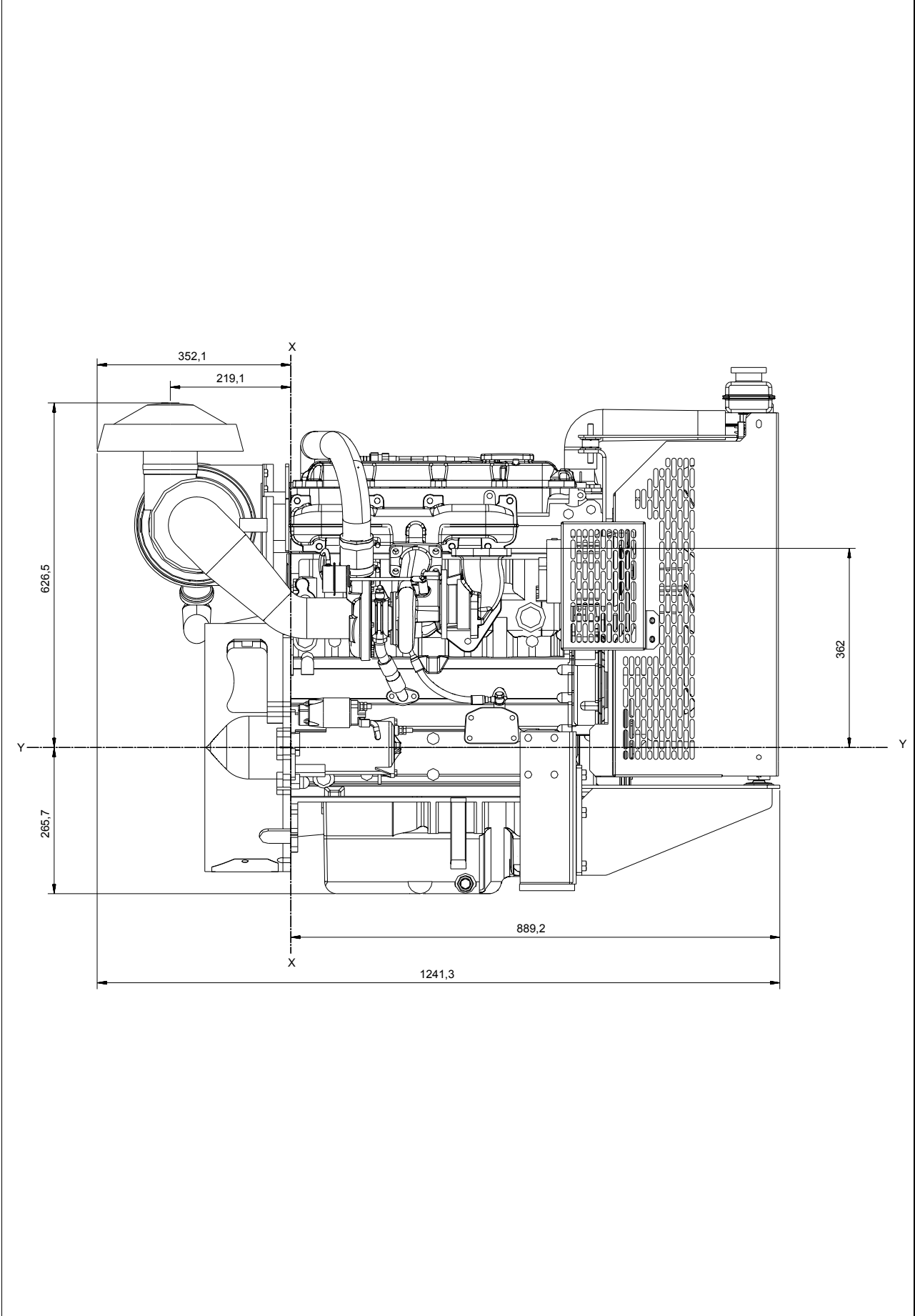

# 1104A-44TG2 Electropak - rear view

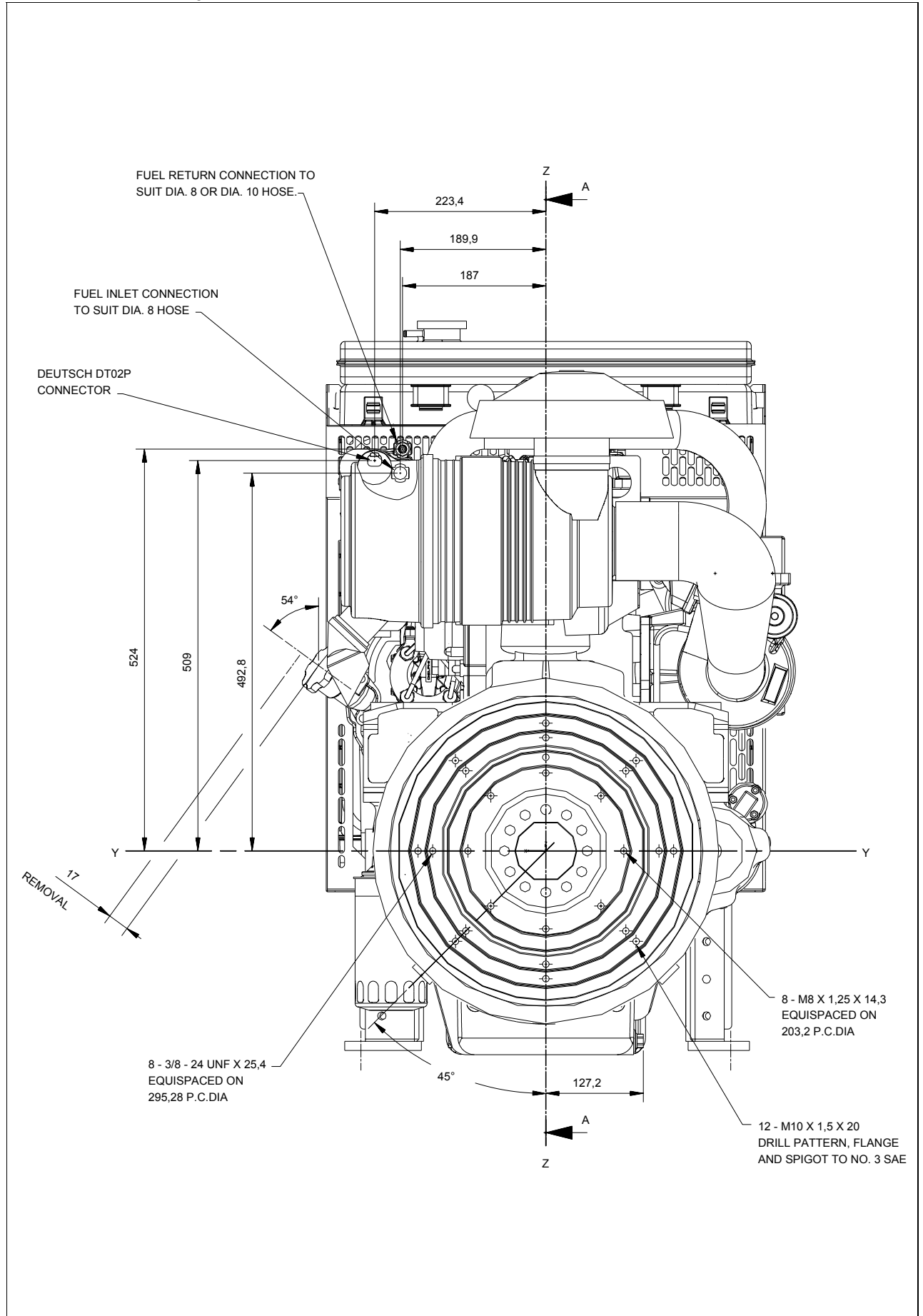

**Recommended SAE viscosity**

A single or multigrade oil must be used which conforms to API-CG4 / CH4, see illustration below:

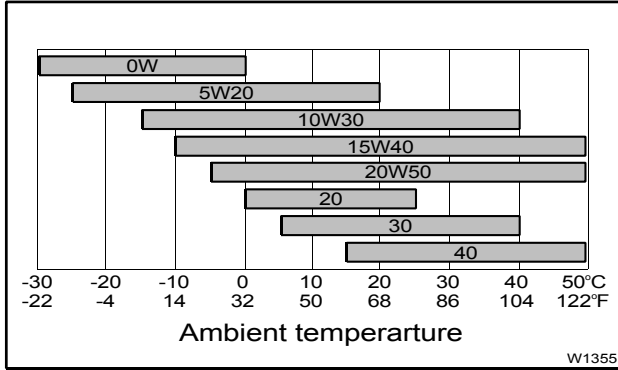

**Mountings**

Maximum static bending moment at rear face of block ... 791 Nm (583 lb/ft)

**Load Acceptance**

Initial load application when engine reaches rated speed (15 seconds max after engine starts to crank)			
	Units	1500 rev/min	1800 rev/min
Prime Power	%	90	100
Load	kW (kWe)	66,1 (57.5)	84,2 (72.4)
Transient frequency deviation	%	<-10%	<-10%
Frequency recovery	seconds	< 1	< 1

The above complies with requirements of classification 3 & 4 of ISO 8528-12 and G2 operating limits stated in ISO 8528-5. The above figures were obtained under the test conditions as follows:

Engine block temperature ... 45 °C  
 Alternator ... 96%  
 Maximum ambient temperature ... 10%

**Isochronous governing:**

- typical alternator inertia ... 50 kgm<sup>2</sup>

All tests were conducted using an engine which was installed and serviced to Perkins Engines Company Limited recommendations.

**The information given in this document is for guidance only.**

**@ Perkins®**

**Perkins Engines Company Limited**  
 Peterborough PE1 5NA United Kingdom  
 Telephone +44 (0) 1733 583000  
 Fax +44 (0) 1733 582240  
 www.perkins.com

All information in the document is substantially correct at the time of printing but may be subsequently altered by the company.

Distributed by

**UCI224G** - Technical Data Sheet

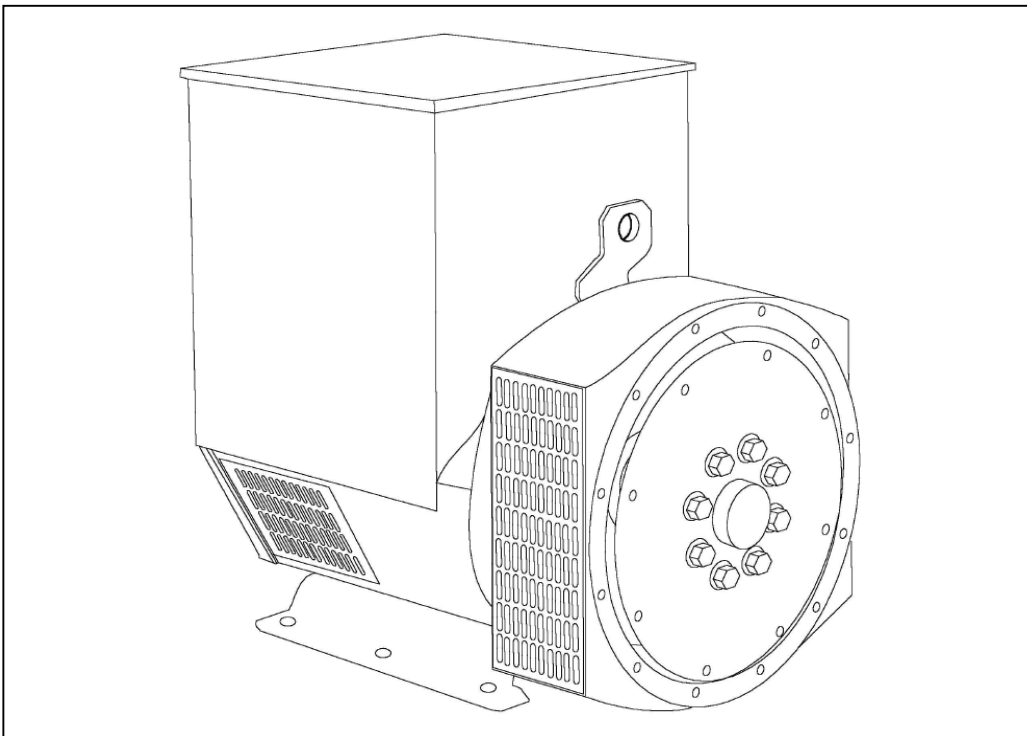

# UCI224G

## SPECIFICATIONS & OPTIONS



### STANDARDS

Newage Stamford industrial generators meet the requirements of BS EN 60034 and the relevant section of other international standards such as BS5000, VDE 0530, NEMA MG1-32, IEC34, CSA C22.2-100, AS1359. Other standards and certifications can be considered on request.

### VOLTAGE REGULATORS

#### SX460 AVR - STANDARD

With this self excited control system the main stator supplies power via the Automatic Voltage Regulator (AVR) to the exciter stator. The high efficiency semiconductors of the AVR ensure positive build-up from initial low levels of residual voltage.

The exciter rotor output is fed to the main rotor through a three phase full wave bridge rectifier. This rectifier is protected by a surge suppressor against surges caused, for example, by short circuit.

#### SX440 AVR

With this self-excited system the main stator provides power via the AVR to the exciter stator. The high efficiency semi-conductors of the AVR ensure positive build-up from initial low levels of residual voltage.

The exciter rotor output is fed to the main rotor through a three-phase full-wave bridge rectifier. The rectifier is protected by a surge suppressor against surges caused, for example, by short circuit or out-of-phase paralleling.

The SX440 will support a range of electronic accessories, including a 'droop' Current Transformer (CT) to permit parallel operation with other ac generators.

If 3-phase sensing is required with the self-excited system, the SX421 AVR must be used.

#### SX421AVR

This AVR also operates in a self-excited system. It combines all the features of the SX440 with, additionally, three-phase rms sensing for improved regulation and performance. Over voltage protection is provided via a separate circuit breaker. An engine relief load acceptance feature is built in as standard.

#### MX341 AVR

This sophisticated AVR is incorporated into the Stamford Permanent Magnet Generator (PMG) control system.

The PMG provides power via the AVR to the main exciter, giving a source of constant excitation power independent of generator output. The main exciter output is then fed to the main rotor, through a full wave bridge, protected by a surge suppressor. The AVR has in-built protection against sustained over-excitation, caused by internal or external faults. This de-excites the machine after a minimum of 5 seconds.

An engine relief load acceptance feature can enable full load to be applied to the generator in a single step.

If three-phase sensing is required with the PMG system the MX321 AVR must be used.

We recommend three-phase sensing for applications with greatly unbalanced or highly non-linear loads.

#### MX321 AVR

The most sophisticated of all our AVRs combines all the features of the MX341 with, additionally, three-phase rms sensing, for improved regulation and performance. Over voltage protection is built-in and short circuit current level adjustments is an optional facility.

### WINDINGS & ELECTRICAL PERFORMANCE

All generator stators are wound to 2/3 pitch. This eliminates triplen (3rd, 9th, 15th ...) harmonics on the voltage waveform and is found to be the optimum design for trouble-free supply of non-linear loads. The 2/3 pitch design avoids excessive neutral currents sometimes seen with higher winding pitches, when in parallel with the mains. A fully connected damper winding reduces oscillations during paralleling. This winding, with the 2/3 pitch and carefully selected pole and tooth designs, ensures very low waveform distortion.

### TERMINALS & TERMINAL BOX

Standard generators are 3-phase reconnectable with 12 ends brought out to the terminals, which are mounted on a cover at the non-drive end of the generator. A sheet steel terminal box contains the AVR and provides ample space for the customers' wiring and gland arrangements. It has removable panels for easy access.

### SHAFT & KEYS

All generator rotors are dynamically balanced to better than BS6861:Part 1 Grade 2.5 for minimum vibration in operation. Two bearing generators are balanced with a half key.

### INSULATION/IMPREGNATION

The insulation system is class 'H'.

All wound components are impregnated with materials and processes designed specifically to provide the high build required for static windings and the high mechanical strength required for rotating components.

### QUALITY ASSURANCE

Generators are manufactured using production procedures having a quality assurance level to BS EN ISO 9001.

The stated voltage regulation may not be maintained in the presence of certain radio transmitted signals. Any change in performance will fall within the limits of Criteria 'B' of EN 61000-6-2:2001. At no time will the steady-state voltage regulation exceed 2%.

*NB Continuous development of our products entitles us to change specification details without notice, therefore they must not be regarded as binding.*

*Front cover drawing typical of product range.*

## UCI224G WINDING 311

CONTROL SYSTEM		SEPARATELY EXCITED BY P.M.G.							
A.V.R.		MX321	MX341						
VOLTAGE REGULATION		± 0.5 %	± 1.0 %	With 4% ENGINE GOVERNING					
SUSTAINED SHORT CIRCUIT		REFER TO SHORT CIRCUIT DECREMENT CURVES (page 7)							
CONTROL SYSTEM		SELF EXCITED							
A.V.R.		SX460	SX440	SX421					
VOLTAGE REGULATION		± 1.5 %	± 1.0 %	± 0.5 %	With 4% ENGINE GOVERNING				
SUSTAINED SHORT CIRCUIT		SERIES 4 CONTROL DOES NOT SUSTAIN A SHORT CIRCUIT CURRENT							
INSULATION SYSTEM		CLASS H							
PROTECTION		IP23							
RATED POWER FACTOR		0.8							
STATOR WINDING		DOUBLE LAYER CONCENTRIC							
WINDING PITCH		TWO THIRDS							
WINDING LEADS		12							
STATOR WDG. RESISTANCE		0.055 Ohms PER PHASE AT 22°C SERIES STAR CONNECTED							
ROTOR WDG. RESISTANCE		0.94 Ohms at 22°C							
R.F.I. SUPPRESSION		BS EN 61000-6-2 & BS EN 61000-6-4,VDE 0875G, VDE 0875N. refer to factory for others							
WAVEFORM DISTORTION		NO LOAD < 1.5% NON-DISTORTING BALANCED LINEAR LOAD < 5.0%							
MAXIMUM OVERSPEED		2250 Rev/Min							
BEARING DRIVE END		BALL. 6312-2RS (ISO)							
BEARING NON-DRIVE END		BALL. 6309-2RS (ISO)							
		1 BEARING				2 BEARING			
WEIGHT COMP. GENERATOR		383 kg				400 kg			
WEIGHT WOUND STATOR		139 kg				139 kg			
WEIGHT WOUND ROTOR		126.75 kg				118.38 kg			
WR <sup>2</sup> INERTIA		0.7136 kgm <sup>2</sup>				0.6818 kgm <sup>2</sup>			
SHIPPING WEIGHTS in a crate		404 kg				420 kg			
PACKING CRATE SIZE		105 x 57 x 96(cm)				105 x 57 x 96(cm)			
		50 Hz				60 Hz			
TELEPHONE INTERFERENCE		THF<2%				TIF<50			
COOLING AIR		0.216 m <sup>3</sup> /sec 458 cfm				0.281 m <sup>3</sup> /sec 595 cfm			
VOLTAGE SERIES STAR		380/220	400/231	415/240	440/254	416/240	440/254	460/266	480/277
VOLTAGE PARALLEL STAR		190/110	200/115	208/120	220/127	208/120	220/127	230/133	240/138
VOLTAGE SERIES DELTA		220/110	230/115	240/120	254/127	240/120	254/127	266/133	277/138
KVA BASE RATING FOR REACTANCE VALUES		85	85	85	79	93.8	97.5	100	103.8
Xd DIR. AXIS SYNCHRONOUS		2.43	2.20	2.04	1.69	2.66	2.47	2.32	2.21
X'd DIR. AXIS TRANSIENT		0.19	0.17	0.16	0.13	0.20	0.19	0.17	0.17
X''d DIR. AXIS SUBTRANSIENT		0.13	0.12	0.11	0.09	0.14	0.13	0.12	0.12
Xq QUAD. AXIS REACTANCE		1.12	1.01	0.94	0.78	1.22	1.13	1.06	1.01
X''q QUAD. AXIS SUBTRANSIENT		0.17	0.15	0.14	0.12	0.15	0.14	0.13	0.12
X <sub>L</sub> LEAKAGE REACTANCE		0.07	0.06	0.06	0.05	0.08	0.07	0.07	0.07
X <sub>2</sub> NEGATIVE SEQUENCE		0.16	0.14	0.13	0.11	0.15	0.14	0.13	0.12
X <sub>0</sub> ZERO SEQUENCE		0.11	0.10	0.09	0.07	0.11	0.10	0.10	0.09
REACTANCES ARE SATURATED VALUES ARE PER UNIT AT RATING AND VOLTAGE INDICATED									
T'd TRANSIENT TIME CONST.		0.03 s							
T''d SUB-TRANSTIME CONST.		0.008 s							
T'do O.C. FIELD TIME CONST.		0.75 s							
T <sub>a</sub> ARMATURE TIME CONST.		0.007 s							
SHORT CIRCUIT RATIO		1/Xd							

**50  
Hz**

**UCI224G**  
Winding 311



**THREE PHASE EFFICIENCY CURVES**

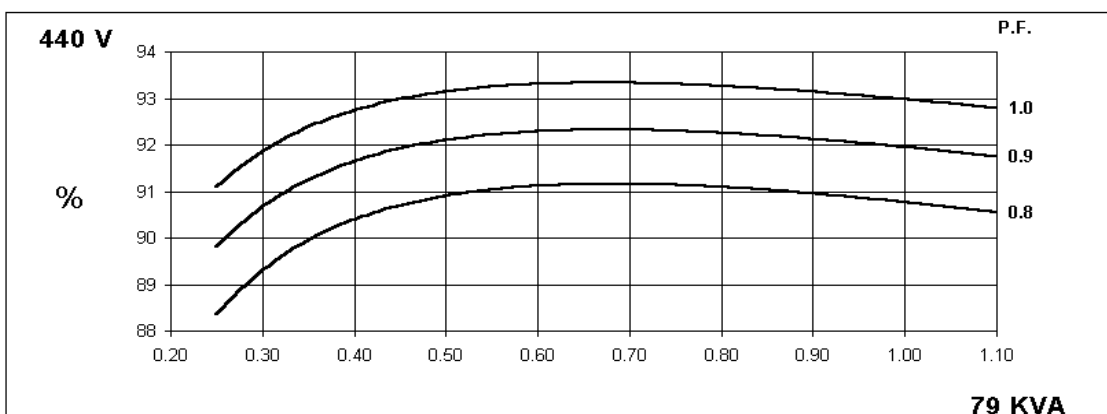
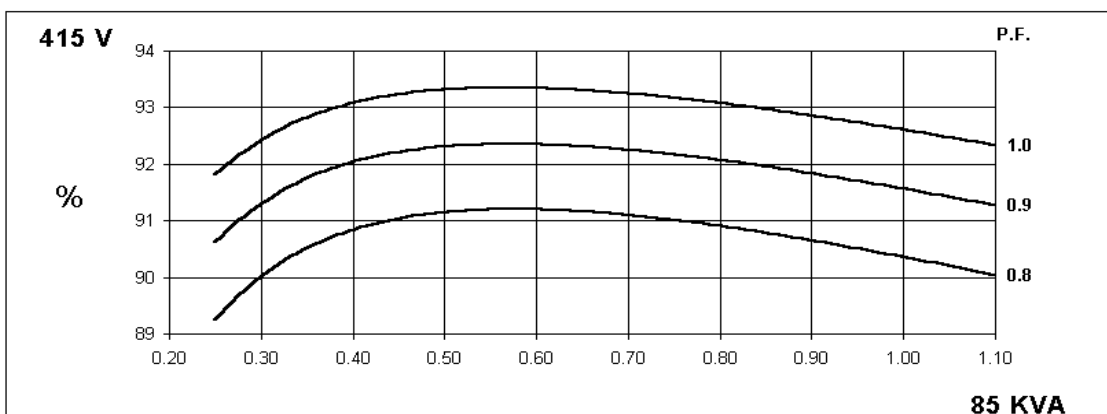
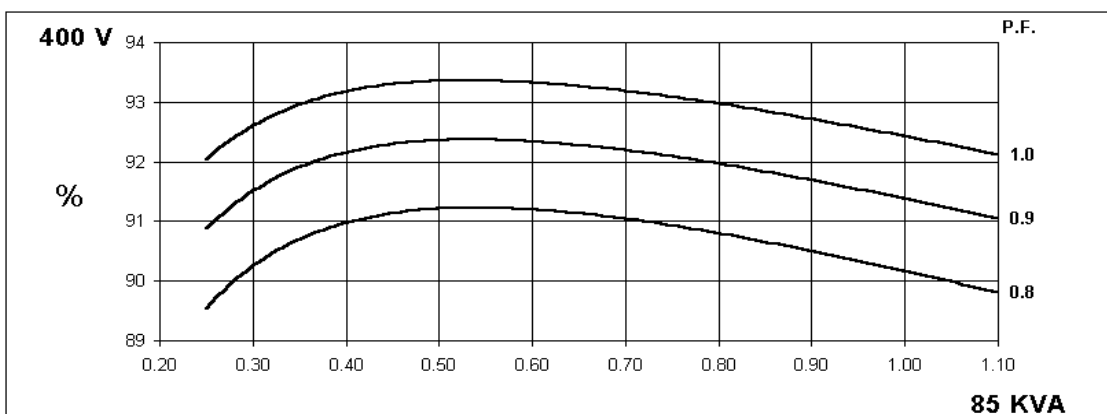
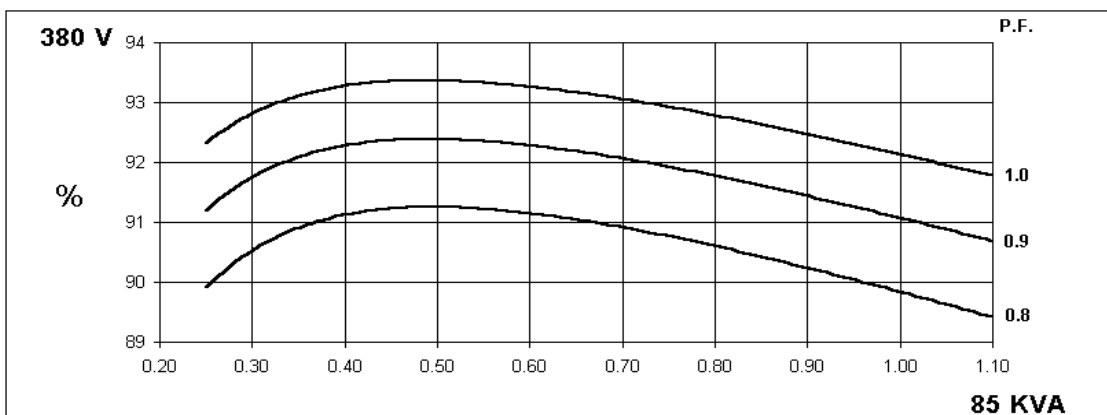

**THREE PHASE EFFICIENCY CURVES**

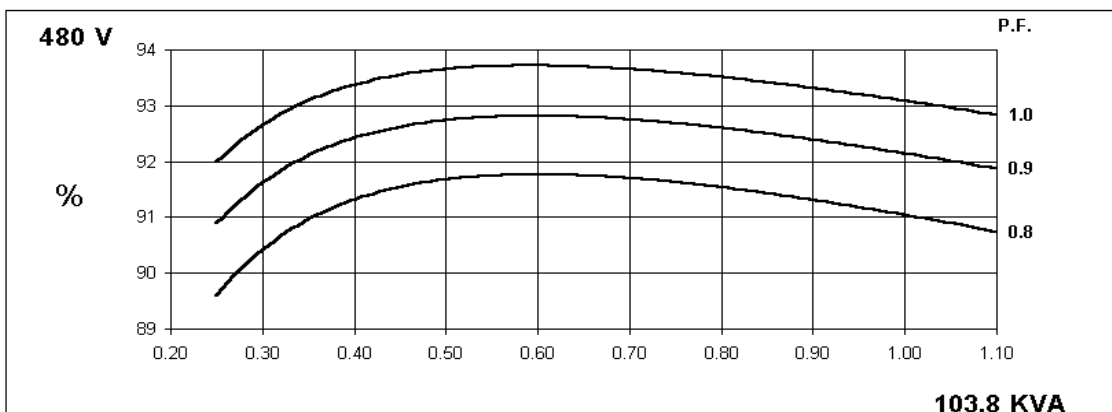
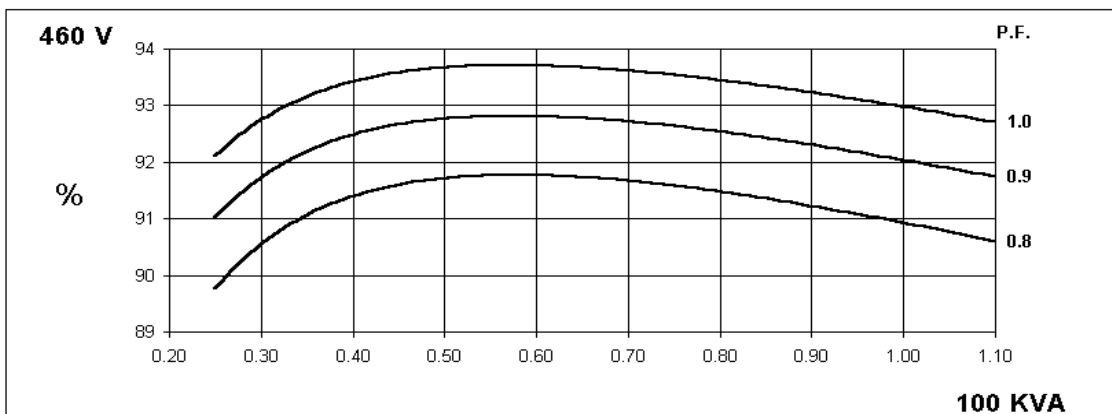
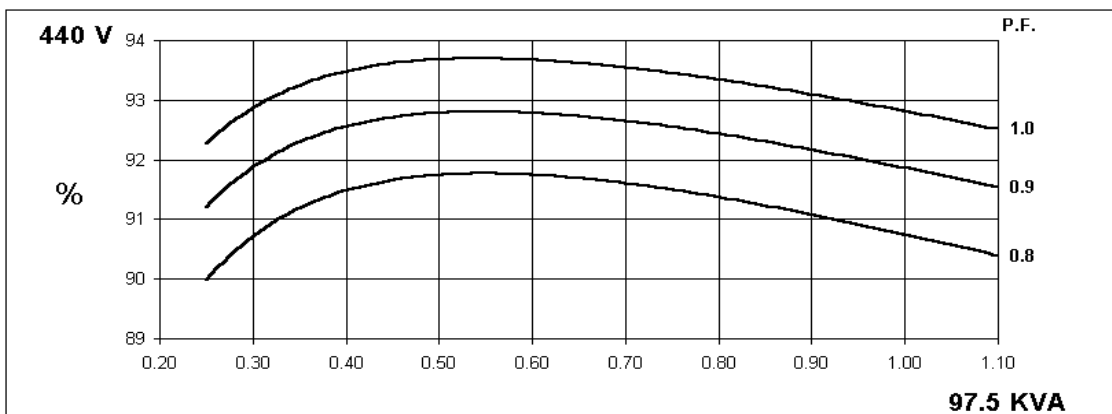
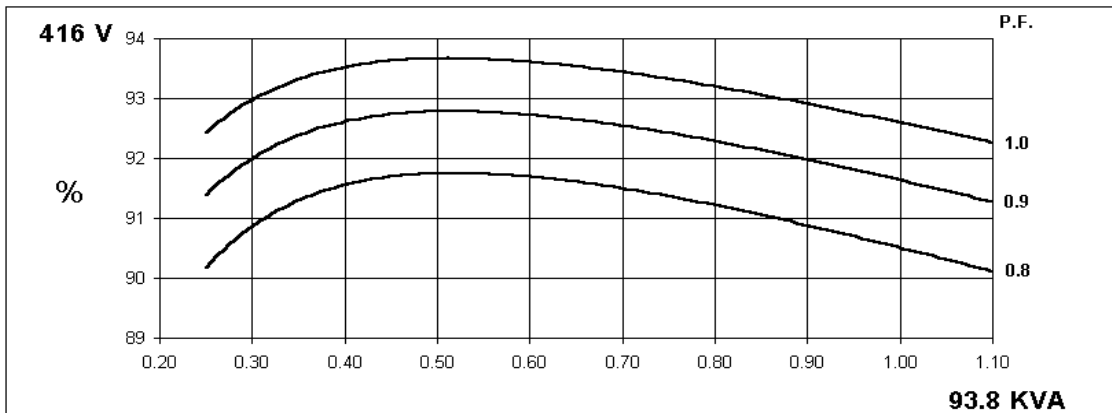

# UCI224G

## Winding 311



### Locked Rotor Motor Starting Curve

**50  
Hz**

**MX**

**SX**

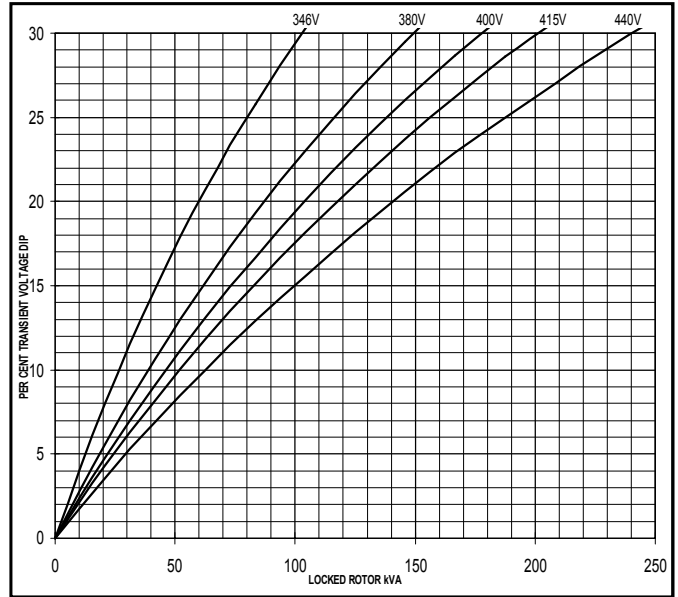
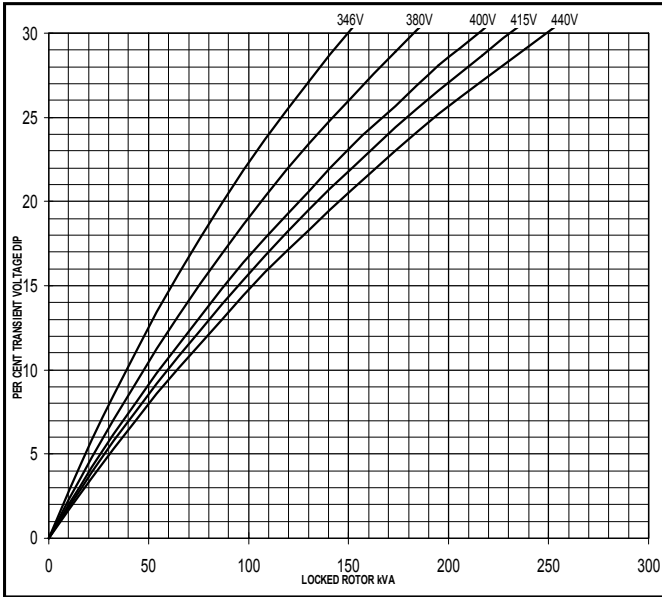

**60  
Hz**

**MX**

**SX**

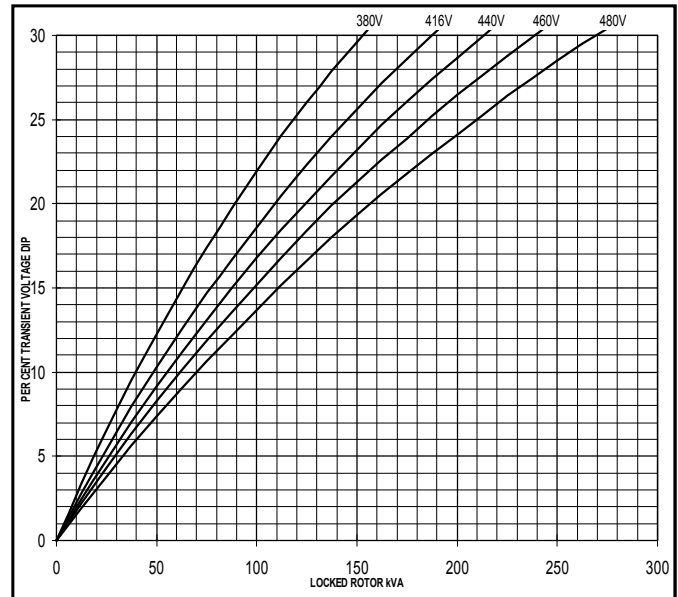
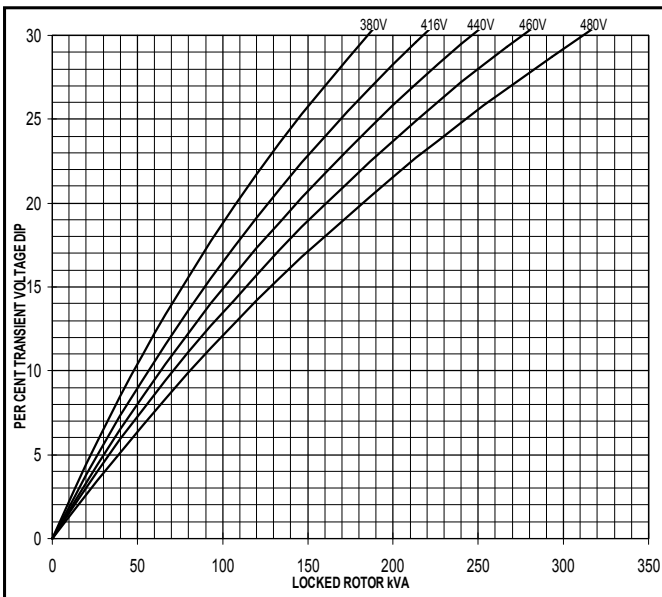

**Three-phase Short Circuit Decrement Curve. No-load Excitation at Rated Speed  
Based on star (wye) connection.**

**50  
Hz**

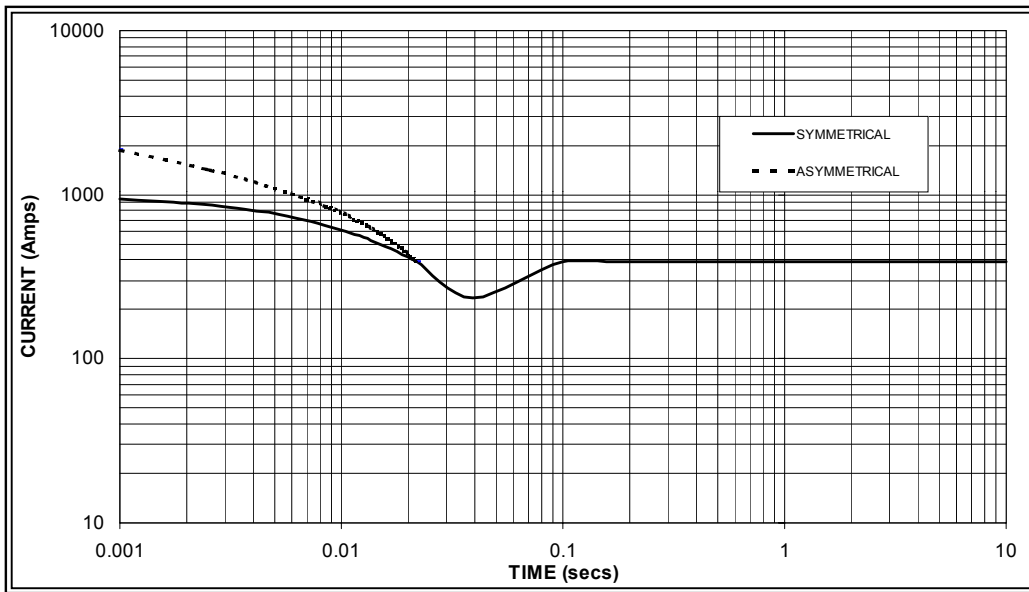

Sustained Short Circuit = 390 Amps

**60  
Hz**

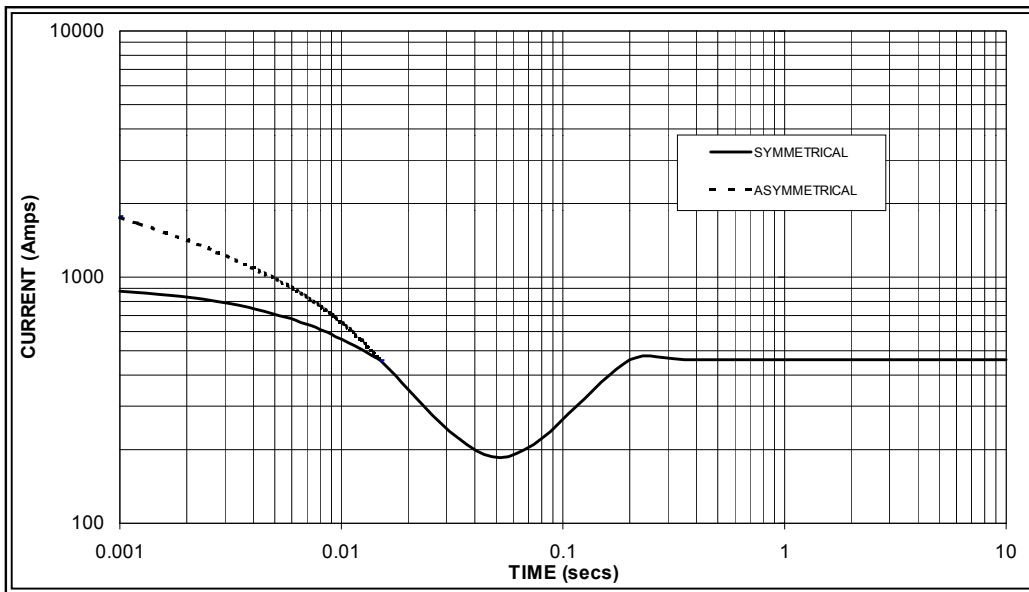

Sustained Short Circuit = 460 Amps

**Note 1**

The following multiplication factors should be used to adjust the values from curve between time 0.001 seconds and the minimum current point in respect of nominal operating voltage :

50Hz		60Hz	
Voltage	Factor	Voltage	Factor
380v	X 1.00	416v	X 1.00
400v	X 1.07	440v	X 1.06
415v	X 1.12	460v	X 1.12
440v	X 1.18	480v	X 1.17

The sustained current value is constant irrespective of voltage level

**Note 2**

The following multiplication factor should be used to convert the values calculated in accordance with NOTE 1 to those applicable to the various types of short circuit :

	3-phase	2-phase L-L	1-phase L-N
Instantaneous	x 1.00	x 0.87	x 1.30
Minimum	x 1.00	x 1.80	x 3.20
Sustained	x 1.00	x 1.50	x 2.50
Max. sustained duration	10 sec.	5 sec.	2 sec.

All other times are unchanged

**Note 3**

Curves are drawn for Star (Wye) connected machines. For other connection the following multipliers should be applied to current values as shown :

Parallel Star = Curve current value X 2

Series Delta = Curve current value X 1.732

# UCI224G

## Winding 311 / 0.8 Power Factor



### RATINGS

Class - Temp Rise	Cont. F - 105/40°C				Cont. H - 125/40°C				Standby - 150/40°C				Standby - 163/27°C				
<b>50 Hz</b>	Series Star (V)	380	400	415	440	380	400	415	440	380	400	415	440	380	400	415	440
	Parallel Star (V)	190	200	208	220	190	200	208	220	190	200	208	220	190	200	208	220
	Series Delta (V)	220	230	240	254	220	230	240	254	220	230	240	254	220	230	240	254
kVA	75.0	75.0	75.0	67.4	85.0	85.0	85.0	75.0	87.5	87.5	87.5	76.9	90.8	90.8	90.8	80.1	
kW	60.0	60.0	60.0	53.9	68.0	68.0	68.0	60.0	70.0	70.0	70.0	61.5	72.6	72.6	72.6	64.1	
Efficiency (%)	90.3	90.6	90.7	91.0	89.8	90.2	90.4	90.8	89.7	90.1	90.3	90.7	89.6	89.9	90.1	90.6	
kW Input	66.4	66.2	66.2	62.4	75.7	75.4	75.2	69.6	78.0	77.7	77.5	71.4	81.1	80.8	80.6	74.5	

<b>60 Hz</b>	Series Star (V)	416	440	460	480	416	440	460	480	416	440	460	480	416	440	460	480
	Parallel Star (V)	208	220	230	240	208	220	230	240	208	220	230	240	208	220	230	240
	Delta (V)	240	254	266	277	240	254	266	277	240	254	266	277	240	254	266	277
kVA	87.5	90.0	93.8	95.0	93.8	97.5	100.0	103.8	98.1	102.5	102.5	110.0	101.3	106.3	106.3	113.8	
kW	70.0	72.0	75.0	76.0	75.0	78.0	80.0	83.0	78.5	82.0	82.0	88.0	81.0	85.0	85.0	91.0	
Efficiency (%)	90.8	91.0	91.1	91.3	90.5	90.8	90.9	91.0	90.3	90.6	90.9	90.9	90.2	90.4	90.7	90.8	
kW Input	77.1	79.1	82.4	83.2	82.9	85.9	88.0	91.3	86.9	90.5	90.2	96.8	89.8	94.1	93.8	100.3	

### DIMENSIONS

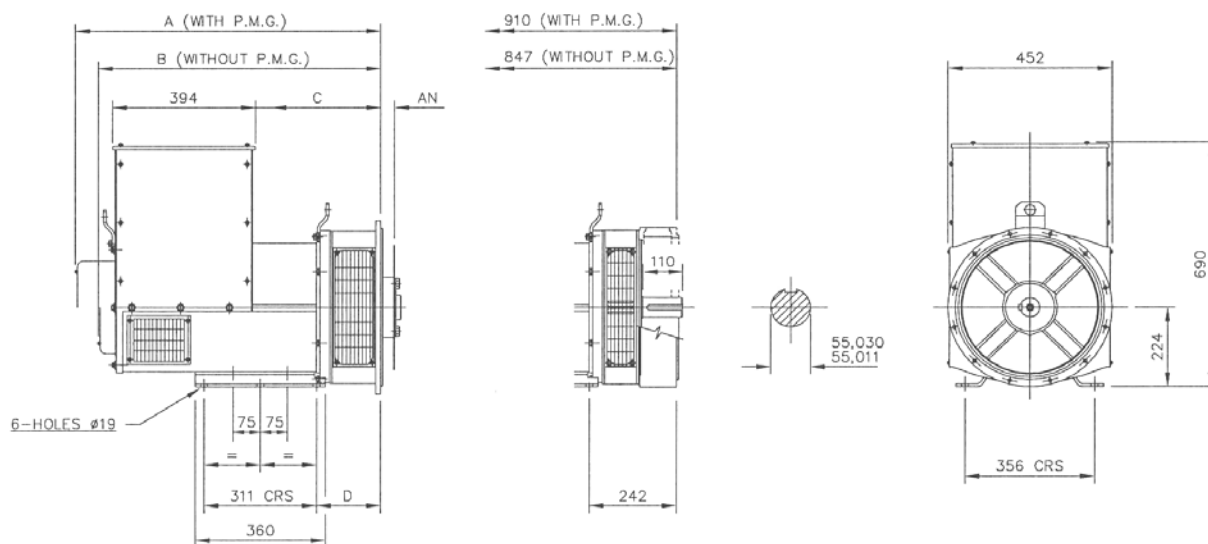

SINGLE BEARING ADAPTORS				
ADAPTOR	A	B	C	D
SAE 1	859,3	796,3	359,3	191,3
SAE 2	845	782	345	177
SAE 3	845	782	345	177
SAE 4	845	782	345	177

COUPLING DISCS	
DISC	AN
SAE 8	61,90
SAE 10	53,98
SAE 11,5	39,68
SAE 14	25,40



PO Box 17 • Barnack Road • Stamford • Lincolnshire • PE9 2NB

Tel: 00 44 (0)1780 484000 • Fax: 00 44 (0)1780 484100

Website: [www.newage-avkseg.com](http://www.newage-avkseg.com)