



ottomotores

PERKINS SERIE E14

Energía que Mueve al Mundo

Definiciones

Potencia Prime

Estos valores son aplicables para el suministro de energía eléctrica continua (a carga variable) en lugar de la red comercial.

Potencia Stand by

Estos valores son aplicables para el suministro de energía eléctrica continua (a carga variable) en caso de falla de la red comercial. No se permite sobrecarga sobre estos valores.

Tabla de Potencias

Modelo	Voltaje	Prime kVA	Prime kW	Stand-by kVA	Stand-by kW
PNY350	220-440V	400	320	438	350
PNY400	220-440V	438	350	500	400

0.8 Factor de potencia

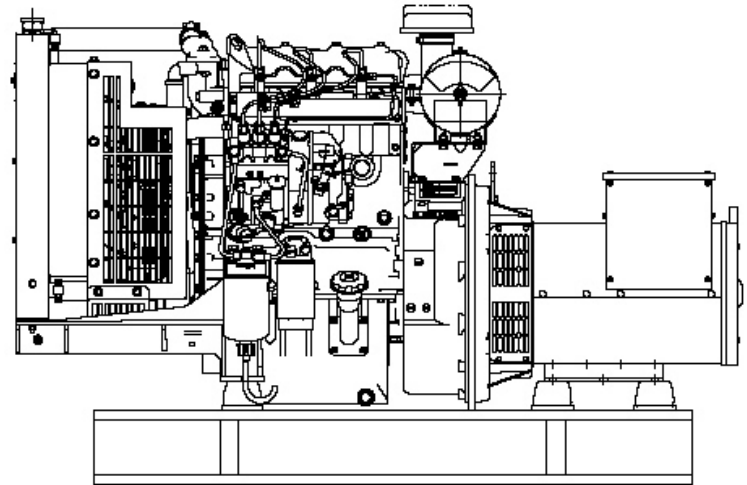

Información Técnica

Datos Técnicos	PNY350	PNY400
Frecuencia:	60 Hz	60 Hz
Motor Marca / Modelo	Perkins E14TAG2	Perkins E14TAG3
Generador Marca/Modelo:	Stamford HCI434E	Stamford HCI434F
Numero de polos del Generador:	4 polos	4 polos
Tipo de aislamiento del Generador:	Tipo H	Tipo H
Número de Cilindros del motor:	12	12
Diametro por Carrera : (mm)	5.91 x 6.30 (150 x 160)	5.91 x 6.89(150 x 175)
Relación de Compresión:	15.3:1	14.5:1
Aspiración:	Turbo/Enfriado por aire	Turbo/Enfriado por aire
Velocidad:	1800 RPM	1800 RPM
Potencia del motor: kWm	1207(900)	1528(1140)
Presion Efectiva: Lbf/in ² (kPa)		297(20.9)
Velocidad de Piston: ft/s (m/s)	1890(9.6)	2067(10.5)
Consumo de combustible : lt / hr - 100%	235.2	240
Calor Expulsado en el Sistema de Escape : BTU/min (kW)	304	55416(837876)
Calor Expulsado en el Sistema de Enfriamiento: BTU/min (kW)	146	163
Temperatura de Escape: °F (°C)	3913(59166)	453
Flujo de Enfriamiento en el Radiador m ³ /min	1380(48728)	530
Flujo de Escape:m ³ /min (ft ³ /min)	7450(211)	91
Dimensiones (Largo x Ancho x Alto)cm	345x111x182	345x111x182
Peso Aprox. humedo kg.	3011	3147

Los equipos en foto pudieran incluir accesorios opcionales

Como leer nuestro codigo: Ejem: PNY30

P=Motor Perkins
 N=Generador Newage Stamford
 E=50Hz-1500 RPM
 Y=60Hz-1800 RPM
 30= Potencia del Equipo.



Energía que Mueve al Mundo



Ottomotores, S.A de C.V.

Calz. San Lorenzo No.1150
 Col. Cerro de la estrella, C.P. 09860
 Delg. Iztapalapa México, D.F.
 Tels:52-55-5624-5600

Fax: 52-55-5426-5521 / 52-55-5426-5581

ventas@ottomotores.com.mx

www.ottomotores.com.mx



MODELS
PNE 450
PNY 400

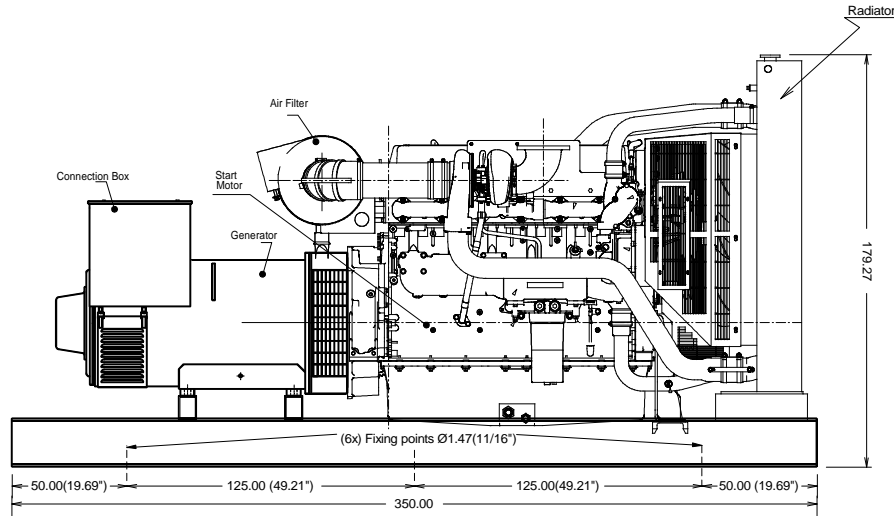

SIDE VIEW

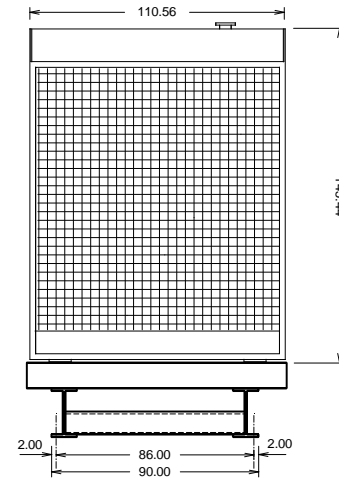

FRONT VIEW

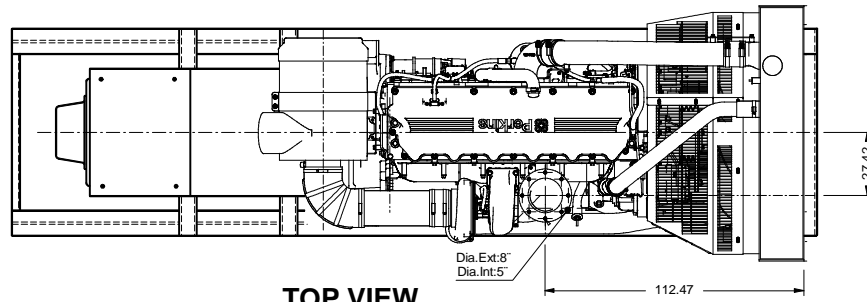

TOP VIEW

DESCRIPTION	
RADIATOR:	IS INCLUDED
ENGINE:	E-141A G3
GENERATOR:	HC1534C
AIR FILTER:	AH1135
BASE FRAME:	BPRK-04
TOTAL WEIGHT:	DRY-2586.35 Kgs. WET-2694.85 Kgs.
	AVMS SPRING 4 PZS

-THE GENSET DIMENSIONS ARE THE SAME BY FAMILY MODEL, THERE COULD BE ONLY DIFFERENCES ON THE ALTERNATOR LENGHT SEE SPECIFIC GENERAL ARRANGEMENT DRAWING OF CERTAIN MODEL
 -TOTAL WEIGHT COULD VARY CHECK RATING CHART FOR EACH MODEL

Customer:	S/O:	Title: GENERAL ARRANGEMENT PERKINS ENGINE E14TAG3 STAMFORD ALTERNATOR	
		Draw: E.A.C.	Revised: R.G.C.
		Date: JUL 21th 2008	Date: JUL 21th 2008
		Certificated: JNG. V.F.F.	Code: PNE/Y-04
			Dept.: Engineering
			Marks: cms
			Scale: s/e
			Draw: N/A
			Of: N/A
Rev.	Description	Date	Certificated
Reviews			



Ottomores keeps the right to change the information with out prior notice



2300 Series

2306C-E14TAG3

Diesel Engine – Electropak

387 kWm at 1500 rpm
430 kWm at 1800 rpm

Economic Power

- Mechanically operated unit fuel injectors with advanced electronic control, combined with carefully matched turbocharging, give excellent fuel atomisation which leads to exceptional low fuel consumption.

Reliable Power

- Developed and tested using the latest engineering techniques and finite element analysis for high reliability.
- Low oil usage and low wear rates.
- High compression ratio ensures clean rapid starting in all conditions.
- Support comes from a worldwide network of 4,000 distributors and dealers.

Compact, Clean and Efficient Power

- Exceptional power to weight ratio and compact size gives optimum power density for ease of installation and more cost effective transportation.
- Designed to provide excellent service access for ease of maintenance.
- 2306C-E14TAG engines are capable of meeting TA Luft (2002).

Certified against the requirements of EU 2007 (EU 97/68/EC Stage II) legislation for non-road mobile machinery, powered by constant speed engines.



The Perkins 2300 Series is a family of well-proven 6 cylinder in-line diesel engines, designed to address today's uncompromising demands within the power generation industry with particular aim at the standby market sector. Developed from a proven heavy-duty industrial base, the engine offers superior performance and reliability.

The 2306C-E14TAG3 is a turbocharged and air-to-air charge-cooled 6-cylinder diesel engine. Its premium features provide economic and durable operation for standby duty, low gaseous emissions, overall performance and reliability.

Engine Speed (rev/min)	Type of Operation	Typical Generator Output (Net)		Engine Power			
		kVA	kWe	Gross		Net	
				kWm	bhp	kWm	bhp
1500	Baseload Power	300	240	270	362	261	350
	Prime Power	400	320	353	473	344	461
	Standby Power	450	360	396	531	387	519
1800	Baseload Power	344	275	316	424	299	401
	Prime Power	438	350	394	528	377	505
	Standby Power	500	400	447	600	430	577

The above ratings represent the engine performance capabilities to conditions specified in ISO 8528/1, ISO 3046/1:1986, BS 5514/1. Derating may be required for conditions outside these; consult Perkins Engines Company Limited.

Generator powers are typical and are based on an average alternator efficiency and a power factor (cos. θ) of 0.8.

Fuel specification: BS 2869: Part 2 1998 Class A2 or ASTM D975 D2.

Lubricating oil: 15W40 to API CG4.

Rating Definitions

Baseload Power: Power available for continuous full load operation. Overload of 10% permitted for 1 hour in every 12 hours operation

Prime Power: Power available at variable load with a load factor not exceeding 80% of the prime power rating. Overload of 10% is permitted for 1 hour in every 12 hours operation

Standby Power: Power available in the event of a main power network failure up to a maximum of 500 hours per year of which up to 300 hours may be run continuously. Load factor may be up to 100% of standby power. No overload is permitted.

2300 Series

2306C-E14TAG3

Standard ElectropaK Specification

Air inlet

- Mounted air filter

Fuel system

- Mechanically actuated electronically controlled unit fuel injectors with full authority electronic control.
- Governing to ISO 8528-5 class G3 with isochronous capability
- Replaceable 'ecoplus' fuel filter elements with primary filter/water separator
- Fuel cooler

Lubrication system

- Wet sump with filler and dipstick
- Full-flow replaceable 'ecoplus' filter
- Oil cooler integral with filter header

Cooling system

- Gear-driven circulating pump
- Mounted belt-driven fan
- Radiator supplied loose incorporating air-to-air charge cooler
- System designed for ambients up to 50°C

Electrical equipment

- 24 volt starter motor and 24 volt 70 amp alternator with DC output
- ECM mounted on engine with wiring looms and sensors
- 3 level engine protection system

Flywheel and housing

- High inertia flywheel to SAE J620 Size 14
- SAE ½ flywheel housing

Mountings

- Front engine mounting bracket

Literature

- User's Handbook and Parts Manual

Optional Equipment

- 110 volt/240 volt immersion heater
- Additional speed sensor
- Temperature and pressure sensors for gauges
- Electric hours counter
- Air filter rain hood
- Twin starters/facility for second starter
- Tool kit
- Additional manuals

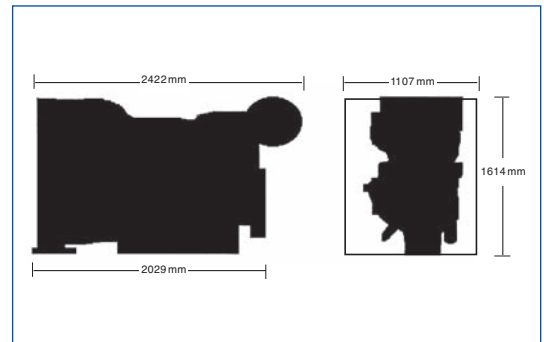

Engine Speed	Fuel Consumption			
	1500 rev/min		1800 rev/min	
	g/kWh	l/hr	g/kWh	l/hr
Standby	213	96	206	103
Prime power	214	85	214	94
Baseload power	213	64	221	77
75% of prime power	214	64	222	73
50% of prime power	227	45	229	50

General Data

Number of cylinders	6
Cylinder arrangement	Vertical in-line
Cycle	4 stroke
Induction system	Turbocharged and air-to-air charge cooled
Combustion system	Direct injection
Cooling system	Water-cooled
Bore and stroke	137 x 165 mm
Displacement	14.6 litres
Compression ratio	15.9:1
Direction of rotation	Anti-clockwise, viewed on flywheel
Total lubrication system capacity	68 litres
Total coolant capacity	47 litres
Total dry weight	1690 kg
Dimensions	Length 2422 mm Width 1107 mm Height 1614 mm

Final weight and dimensions will depend on completed specification
 Fuel consumption figures are for EU 2007 Certified engines.
 For ½ TA Luft compliance please see Perkins' Technical Data Sheet.



Perkins Engines Company Limited

Peterborough PE1 5NA
 United Kingdom
 Telephone +44 (0)1733 583000
 Fax +44 (0)1733 582240
www.perkins.com



Distributed by

FRAME HC434F/444F HCK434F/444F

WINDING 311

RATINGS	REFER TO RATINGS BOOK
OVERLOAD	REFER TO RATINGS BOOK
ALTITUDE	REFER TO RATINGS BOOK
AMBIENT TEMP.	REFER TO RATINGS BOOK

CONTROL SYSTEM SER. 3	SEPARATELY EXCITED BY P.M.G. FRAME DESIGNATION HC434		
A.V.R.	MX341	MX321	
VOLTAGE REGULATION	± 1.0%	± 0.5%	WITH 4% ENGINE GOVERNING
SUSTAINED SHORT CIRCUIT	REFER TO SHORT CIRCUIT DECREMENT CURVES OF THIS SECTION		

CONTROL SYSTEM SER. 4	SELF EXCITED FRAME DESIGNATION HC444		
A.V.R.	SX440	SX421	
VOLTAGE REGULATION	± 1.0%	± 0.5%	WITH 4% ENGINE GOVERNING
SUSTAINED SHORT CIRCUIT	SERIES 4 CONTROL DOES NOT SUSTAIN A SHORT CIRCUIT CURRENT		

INSULATION SYSTEM	CLASS H		
PROTECTION	IP22 STANDARD - IP23 OPTIONAL (5% DERATE)		
RATED POWER FACTOR	0.8		
STATOR WINDING	DOUBLE LAYER LAP		
WINDING PITCH	TWO THIRDS		
WINDING LEADS	12		
STATOR WDG. RESISTANCE	0.010 Ohms PER PHASE AT 22°C SERIES STAR CONNECTED		
ROTOR WDG. RESISTANCE	1.35 Ohms at 22°C		
R.F.I. SUPPRESSION	BS EN 50081/2-1/2 VDE 0875G VDE 0875N For other standards apply to the factory		
WAVEFORM DISTORTION	NO LOAD < 1.5% NON-DISTORTING BALANCED LINEAR LOAD < 5.0%		
MAXIMUM OVERSPEED	2250 Rev/Min		
BEARING DRIVE END HC ONLY	BALL. 6317 (ISO)		
BEARING NON-DRIVE END	BALL. 6314 (ISO)		
EFFICIENCY	REFER TO EFFICIENCY CURVES OF THIS SECTION		
	1 BEARING	2 BEARING HC ONLY	
WEIGHT COMP. GENERATOR	1170 kg	1160 kg	
WEIGHT WOUND STATOR	535 kg	535 kg	
WEIGHT WOUND ROTOR	473 kg	440 kg	
WR ² INERTIA	5.53 kgm ²	5.22 kgm ²	

	50 Hz				60 Hz			
TELEPHONE INTERFERENCE	THF < 2%				TIF < 50			
COOLING AIR FOR HC	0.486 m ³ /sec 1030 cfm				0.58 m ³ /sec 1240 cfm			
COOLING AIR FOR HCK	0.68 m ³ /sec 1450 cfm				0.83 m ³ /sec 1760 cfm			
VOLTAGE SERIES STAR (Y)	380/220	400/231	415/240	440/254	416/240	440/254	460/266	480/277
VOLTAGE PARALLEL STAR (Y)	190/110	200/115	208/120	220/127	208/120	220/127	230/133	240/138
VOLTAGE EDISON DELTA (Δ)	220/110	230/115	240/120	250/125	240/120	254/127	266/133	277/138
kVA BASE RATING FOR REACTANCE VALUES	380	380	380	380	444	456	463	475
X _d DIR. AXIS SYNCHRONOUS	2.59	2.34	2.17	1.93	3.21	2.95	2.74	2.59
X' _d DIR. AXIS TRANSIENT	0.17	0.16	0.14	0.13	0.18	0.18	0.17	0.16
X'' _d DIR. AXIS SUBTRANSIENT	0.12	0.11	0.10	0.09	0.13	0.12	0.12	0.11
X _q QUAD. AXIS REACTANCE	2.25	2.03	1.87	1.67	2.84	2.60	2.42	2.28
X'' _q QUAD. AXIS SUBTRANSIENT	0.31	0.28	0.25	0.23	0.42	0.38	0.36	0.34
X _L LEAKAGE REACTANCE	0.06	0.05	0.05	0.04	0.07	0.06	0.06	0.06
X ₂ NEGATIVE SEQUENCE	0.22	0.20	0.18	0.17	0.28	0.26	0.24	0.23
X ₀ ZERO SEQUENCE	0.09	0.07	0.07	0.06	0.10	0.08	0.08	0.08
REACTANCES ARE SATURATED				VALUES ARE PER UNIT AT RATING AND VOLTAGE INDICATED				
T' _d TRANSIENT TIME CONST.								0.080 sec
T'' _d SUB-TRANSTIME CONST.								0.019 sec
T' _{do} O.C. FIELD TIME CONST.								1.700 sec
T _a ARMATURE TIME CONST.								0.018 sec
SHORT CIRCUIT RATIO								1/X _d

**SERIES 3 WINDING 311
 LOCKED ROTOR MOTOR STARTING CURVE**

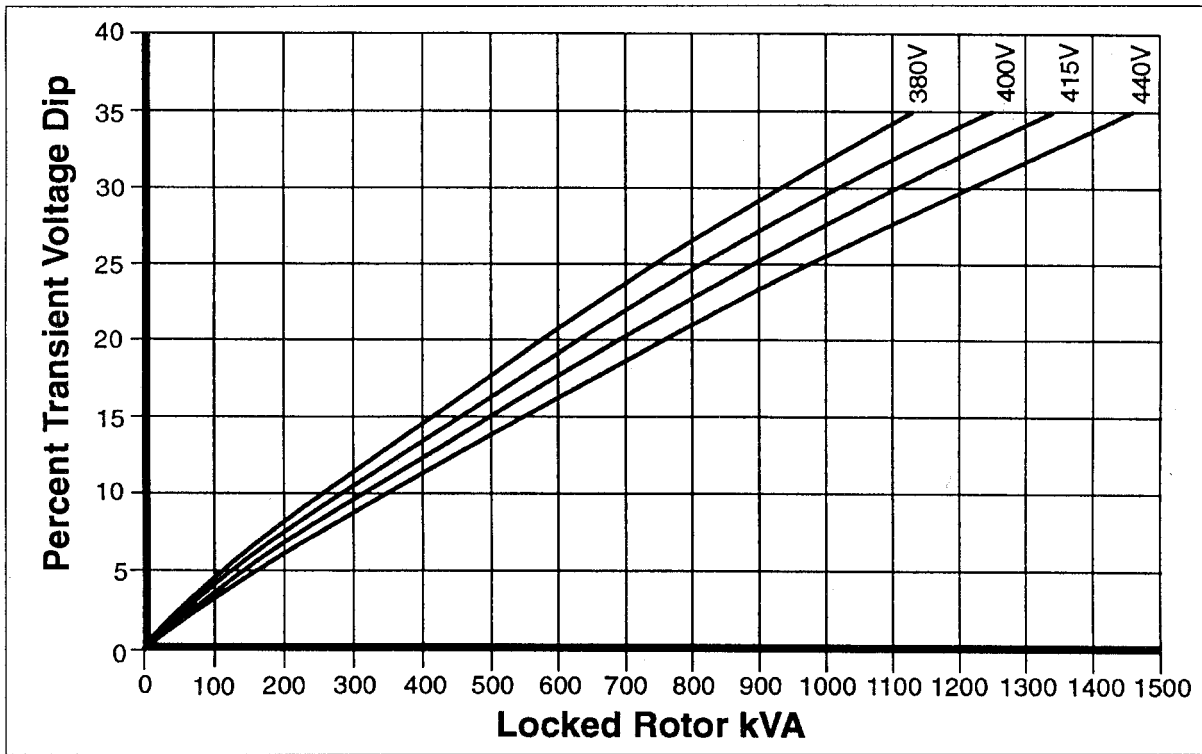

**SERIES 3 WINDING 311
 LOCKED ROTOR MOTOR STARTING CURVE**

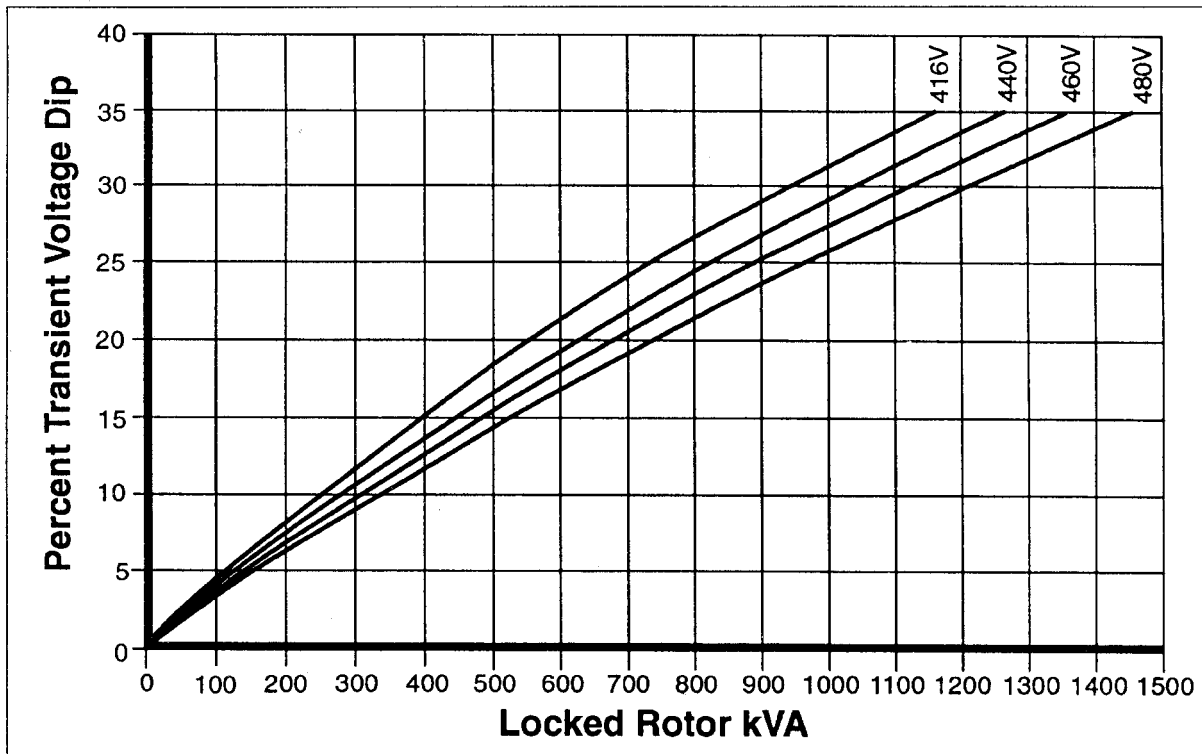

**SERIES 4 WINDING 311
LOCKED ROTOR MOTOR STARTING CURVE**

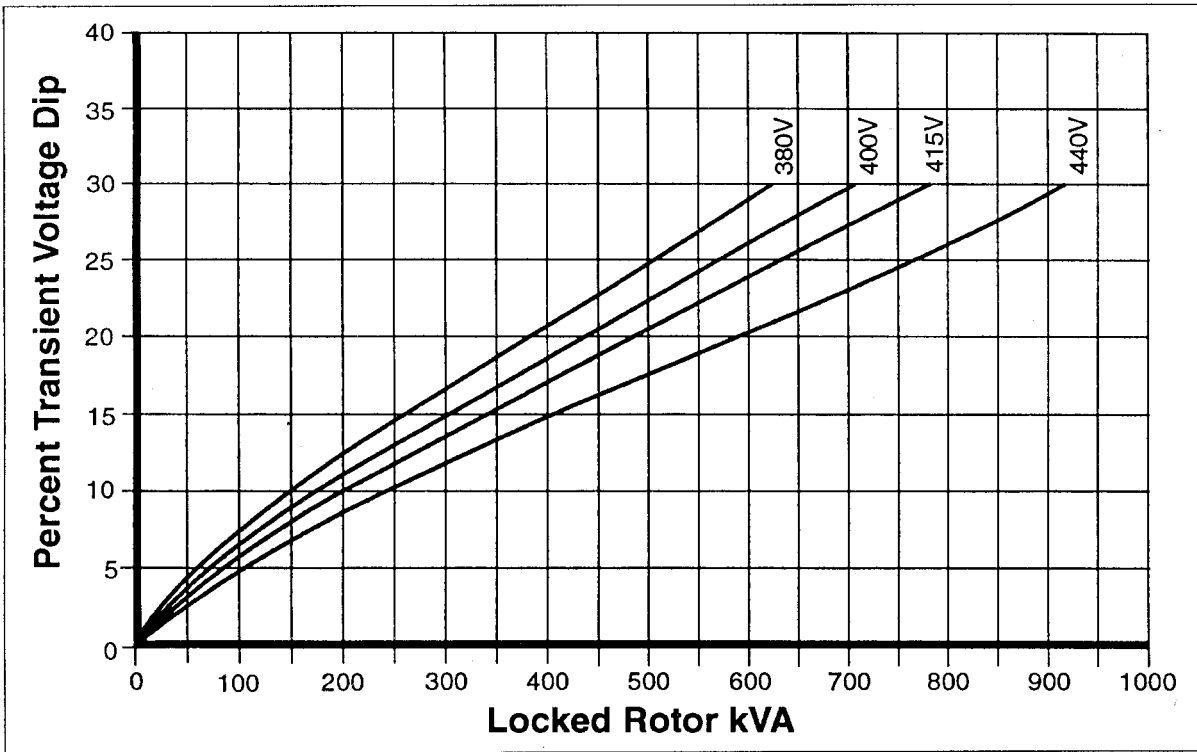

**SERIES 4 WINDING 311
LOCKED ROTOR MOTOR STARTING CURVE**

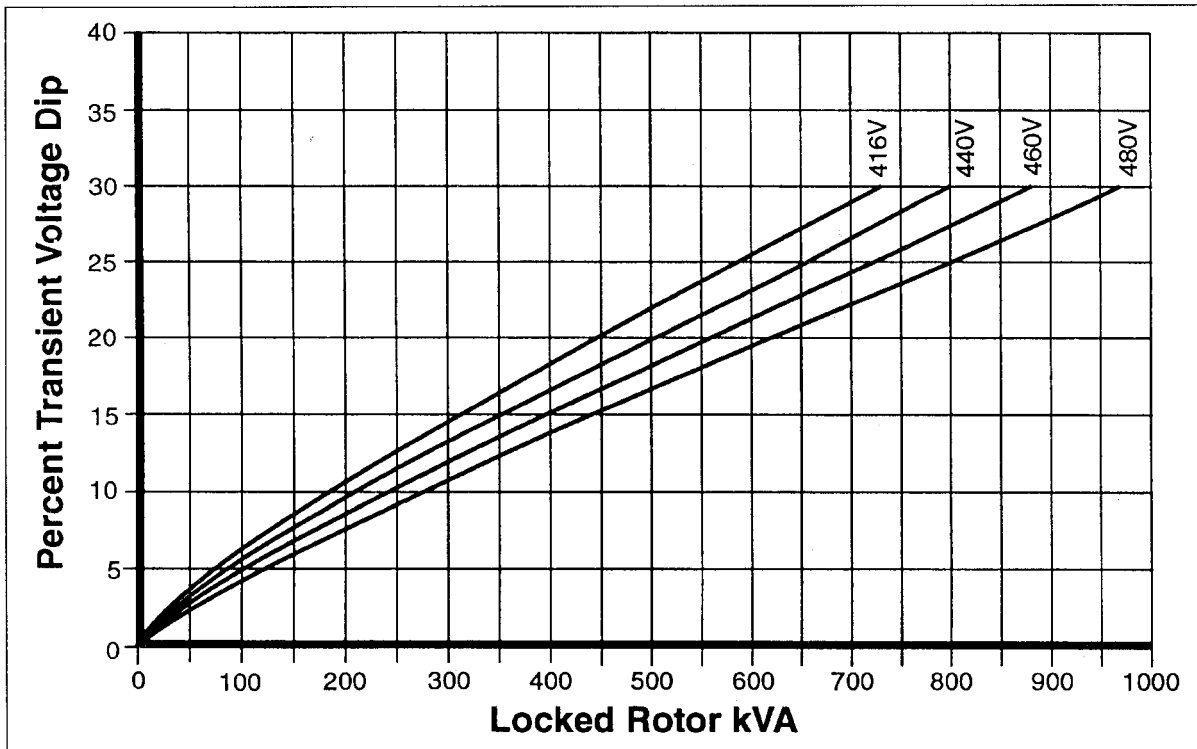

THREE PHASE EFFICIENCY CURVES

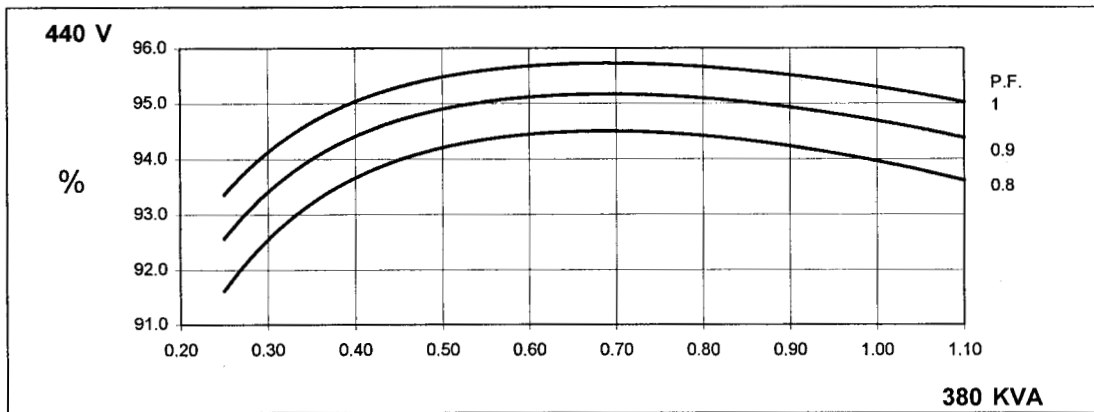
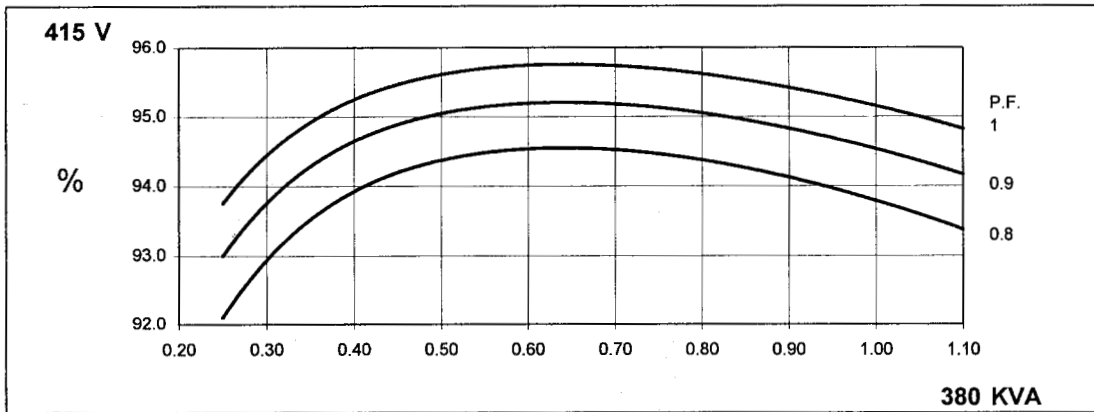
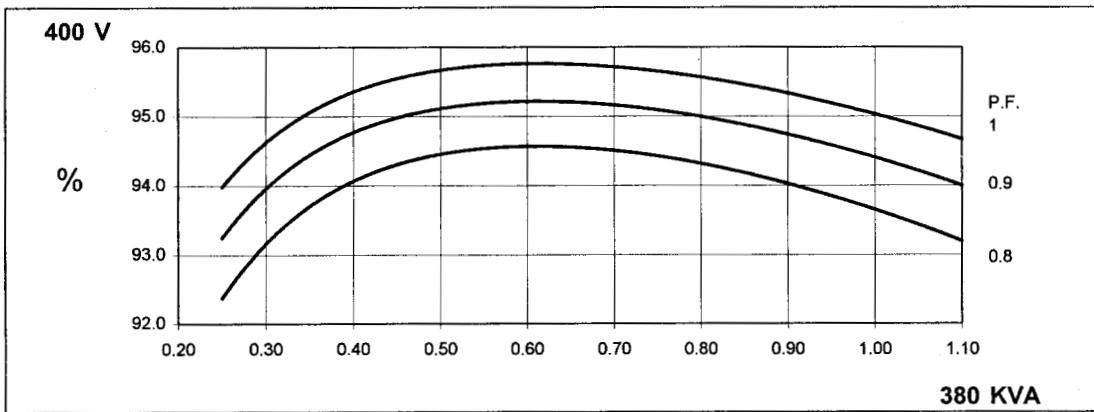
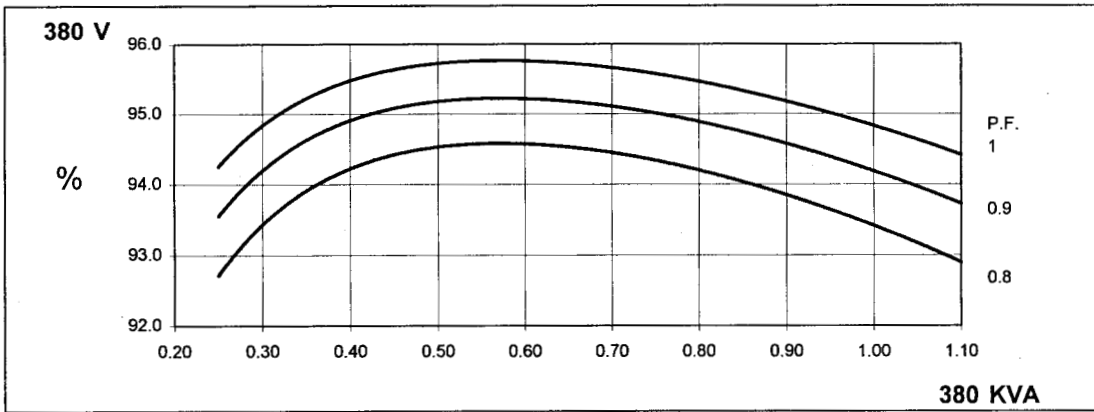

THREE PHASE EFFICIENCY CURVES

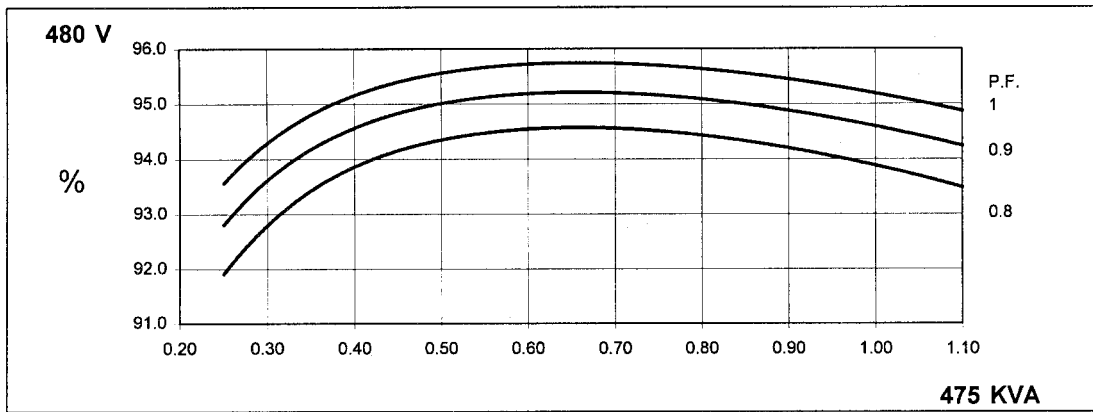
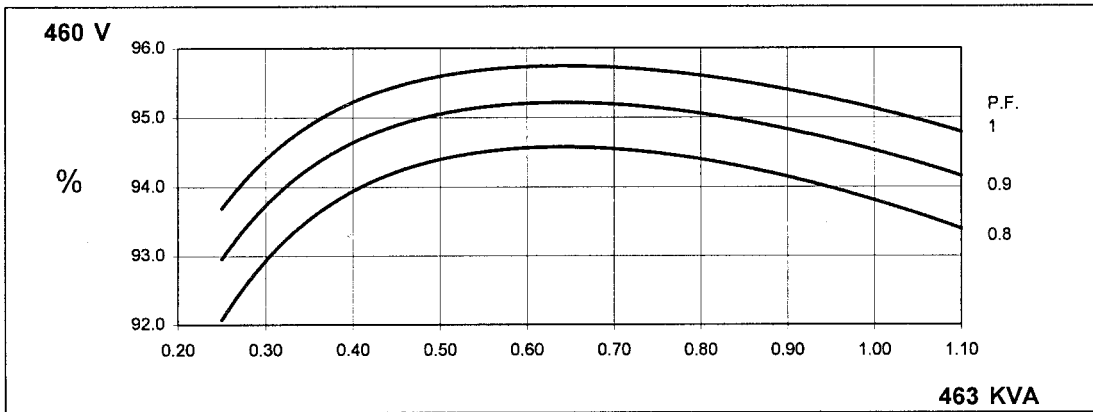
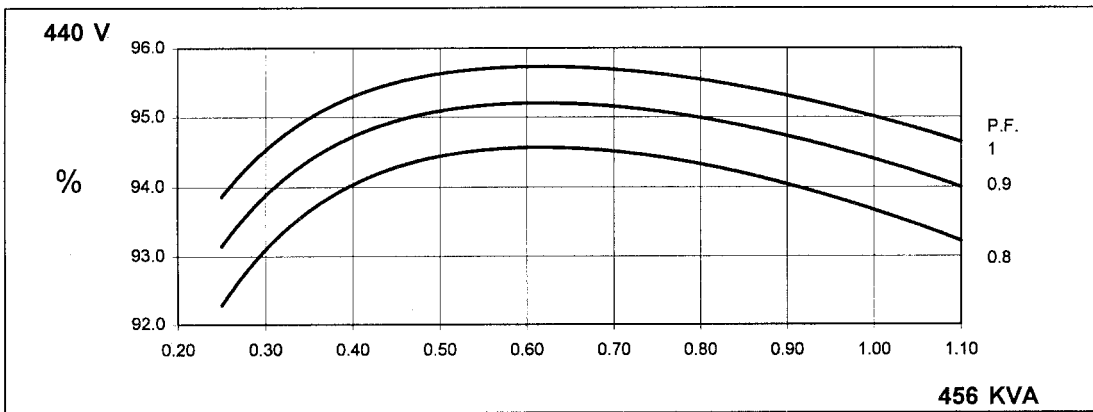
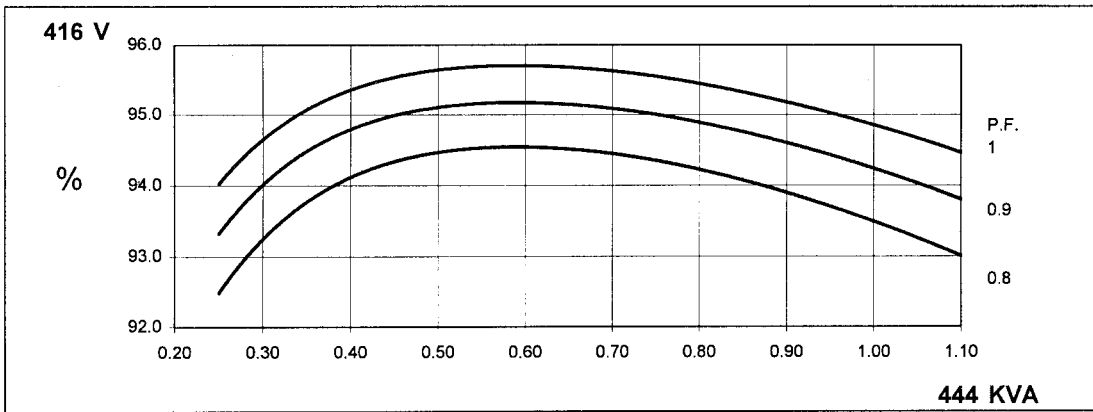

FRAME HC434F HCK434F 50 Hz

SERIES THREE

Three Phase Short Circuit Decrement Curve No-load Excitation at Rated Speed

Based on series star (wye) connection

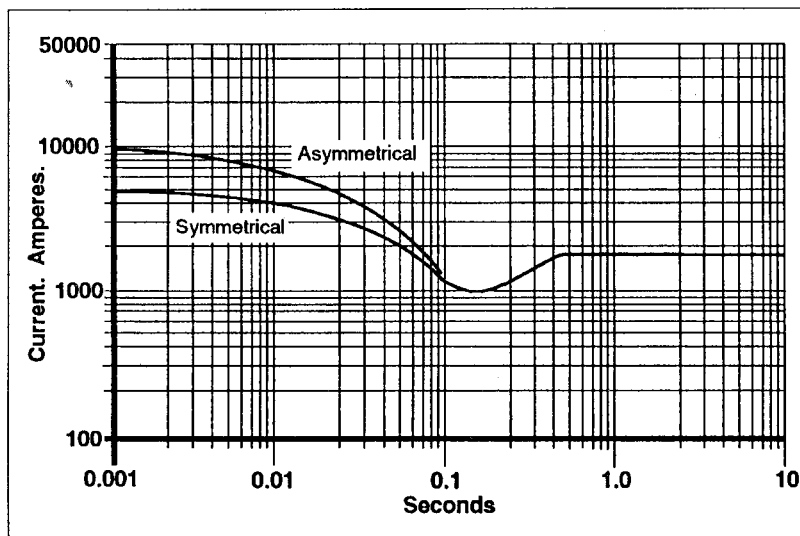

Note 1

The following multiplication factors should be used to adjust the values from curve between time 0.001 seconds and the minimum current point in respect of nominal operating voltage :

VOLTAGE	FACTOR
380 V	X 1.0
400 V	X 1.07
415 V	X 1.12
440 V	X 1.18

The sustained current value is constant irrespective of voltage level.

Note 2

The following multiplication factors should be used to convert the values calculated in accordance with NOTE 1 to those applicable to the various types of short circuit :

	3 PHASE	2 PHASE L-L	1 PHASE L-N
Instantaneous	X 1.00	X 0.87	X 1.30
Minimum	X 1.00	X 1.80	X 3.20
Sustained	X 1.00	X 1.50	X 2.50
Max. sustained duration	10 sec.	5 sec.	2 sec.

All other times are unchanged.

Note 3

Curves are drawn for Series Star (Wye) connected machines. For other connections the following multipliers should be applied to current values shown :

Parallel Star (Wye) Curve current value X 2
Series Delta (Δ) Curve current value X 1.732

Times are unchanged.

FRAME HC434F HCK434F 60 Hz

SERIES THREE

Three Phase Short Circuit Decrement Curve No-load Excitation at Rated Speed

Based on series star (wye) connection

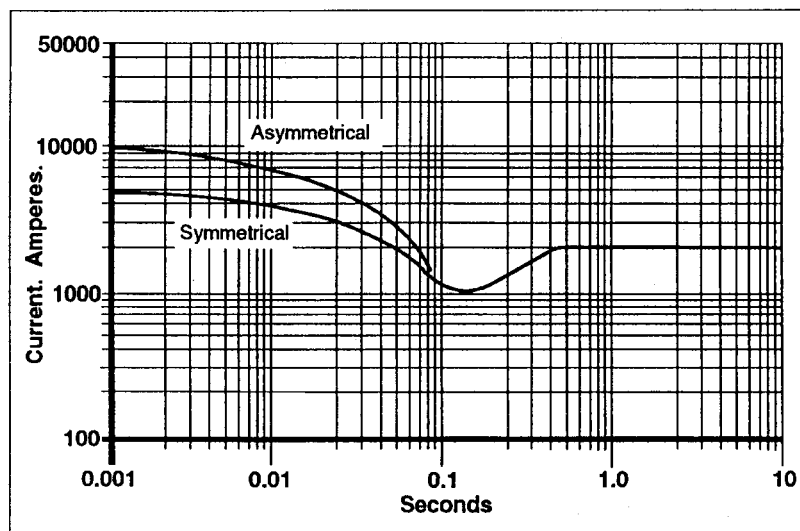

Note 1

The following multiplication factors should be used to adjust the values from curve between time 0.001 seconds and the minimum current point in respect of nominal operating voltage :

VOLTAGE	FACTOR
416 V	X 1.0
440 V	X 1.05
460 V	X 1.08
480 V	X 1.12

The sustained current value is constant irrespective of voltage level.

Note 2

The following multiplication factors should be used to convert the values calculated in accordance with NOTE 1 to those applicable to the various types of short circuit :

	3 PHASE	2 PHASE L-L	1 PHASE L-N
Instantaneous	X 1.00	X 0.87	X 1.30
Minimum	X 1.00	X 1.8	X 3.20
Sustained	X 1.00	X 1.50	X 2.50
Max. sustained duration	10 sec.	5 sec.	2 sec.

All other times are unchanged.

Note 3

Curves are drawn for Series Star (Wye) connected machines. For other connections the following multipliers should be applied to current values shown :

Parallel Star (Wye) Curve current value X 2
Series Delta (Δ) Curve current value X 1.732

Times are unchanged.

NEWAGE
INTERNATIONAL

NEWAGE INTERNATIONAL LIMITED
PO Box 17, Barnack Road, Stamford, Lincolnshire PE9 2NB, England.
Telephone 44 (0) 1780 484000
Telex 32268 Cables Newage Stamford Fax 44 (0) 1780 484100