



ottomotores

PERKINS SERIE 1106

Energía que Mueve al Mundo

Definiciones

Potencia Prime

Estos valores son aplicables para el suministro de energía eléctrica continua (a carga variable) en lugar de la red comercial.

Potencia Stand by

Estos valores son aplicables para el suministro de energía eléctrica continua (a carga variable) en caso de falla de la red comercial. No se permite sobrecarga sobre estos valores.

Tabla de Potencias

Modelo	Voltaje	Prime kVA	Prime kW	Stand-by kVA	Stand-by kW
PNY130	220-440V	151	120	165	132
PNY150	220-440V	169	135	188	150
PNY175	220-440V	200	156	219	175

0.8 Factor de potencia

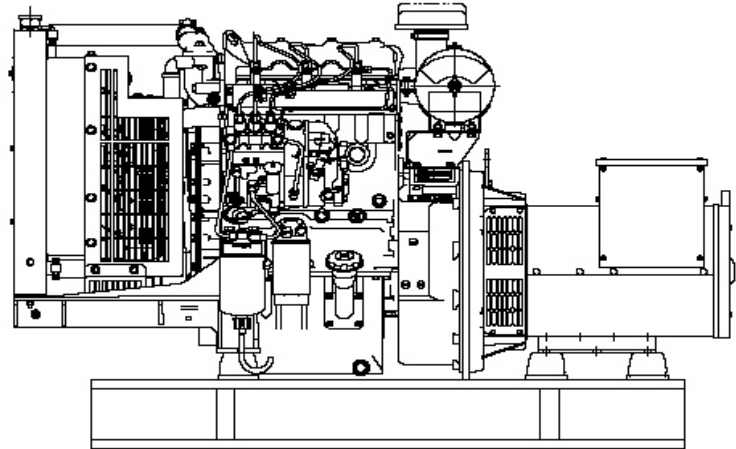

Información Técnica

Datos Técnicos	PNY130	PNY150	PNY175
Frecuencia:	60 Hz	60 Hz	60 Hz
Motor Marca / Modelo	Perkins 1006TAG	Perkins 1106D-E66TAG3	Perkins 1106D-E66TAG4
Generador Marca/Modelo:	Stamford UCI224E	Stamford UCI224F	Stamford UCI224G
Numero de polos del Generador:	4 polos	4 polos	4 polos
Tipo de aislamiento del Generador:	Tipo H	Tipo H	Tipo H
Número de Cilindros del motor:	6 en V	6 en V	6 en V
Diametro por Carrera :in (mm)	4.13 X 5.0 (105X127)	4.13 X 5.0 (105X127)	4.13 X 5.0 (105X127)
Relación de Compresión:	17.0 : 1	16.2:1	16.2:1
Aspiración:	Turbo y postenfriado	Turbo y postenfriado	Turbo y postenfriado
Velocidad:	1800 RPM	1800 RPM	1800 RPM
Potencia del motor: kWm	158.5	171.4	204.3
Presion Efectiva: Lbf/in ² (kPA)	1836 (266)	1731 (251.1)	2065.0 (299.5)
Velocidad de Piston: ft/s (m/s)	7.62 (25)	7.62 (25)	7.62 (25)
Consumo de combustible : lt / hr - 100%	37.7	43	52
Calor Expulsado en el Sistema de Escape : BTU/min (kW)	9394 (147.6)	7735.4 (135.9)	9608.0 (168.8)
Calor Expulsado en el Sistema de Enfriamiento: BTU/min (kW)	4362 (76.7)	4559.3 (80.1)	5322.0 (93.5)
Temperatura de Escape: °F (°C)	1023.8 (551)	876.2 (469.0)	999.3 (537.4)
Flujo de Enfriamiento en el Radiador m ³ /min	182.0	313.8	313.8
Flujo de Escape:m ³ /min (ft ³ /min)	31.41 (1109.1)	30.7 (1084.2)	35.5 (1523.7)
Dimensiones (Largo x Ancho x Alto)cm	220x86x132	220x86x132	220x86x132
Peso Aprox. humedo kg.	1001	1400	1450

Como leer nuestro codigo: Ejem: **PNY30**

P=Motor Perkins
N=Generador Newage Stamford
E=50Hz-1500 RPM
Y=60Hz-1800 RPM
30= Potencia del Equipo.

Los equipos en foto pudieran incluir accesorios opcionales



Energía que Mueve al Mundo



Ottomotores, S.A de C.V.

Calz. San Lorenzo No.1150
Col. Cerro de la estrella, C.P. 09860
Delg. Iztapalapa México, D.F.
Tels:52-55-5624-5600

Fax: 52-55-5426-5521 / 52-55-5426-5581

ventas@ottomotores.com.mx

www.ottomotores.com.mx



UCI274F - Technical Data Sheet

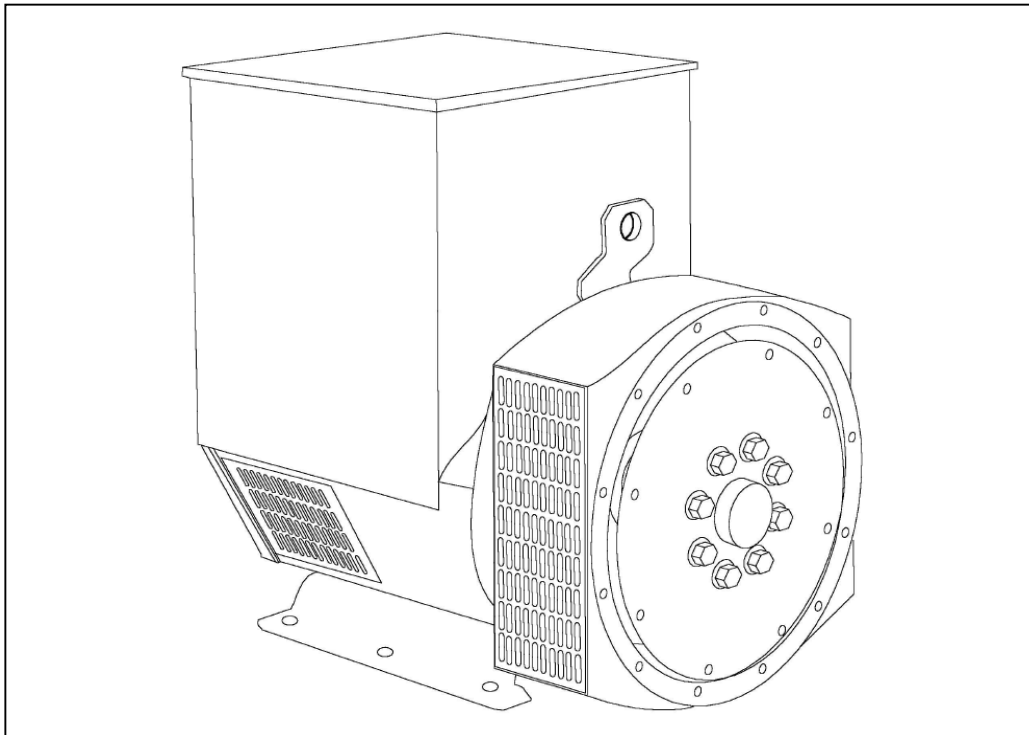

UCI274F

SPECIFICATIONS & OPTIONS



STANDARDS

Newage Stamford industrial generators meet the requirements of BS EN 60034 and the relevant section of other international standards such as BS5000, VDE 0530, NEMA MG1-32, IEC34, CSA C22.2-100, AS1359. Other standards and certifications can be considered on request.

VOLTAGE REGULATORS

SX460 AVR - STANDARD

With this self excited control system the main stator supplies power via the Automatic Voltage Regulator (AVR) to the exciter stator. The high efficiency semiconductors of the AVR ensure positive build-up from initial low levels of residual voltage.

The exciter rotor output is fed to the main rotor through a three phase full wave bridge rectifier. This rectifier is protected by a surge suppressor against surges caused, for example, by short circuit.

SX440 AVR

With this self-excited system the main stator provides power via the AVR to the exciter stator. The high efficiency semi-conductors of the AVR ensure positive build-up from initial low levels of residual voltage.

The exciter rotor output is fed to the main rotor through a three-phase full-wave bridge rectifier. The rectifier is protected by a surge suppressor against surges caused, for example, by short circuit or out-of-phase paralleling.

The SX440 will support a range of electronic accessories, including a 'droop' Current Transformer (CT) to permit parallel operation with other ac generators.

If 3-phase sensing is required with the self-excited system, the SX421 AVR must be used.

SX421AVR

This AVR also operates in a self-excited system. It combines all the features of the SX440 with, additionally, three-phase rms sensing for improved regulation and performance. Over voltage protection is provided via a separate circuit breaker. An engine relief load acceptance feature is built in as standard.

MX341 AVR

This sophisticated AVR is incorporated into the Stamford Permanent Magnet Generator (PMG) control system.

The PMG provides power via the AVR to the main exciter, giving a source of constant excitation power independent of generator output. The main exciter output is then fed to the main rotor, through a full wave bridge, protected by a surge suppressor. The AVR has in-built protection against sustained over-excitation, caused by internal or external faults. This de-excites the machine after a minimum of 5 seconds.

An engine relief load acceptance feature can enable full load to be applied to the generator in a single step.

If three-phase sensing is required with the PMG system the MX321 AVR must be used.

We recommend three-phase sensing for applications with greatly unbalanced or highly non-linear loads.

MX321 AVR

The most sophisticated of all our AVRs combines all the features of the MX341 with, additionally, three-phase rms sensing, for improved regulation and performance.

Over voltage protection is built-in and short circuit current level adjustments is an optional facility.

WINDINGS & ELECTRICAL PERFORMANCE

All generator stators are wound to 2/3 pitch. This eliminates triplen (3rd, 9th, 15th ...) harmonics on the voltage waveform and is found to be the optimum design for trouble-free supply of non-linear loads. The 2/3 pitch design avoids excessive neutral currents sometimes seen with higher winding pitches, when in parallel with the mains. A fully connected damper winding reduces oscillations during paralleling. This winding, with the 2/3 pitch and carefully selected pole and tooth designs, ensures very low waveform distortion.

TERMINALS & TERMINAL BOX

Standard generators are 3-phase reconnectable with 12 ends brought out to the terminals, which are mounted on a cover at the non-drive end of the generator. A sheet steel terminal box contains the AVR and provides ample space for the customers' wiring and gland arrangements. It has removable panels for easy access.

SHAFT & KEYS

All generator rotors are dynamically balanced to better than BS6861:Part 1 Grade 2.5 for minimum vibration in operation. Two bearing generators are balanced with a half key.

INSULATION/IMPREGNATION

The insulation system is class 'H'.

All wound components are impregnated with materials and processes designed specifically to provide the high build required for static windings and the high mechanical strength required for rotating components.

QUALITY ASSURANCE

Generators are manufactured using production procedures having a quality assurance level to BS EN ISO 9001.

The stated voltage regulation may not be maintained in the presence of certain radio transmitted signals. Any change in performance will fall within the limits of Criteria 'B' of EN 61000-6-2:2001. At no time will the steady-state voltage regulation exceed 2%.

NB Continuous development of our products entitles us to change specification details without notice, therefore they must not be regarded as binding.

Front cover drawing typical of product range.

UCI274F WINDING 311

CONTROL SYSTEM		SEPARATELY EXCITED BY P.M.G.							
A.V.R.		MX321	MX341						
VOLTAGE REGULATION		± 0.5 %	± 1.0 %	With 4% ENGINE GOVERNING					
SUSTAINED SHORT CIRCUIT		REFER TO SHORT CIRCUIT DECREMENT CURVES (page 7)							
CONTROL SYSTEM		SELF EXCITED							
A.V.R.		SX460	SX440	SX421					
VOLTAGE REGULATION		± 1.5 %	± 1.0 %	± 0.5 %	With 4% ENGINE GOVERNING				
SUSTAINED SHORT CIRCUIT		SERIES 4 CONTROL DOES NOT SUSTAIN A SHORT CIRCUIT CURRENT							
INSULATION SYSTEM		CLASS H							
PROTECTION		IP23							
RATED POWER FACTOR		0.8							
STATOR WINDING		DOUBLE LAYER CONCENTRIC							
WINDING PITCH		TWO THIRDS							
WINDING LEADS		12							
STATOR WDG. RESISTANCE		0.024 Ohms PER PHASE AT 22°C SERIES STAR CONNECTED							
ROTOR WDG. RESISTANCE		1.52 Ohms at 22°C							
R.F.I. SUPPRESSION		BS EN 61000-6-2 & BS EN 61000-6-4, VDE 0875G, VDE 0875N. refer to factory for others							
WAVEFORM DISTORTION		NO LOAD < 1.5% NON-DISTORTING BALANCED LINEAR LOAD < 5.0%							
MAXIMUM OVERSPEED		2250 Rev/Min							
BEARING DRIVE END		BALL. 6315-2RS (ISO)							
BEARING NON-DRIVE END		BALL. 6310-2RS (ISO)							
		1 BEARING				2 BEARING			
WEIGHT COMP. GENERATOR		530 kg				545 kg			
WEIGHT WOUND STATOR		200 kg				200 kg			
WEIGHT WOUND ROTOR		188.67 kg				177.71 kg			
WR ² INERTIA		1.555 kgm ²				1.5044 kgm ²			
SHIPPING WEIGHTS in a crate		563 kg				577 kg			
PACKING CRATE SIZE		105 x 67 x 103(cm)				123 x 67 x 103(cm)			
		50 Hz				60 Hz			
TELEPHONE INTERFERENCE		THF<2%				TIF<50			
COOLING AIR		0.514 m ³ /sec 1090 cfm				0.617 m ³ /sec 1308 cfm			
VOLTAGE SERIES STAR		380/220	400/231	415/240	440/254	416/240	440/254	460/266	480/277
VOLTAGE PARALLEL STAR		190/110	200/115	208/120	220/127	208/120	220/127	230/133	240/138
VOLTAGE SERIES DELTA		220/110	230/115	240/120	254/127	240/120	254/127	266/133	277/138
KVA BASE RATING FOR REACTANCE VALUES		160	160	160	n/a	181.3	190	190	206.3
Xd DIR. AXIS SYNCHRONOUS		2.24	2.02	1.88	-	2.53	2.37	2.17	2.16
X'd DIR. AXIS TRANSIENT		0.19	0.17	0.16	-	0.21	0.20	0.18	0.18
X''d DIR. AXIS SUBTRANSIENT		0.13	0.12	0.11	-	0.14	0.13	0.12	0.12
Xq QUAD. AXIS REACTANCE		1.38	1.25	1.16	-	1.53	1.43	1.31	1.31
X''q QUAD. AXIS SUBTRANSIENT		0.17	0.15	0.14	-	0.20	0.19	0.17	0.17
X _L LEAKAGE REACTANCE		0.07	0.06	0.06	-	0.09	0.08	0.08	0.08
X ₂ NEGATIVE SEQUENCE		0.14	0.13	0.12	-	0.16	0.15	0.14	0.14
X ₀ ZERO SEQUENCE		0.08	0.08	0.07	-	0.10	0.09	0.09	0.09
REACTANCES ARE SATURATED				VALUES ARE PER UNIT AT RATING AND VOLTAGE INDICATED					
T'd TRANSIENT TIME CONST.		0.035 s							
T''d SUB-TRANSTIME CONST.		0.011 s							
T'do O.C. FIELD TIME CONST.		0.9 s							
T _a ARMATURE TIME CONST.		0.009 s							
SHORT CIRCUIT RATIO		1/Xd							

**50
Hz**

UCI274F
Winding 311



THREE PHASE EFFICIENCY CURVES

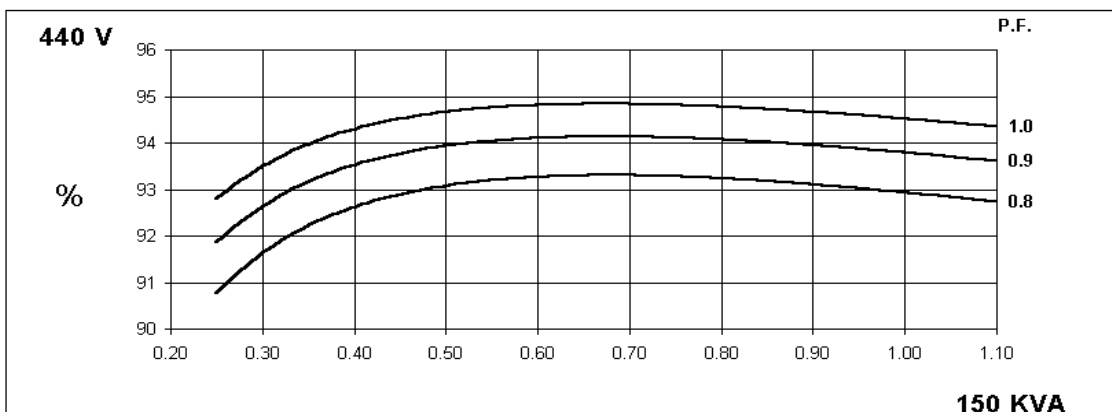
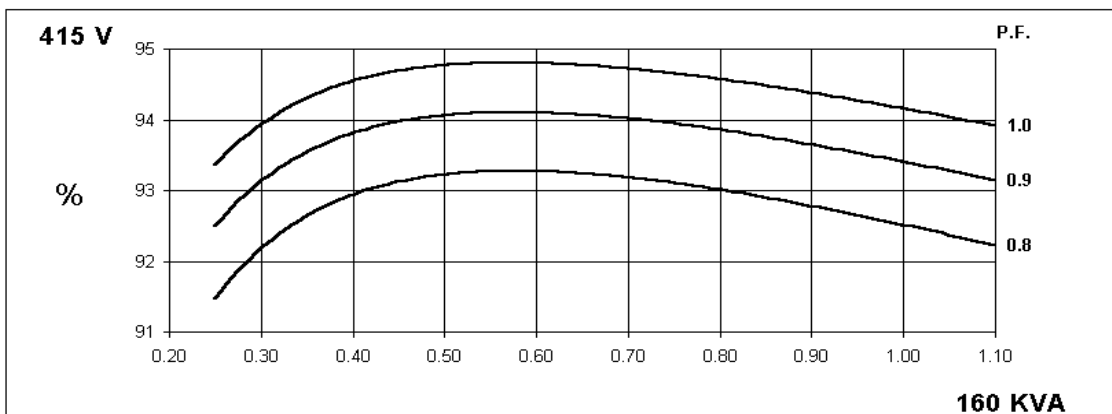
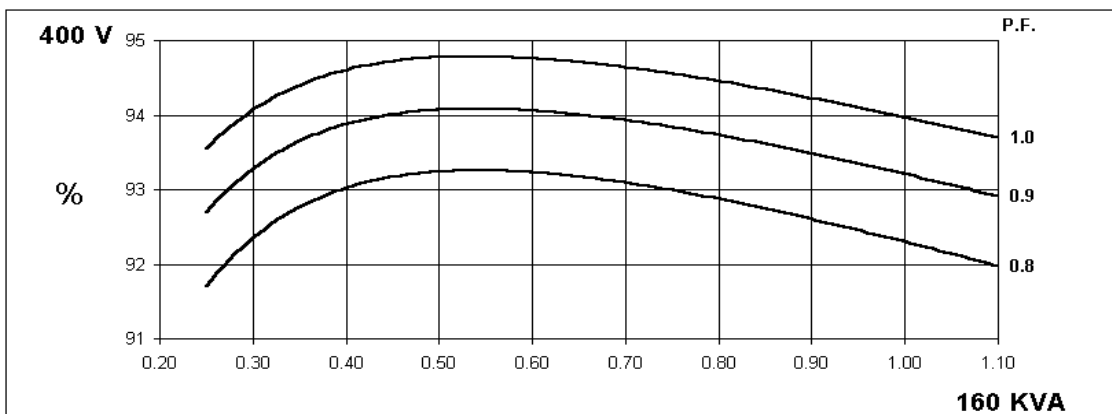
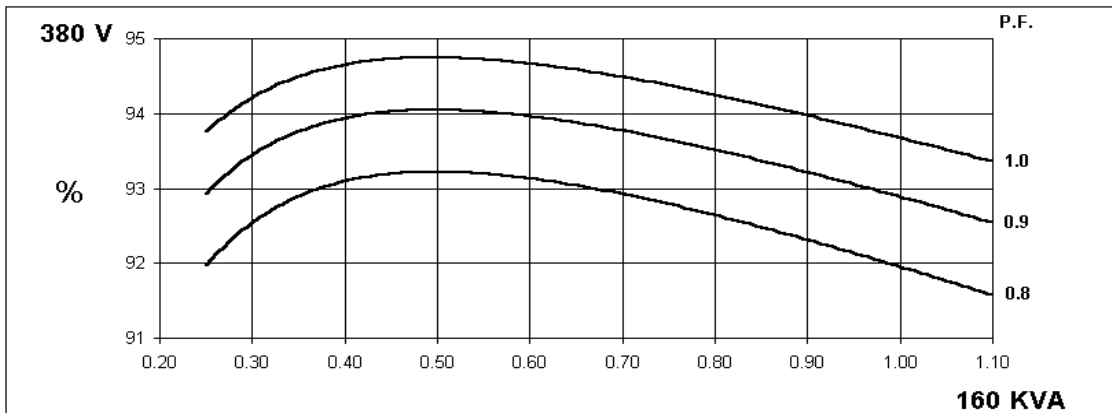

THREE PHASE EFFICIENCY CURVES

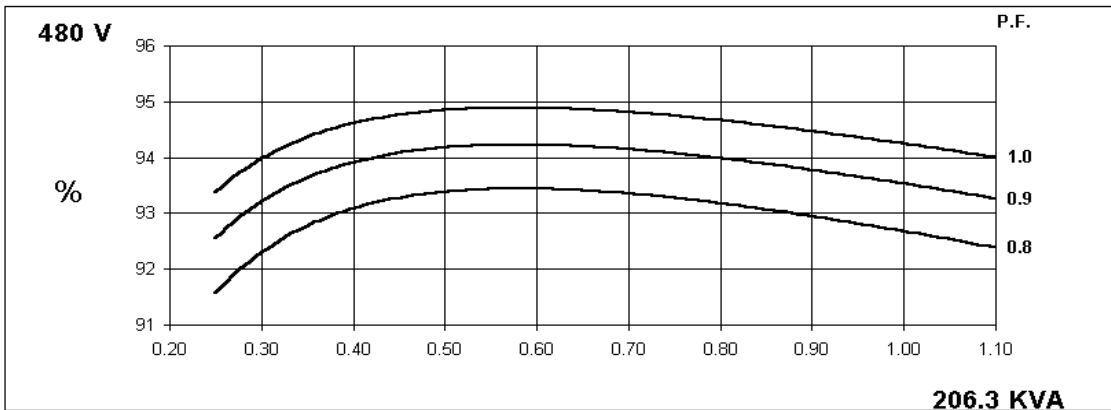
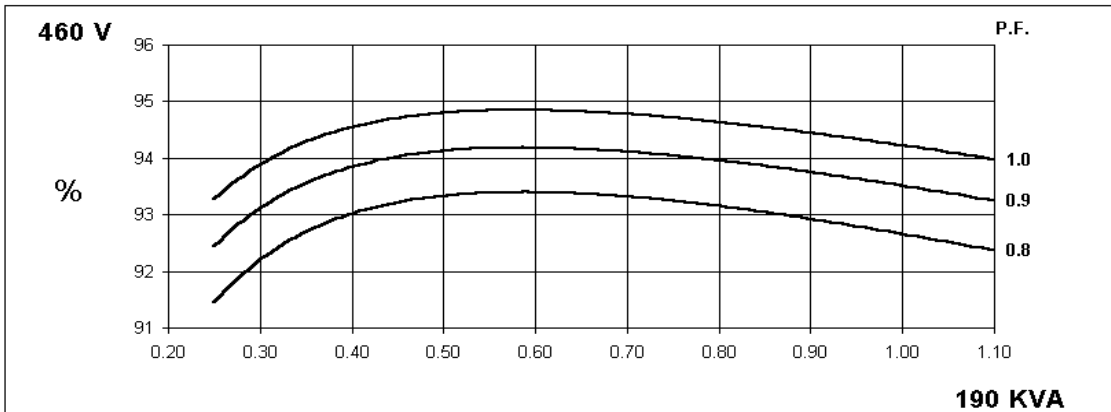
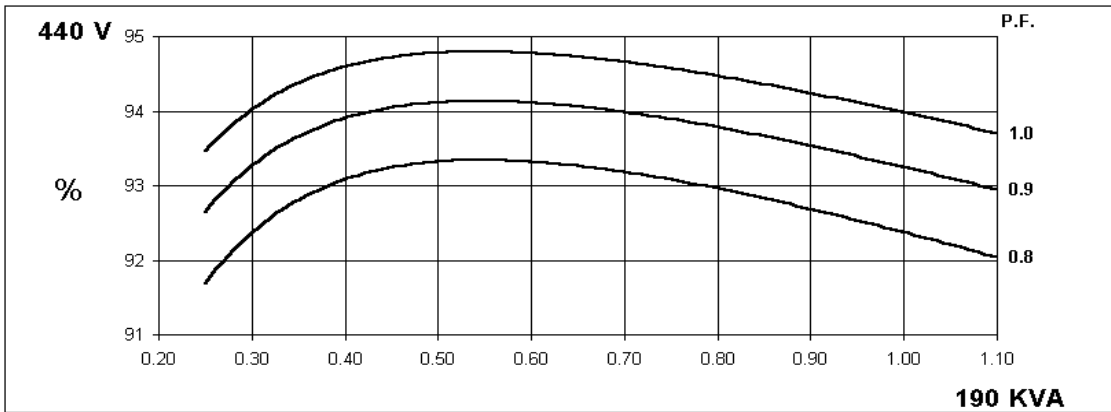
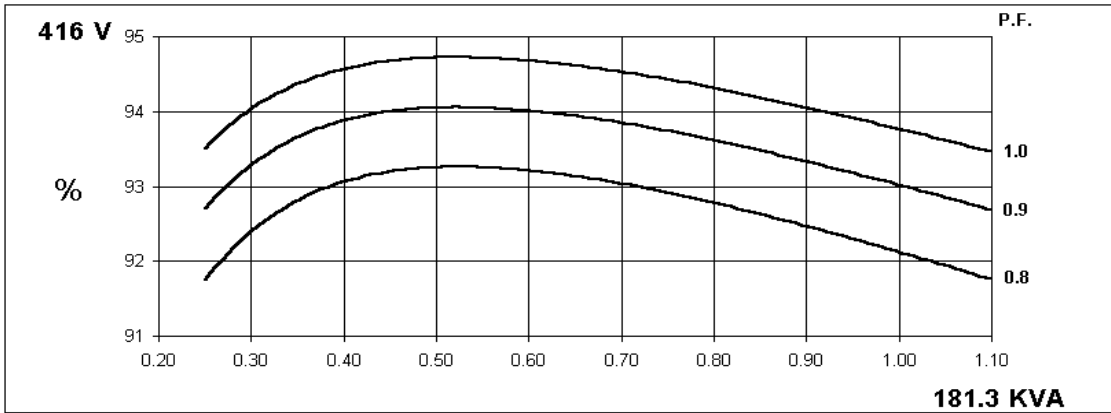

UCI274F

Winding 311



Locked Rotor Motor Starting Curve

**50
Hz**

MX

SX

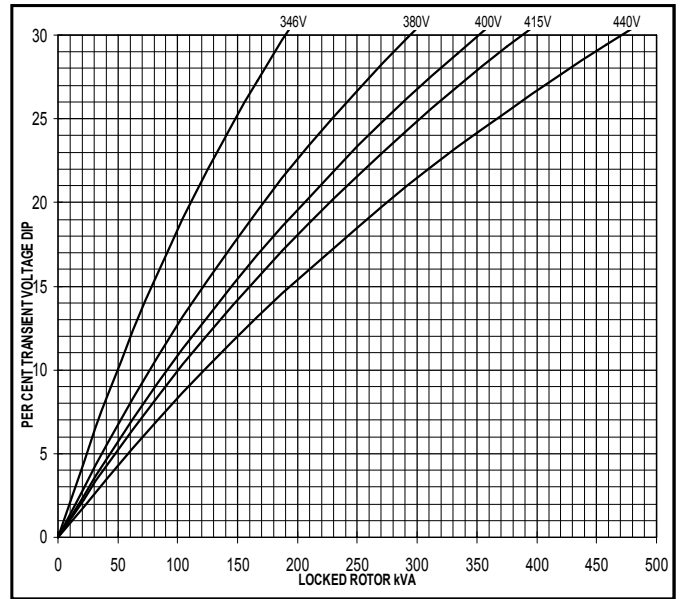
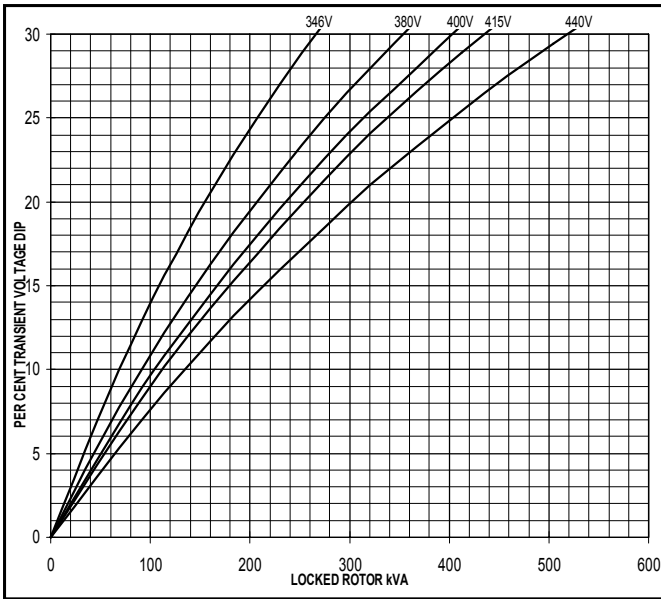

**60
Hz**

MX

SX

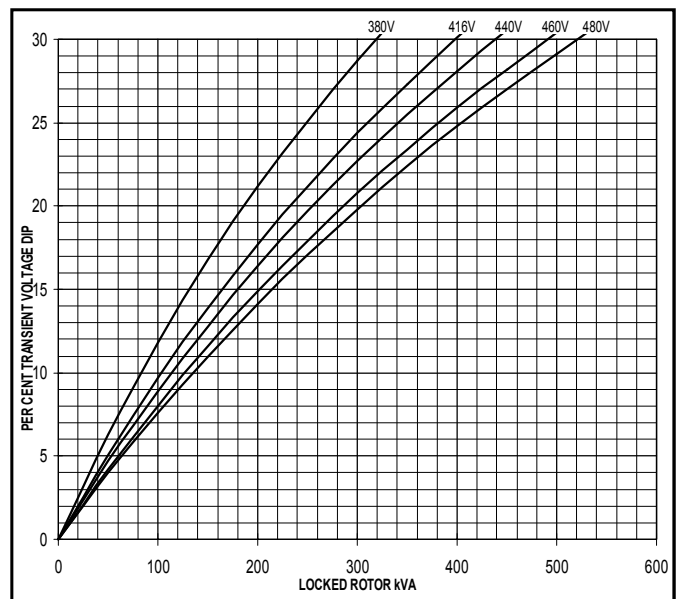
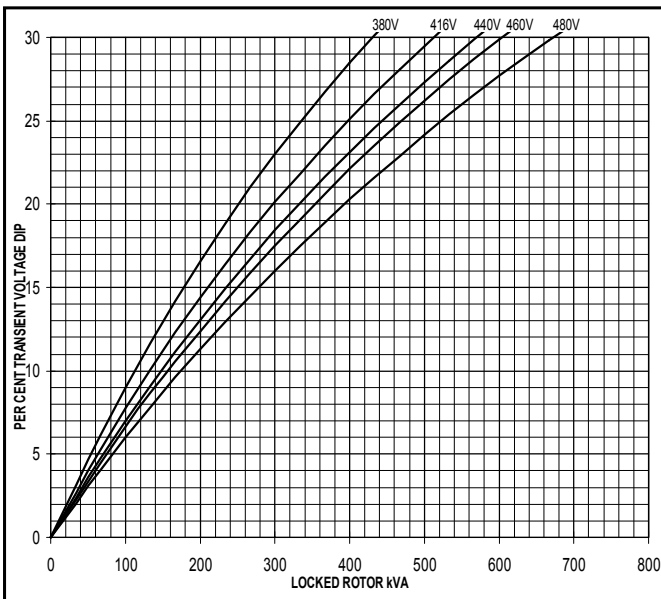

**Three-phase Short Circuit Decrement Curve. No-load Excitation at Rated Speed
Based on star (wye) connection.**

**50
Hz**

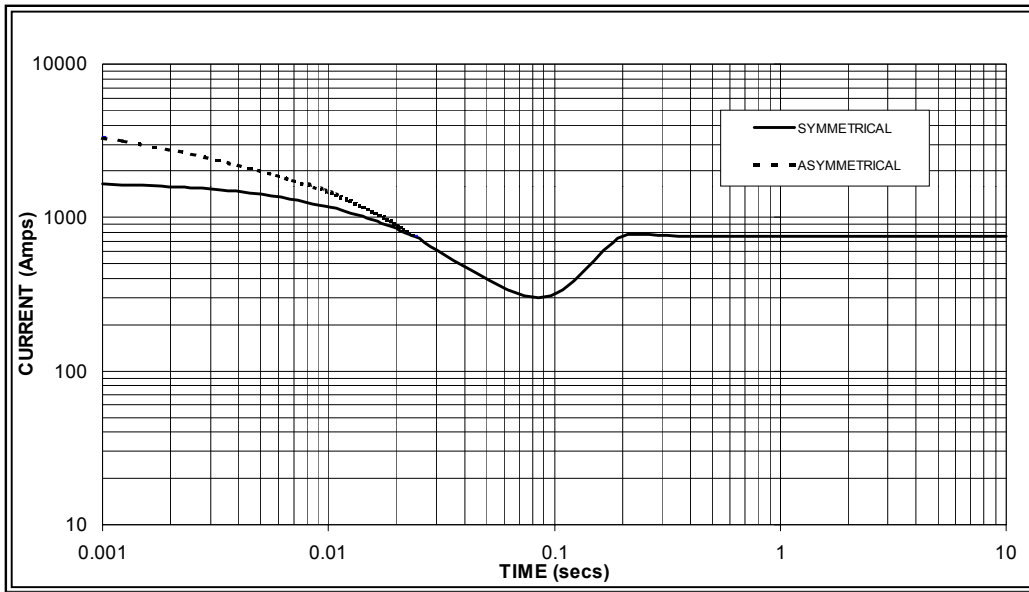

Sustained Short Circuit = 750 Amps

**60
Hz**

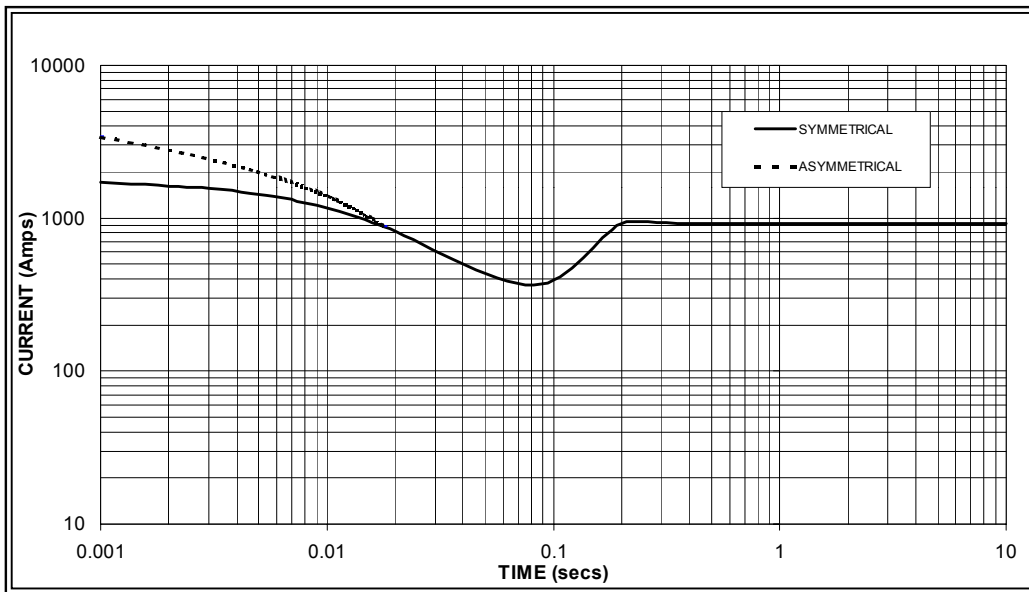

Sustained Short Circuit = 920 Amps

Note 1

The following multiplication factors should be used to adjust the values from curve between time 0.001 seconds and the minimum current point in respect of nominal operating voltage :

50Hz		60Hz	
Voltage	Factor	Voltage	Factor
380v	X 1.00	416v	X 1.00
400v	X 1.07	440v	X 1.06
415v	X 1.12	460v	X 1.12
440v	X 1.18	480v	X 1.17

The sustained current value is constant irrespective of voltage level

Note 2

The following multiplication factor should be used to convert the values calculated in accordance with NOTE 1 to those applicable to the various types of short circuit :

	3-phase	2-phase L-L	1-phase L-N
Instantaneous	x 1.00	x 0.87	x 1.30
Minimum	x 1.00	x 1.80	x 3.20
Sustained	x 1.00	x 1.50	x 2.50
Max. sustained duration	10 sec.	5 sec.	2 sec.

All other times are unchanged

Note 3

Curves are drawn for Star (Wye) connected machines. For other connection the following multipliers should be applied to current values as shown :

Parallel Star = Curve current value X 2

Series Delta = Curve current value X 1.732

UCI274F

Winding 311 / 0.8 Power Factor



RATINGS

Class - Temp Rise	Cont. F - 105/40°C				Cont. H - 125/40°C				Standby - 150/40°C				Standby - 163/27°C				
50 Hz	Series Star (V)	380	400	415	440	380	400	415	440	380	400	415	440	380	400	415	440
	Parallel Star (V)	190	200	208	220	190	200	208	220	190	200	208	220	190	200	208	220
	Series Delta (V)	220	230	240	254	220	230	240	254	220	230	240	254	220	230	240	254
kVA	145.0	145.0	145.0	n/a	160.0	160.0	160.0	n/a	170.0	170.0	170.0	n/a	175.0	175.0	175.0	n/a	
kW	116.0	116.0	116.0	n/a	128.0	128.0	128.0	n/a	136.0	136.0	136.0	n/a	140.0	140.0	140.0	n/a	
Efficiency (%)	92.3	92.6	92.8	n/a	92.0	92.3	92.5	n/a	91.7	92.1	92.3	n/a	91.6	92.0	92.2	n/a	
kW Input	125.7	125.3	125.0	n/a	139.1	138.7	138.4	n/a	148.3	147.7	147.3	n/a	152.8	152.2	151.8	n/a	

60 Hz	Series Star (V)	416	440	460	480	416	440	460	480	416	440	460	480	416	440	460	480
	Parallel Star (V)	208	220	230	240	208	220	230	240	208	220	230	240	208	220	230	240
	Series Delta (V)	240	254	266	277	240	254	266	277	240	254	266	277	240	254	266	277
kVA	162.5	172.5	172.5	187.5	181.3	190.0	190.0	206.3	187.5	200.0	200.0	212.5	192.5	206.3	206.3	218.8	
kW	130.0	138.0	138.0	150.0	145.0	152.0	152.0	165.0	150.0	160.0	160.0	170.0	154.0	165.0	165.0	175.0	
Efficiency (%)	92.5	92.7	92.9	92.9	92.1	92.4	92.7	92.7	92.0	92.2	92.5	92.6	91.9	92.1	92.4	92.5	
kW Input	140.5	148.9	148.5	161.5	157.5	164.5	164.0	178.0	163.0	173.5	173.0	183.6	167.6	179.2	178.6	189.2	

DIMENSIONS

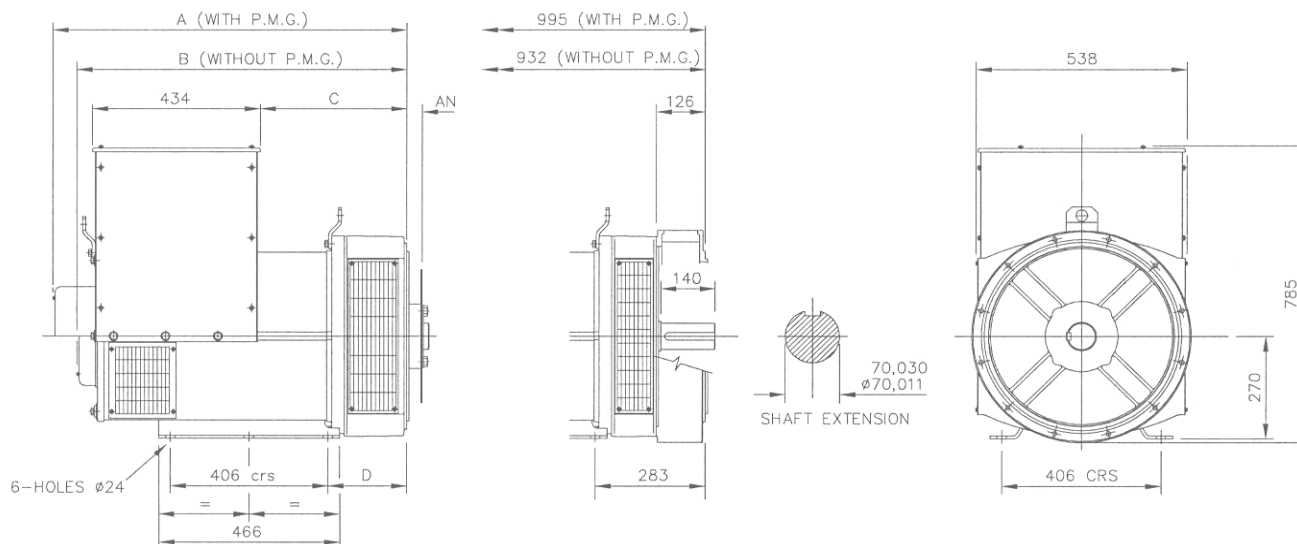

SINGLE BEARING ADAPTORS				
ADAPTOR	A	B	C	D
SAE 1	928,3	865,3	389,3	216,3
SAE 2	914	851	375	202
SAE 3	914	851	375	202

COUPLING DISCS	
DISC	AN
SAE 10	53,98
SAE 11,5	39,68
SAE 14	25,40



PO Box 17 • Barnack Road • Stamford • Lincolnshire • PE9 2NB

Tel: 00 44 (0)1780 484000 • Fax: 00 44 (0)1780 484100

Website: www.newage-avkseg.com

Technical Data

1100D Series

Electropak

1106D-E66TAG3

159,4 kWm @ 1800 rev/min

Basic technical data

Number of cylinders 6
 Cylinder arrangement In-Line
 Cycle 4 Strokes
 Induction system Turbocharged and Air Charge Cooled
 Combustion system Direct Injection Diesel
 Compression ratio 16,2:1
 Bore 105 mm (4.1 in)
 Stroke 127 mm (5.0 in)
 Cubic capacity 6,6 litres (402.8 in³)
 Direction of rotation Clockwise
 Firing order 1 5 3 6 2 4

Estimated total weight

-dry 788 kg (1737 lb)
 -wet 822 kg (1812 lb)

Overall dimensions

-height 1140,4 mm (44.9 in)
 -length (air cleaner fitted) 1728,3 mm (68.0 in)
 -width 779,8 mm (30.7 in)

Moments of inertia

Engine rotational components 0,27 kg m²
 Flywheel 1,31 kg m²

Centre of gravity (wet)

Forward from rear of block 476,3 mm (18.8 in)
 Above crankshaft centre line 176,3 mm (6.9 in)
 Offset to RHS of crankshaft centre line 17,0 mm (0.66 in)

Performance

Note: All data based on operation to ISO 14396 and ISO 3046/1 standard reference conditions.

Speed variation at constant load ± 3%

Cyclic irregularity at 110% stand-by power

-1800 rev/min 0,023

Test conditions

-air temperature 25 °C (77 °F)
 -barometric pressure 100 kPa (29.5 in hg)
 -relative humidity 31,5 %

Sound level

Average sound pressure level 100% Prime Power load for
 -Electropak at 1 metre 100,2 dB(A)
 All ratings certified to within ± 3%

If the engine is to operate in ambient conditions other than those of the test conditions, suitable adjustments must be made for these changes. For full details, contact Perkins Technical Service Department.

General installation

Designation	Units	Type of operation and application	
		Prime	Standby
		60Hz	
Gross engine power	kWb (bhp)	154,4 (207.1)	171,4 (229.9)
Brake mean effective pressure	kPa (lbf/in ²)	1560,0 (226.3)	1731,0 (251.1)
Mean piston speed	m/s (ft/s)	7,62 (25.0)	
Electropak net engine power	kWm (bhp)	142,4 (191.0)	159,4 (213.8)
Engine coolant flow (against 35 kPa restriction)	l/min (UK gal/min)	170,0 (37.4)	
Combustion air flow (at STP)	m ³ /min (ft ³ /min)	12,4 (437.9)	12,7 (448.5)
Exhaust gas flow (max)	m ³ /min (ft ³ /min)	29,5 (1041.8)	30,7 (1084.2)
Exhaust gas temperature (max) in manifold (after turbocharger)	°C (°F)	455,2 (851.4)	469,0 (876.2)
Net engine thermal efficiency	%	36,0	37,0
Typical genset electrical output (0.8pf 25 °C)	kWe	135,0	150,0
	kVA	169,0	188,0
Regenerative Power (estimated)	kW (bhp)	14,9 (20.0)	
Assumed alternator efficiency	%	92,2	91,8
Energy balance			
Power in fuel (fuel heat of combustion)	kWt (bhp)	400,9 (537.6)	435,9 (584.6)
	Btu/min	22819,1	24811,3
Power to cooling fan	kWm (bhp)	12,0 (16.1)	
	Btu/min	683,0	
Power to coolant and lubricating oil	kWt (bhp)	74,2 (99.5)	80,1 (107.4)
	Btu/min	4223,4	4559,3
Power to exhaust	kWt (bhp)	127,3 (170.7)	135,9 (182.2)
	Btu/min	7245,9	7735,4
Energy to charge coolers	kWt (bhp)	32,5 (43.6)	35,0 (46.9)
	Btu/min	1849,9	1992,2
Power to radiation	kWt (bhp)	12,4 (16.6)	13,5 (18.1)
	Btu/min	705,8	768,4

1106D-E66TAG3 - Left side view

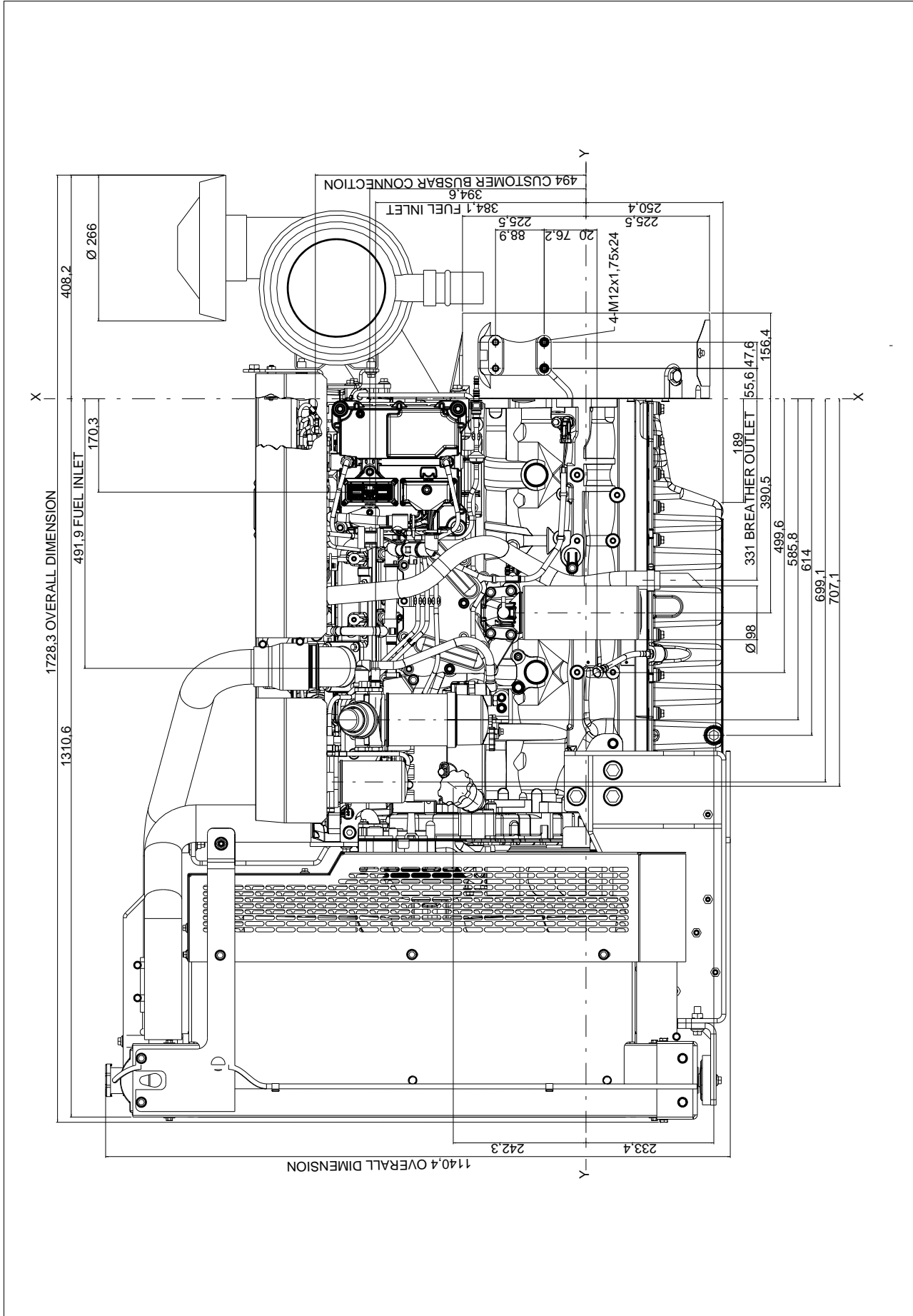

1106D-E66TAG3 - Front view

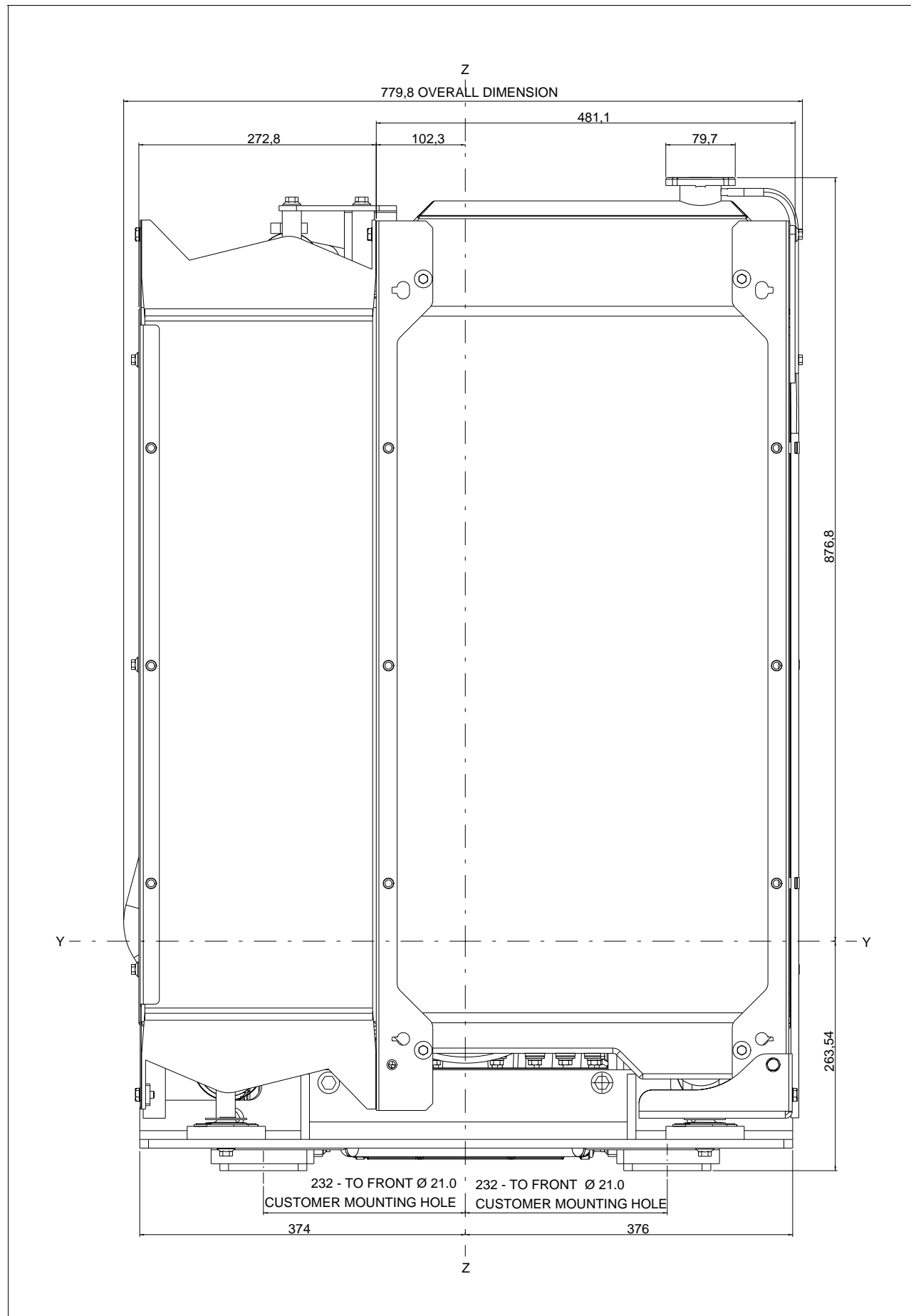

1106D-E66TAG3 - Right side view

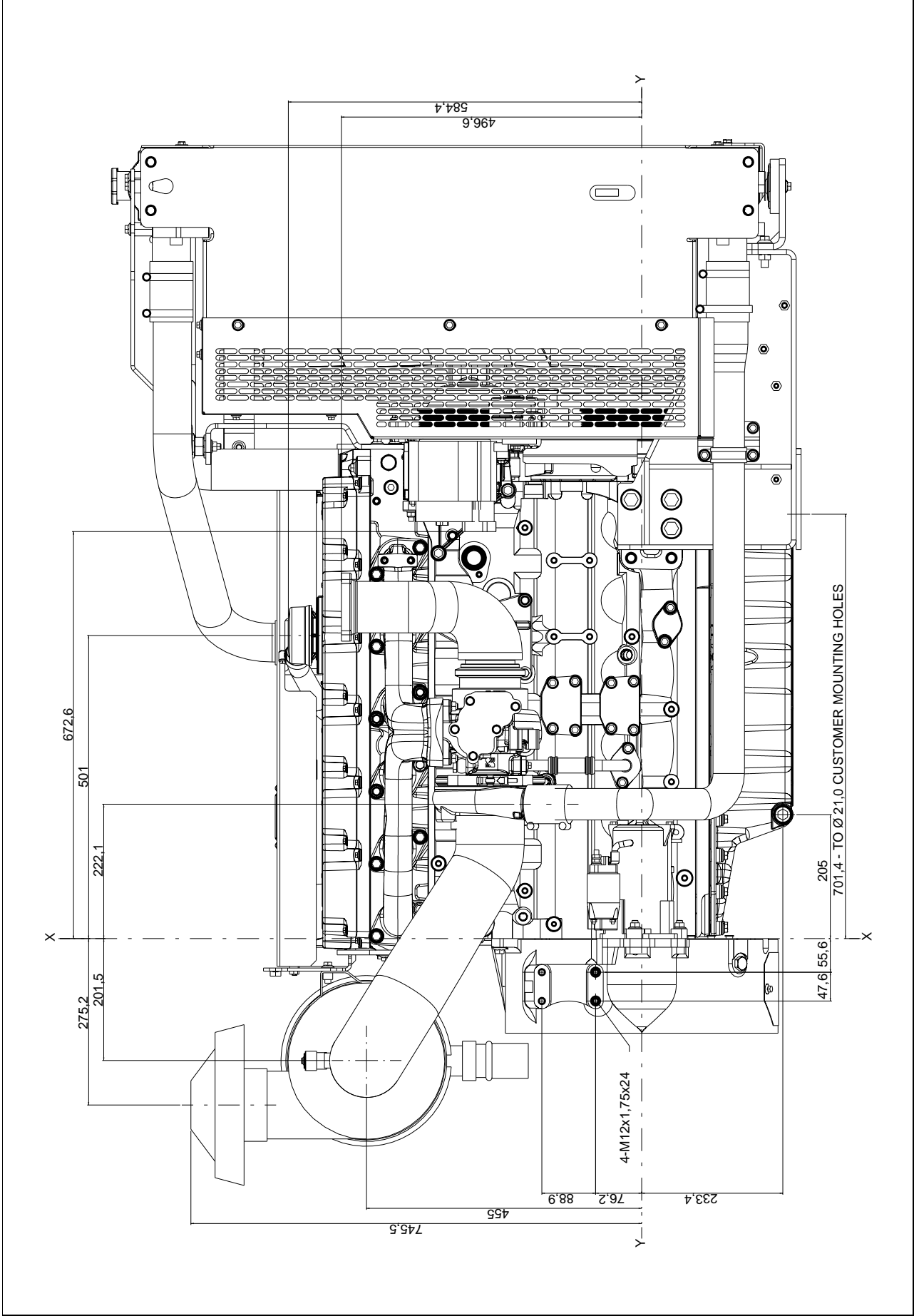

1106D-E66TAG3 - Rear view

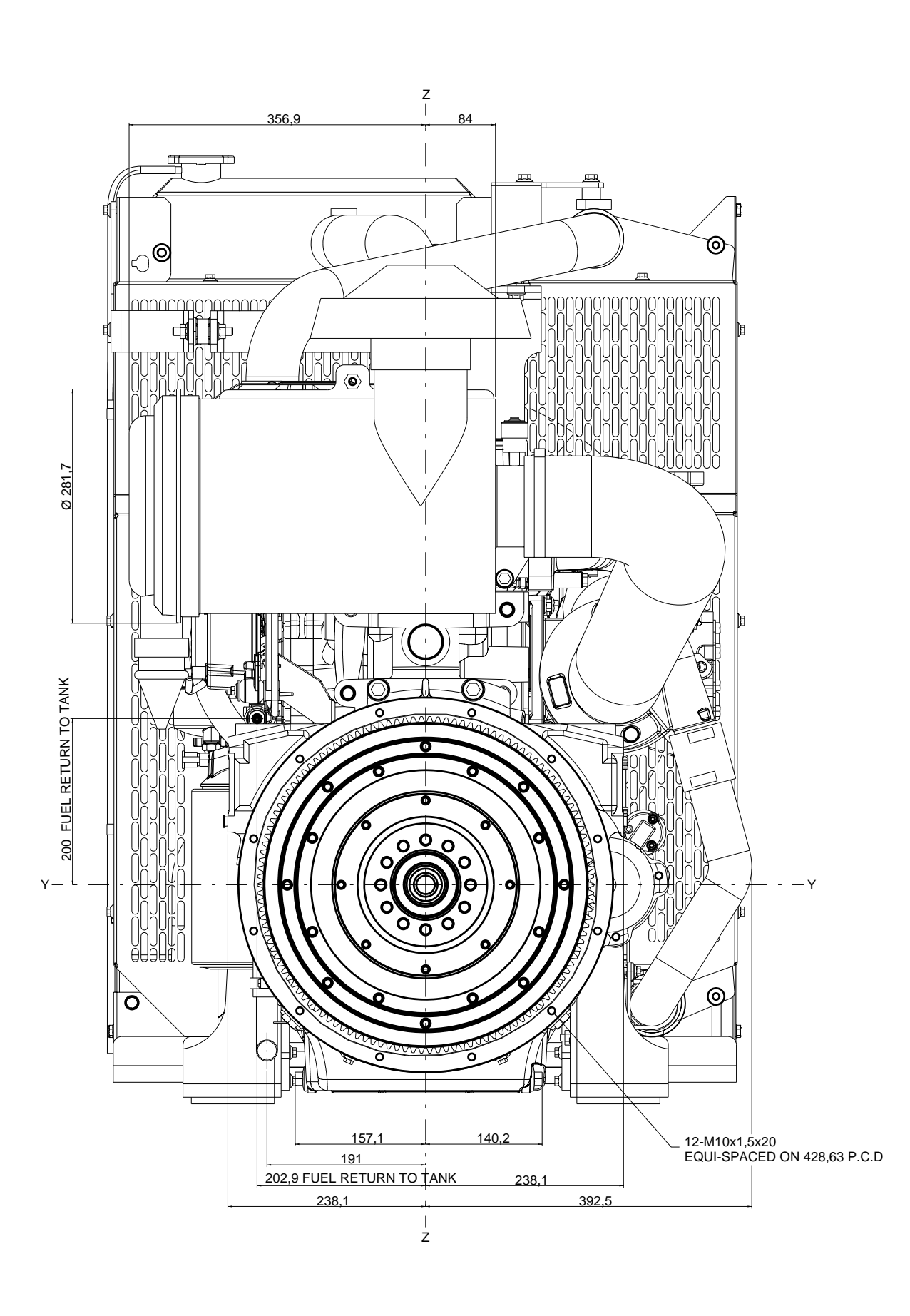

1106D-E66TAG3 - Plan view

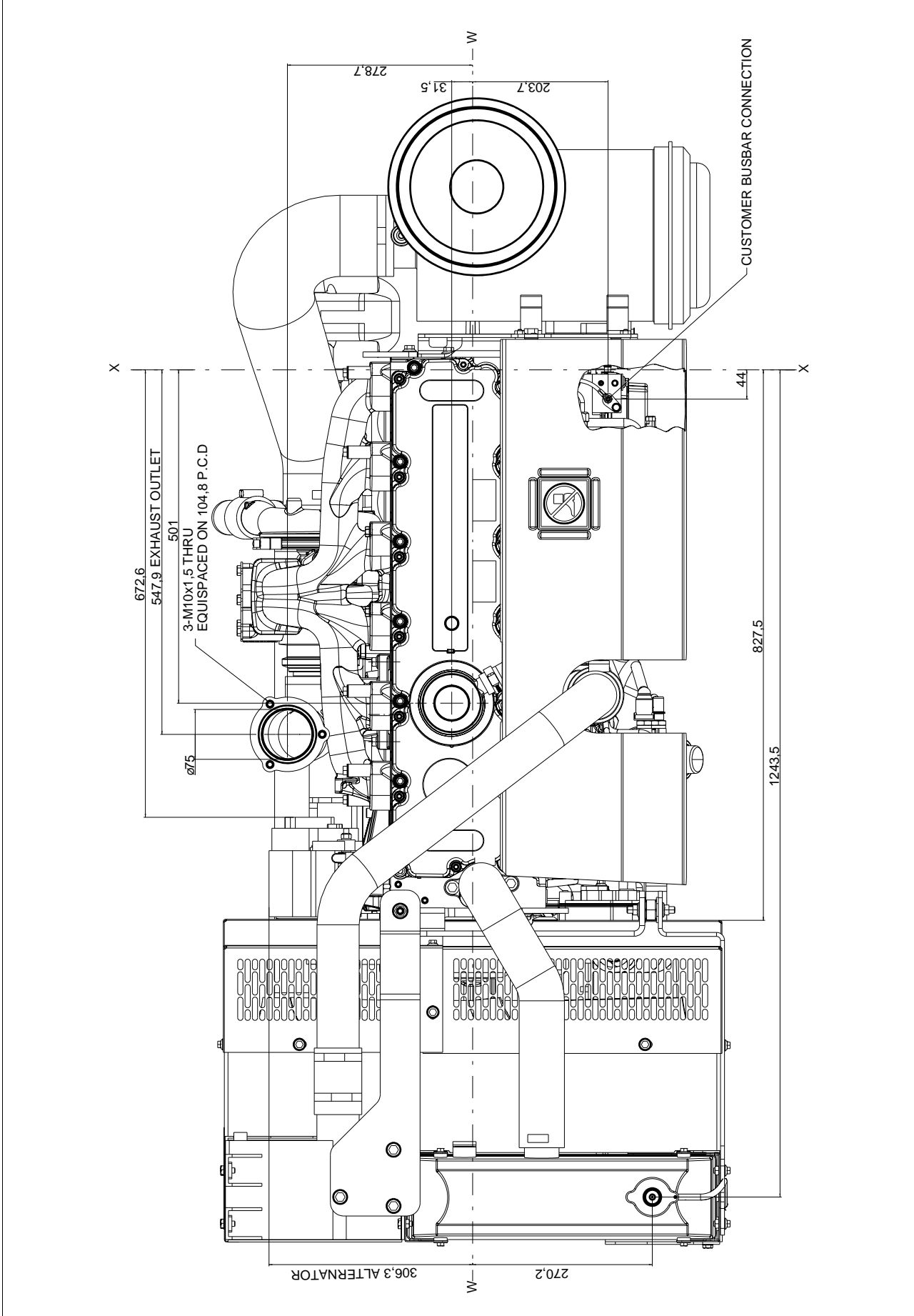

Cooling system

Cooling pack

-overall weight (wet) 71 kg
 -overall face area 554760 mm²
 -width 745 mm
 -height 1080 mm

Radiator

Face area 351200 mm²
 Number of rows and materials 5 rows, Aluminium
 Matrix density and material 10 fins per inch, Aluminium
 Width of matrix 439 mm (17.3 in)
 Height of matrix 800 mm (31.1 in)
 Pressure cap setting (min) 100 kPa (14.5 lb/in²)

Charge cooler

Face area 203560 mm²
 Number of rows and materials 2 rows, Aluminium
 Matrix density and material 10 fins per inch, Aluminium
 Width of matrix 258 mm
 Height of matrix 789 mm

Fan

Diameter 686 mm (27 in)
 Drive ratio..... 1.2
 Number of blades..... 7
 Material Nylon
 Type Pusher
 Air flow @ 1800 rev/min 313,8 m³/min

Coolant

Total system capacity 21 litres
 System drawdown capacity 10%
 Engine capacity 9,5 litres
 Maximum top tank temperature 112 °C (233.6 °F)
 Temperature rise across engine
 (max, rating dependent) 6,6 to 7,0 °C (43.9 to 44.6 °F)
 Max permissible external system resistance. 35 kPa (5.1 lbf/in²)
 Thermostat operation range.. 82 to 95 °C (179.6 to 203 °F)
 Shutdown switch setting 118 °C (244.4 °F)
 Coolant pump method of drive gears
 Coolant pump flow (against 35 kPa restriction). 170 litres/min
 Recommended coolant immersion heater
 rating (minimum) 0,75 kW
 Recommended coolant
 BS6580 - 1992, ASTM D3306 and ELC coolants to 1E1966

Electrical system

Alternator..... Denso A127i
 Alternator voltage 12 volts
 Alternator output 100 amps
 Starter 29MT
 Starter motor voltage 12 volts
 Starter motor power 3,3 kW
 Number of teeth on the flywheel 126
 Pull-in current of starter motor solenoid
 @ -25 °C max ⁽¹⁾ 102 amps
 Hold-in current of starter motor solenoid
 @ -25 °C max ⁽¹⁾ 15 amps
 Engine stop method via ECM

1 All leads to rated at 10 amps minimum

Cold start recommendations

Minimum required cranking speed over TDC 60 rev/min

Temperature Range	
5 to -10 °C	Oil: 15W40 Starter: 29MT Battery: 1x 900CCA Max breakaway current: 867 amps Cranking current: 404 (560 max) amps Aids: Glowplugs Minimum mean cranking speed: 107 rev/min

Temperature Range	
-10 to -20 °C	Oil: 10W40 Starter: 29MT Battery: 2x 770 CCA Max breakaway current: 984 amps Cranking current: 496 (683 max) amps Aids: Glowplugs Minimum mean cranking speed: 100 rev/min

Temperature Range	
-20 to -25 °C	Oil: 5W40 Starter: 29MT Battery: 2 x770 CCA Max breakaway current: 984 amps Cranking current: 496 (683 max) amps Aids: Glowplugs Minimum mean cranking speed: 100 rev/min

- Battery capacity is defined by the 20 hour rate
- If a change to a low viscosity oil is made, the cranking torque necessary at low ambient temperatures is much reduced. The starting equipment has been selected to take advantage of this. It is important to change to the appropriate multigrade oil in anticipation of operating in low ambient temperatures
- Breakaway current is dependent on battery capacity available. Cables should be capable of handling the transient current which may be up to double the steady cranking current.

Exhaust system

Maximum back pressure @ 1800 rev/min 15,0 kPa (4.4 in Hg)
 Exhaust outlet, internal diameter 90 mm (3.5 in)

Fuel system

Injection components

Injector ... Electronic
 Fuel pump ... CR200

Fuel priming

Priming pump type ... Manual / Electronic
 Maximum priming time ... 90 seconds

Fuel feed

Maximum fuel flow ... 1.5 litres/min
 Maximum suction head at engine fuel pump inlet ... 30 kPa
 Maximum static pressure head ... 600 kPa
 Fuel temperature at engine fuel pump inlet ... 80 °C (176 °F)
 Tolerance on fuel consumption ... + 3%

Fuel specification

Fuel standard ... BS2869, 1998 Class A2 or BS EN590

Fuel consumption

Load		Type of Operation and Application	
		60Hz Prime	60Hz Standby
100%	g/kWhr (l/hr)	218,1 (40.1)	212,1 (43.3)
75%	g/kWhr (l/hr)	229,0 (31.6)	225,6 (34.5)
50%	g/kWhr (l/hr)	245,4 (23.4)	241,5 (24.6)
25%	g/kWhr (l/hr)	269,5 (9.2)	271,4 (13.8)

Induction system

Maximum air intake restriction

-clean filter ... 5 kPa (in H₂O)
 -dirty filter ... 8 kPa (in H₂O)
 -air filter type ... Paper Element

Lubrication system

Maximum total system oil capacity ... 16.5 litres (34.9 UK pints)
 Minimum oil capacity in sump ... 12.5 litres (26.4 UK pints)
 Maximum oil capacity in sump ... 15.5 litres (32.8 UK pints)
 Maximum engine operating angles - front up,
 front down, right side, left side ... 25 °
 Sump drain plug tapping size ... 3/4 - 16 UNF
 Shutdown switch setting (where fitted) ... ECM controlled

Lubricating oil

-relief valve opening pressure ... 430 kPa (62.4 lbf/in²)
 -pressure at maximum speed ... 450 kPa (65.3 lbf/in²)
 -maximum continuous oil temperature (in rail) ... 125 °C
 -oil consumption at full load (% of fuel) ... < 0.1

Recommended SAE viscosity

A multigrade oil must be used which conforms to API-CH-4/CI4.

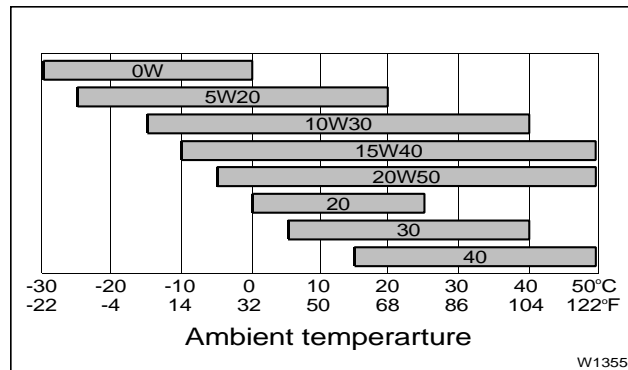

Mountings

Maximum static bending moment at
 -rear face of block ... 1130 Nm (833 lbf ft)
 Maximum permissible overhung load
 on the flywheel ... refer to the applications department
 Maximum bending moment (in shock) at rear face
 -of flywheel housing ... ± 3000 Nm

Load acceptance (cold engine)

The below complies with the requirements of classification 3 and 4 of ISO 8528-12 and G2 operating limits stated in ISO 8528-5

Initial load application when engine reaches rated speed (15 seconds maximum after engine starts to crank)		
Descriptor	Units	1800 rev/min (60 Hz)
% of Prime Power	%	55
Load	kW (kWe)	85 (74.25)
Transient frequency deviation	%	≤ -10
Frequency recovery	seconds	5

The above figures were obtained under the following test conditions:

-engine block temperature ... 15 °C
 -alternator ... 91,8%
 -minimum ambient temperature ... 10 °C
 -governing mode ... Isochronous
 -typical alternator inertia ... 1-3215 kgm²

All tests were conducted using an engine which was installed and serviced to Perkins Engines Company Limited recommendations.

@ Perkins®

Perkins Engines Company Limited
 Peterborough PE1 5NA United Kingdom
 Telephone +44 (0) 1733 583000
 Fax +44 (0) 1733 582240
 www.perkins.com

Distributed by

