



ottomotores

PERKINS SERIE 1104

Energía que Mueve al Mundo

Definiciones

Potencia Prime

Estos valores son aplicables para el suministro de energía eléctrica continua (a carga variable) en lugar de la red comercial.

Potencia Stand by

Estos valores son aplicables para el suministro de energía eléctrica continua (a carga variable) en caso de falla de la red comercial. No se permite sobrecarga sobre estos valores.

Tabla de Potencias

Modelo	Voltaje	Prime kVA	Prime kW	Stand-by kVA	Stand-by kW
PNY80	220-440V	91	73	100	80
PNY100	220-440V	112	90	125	100

0.8 Factor de potencia

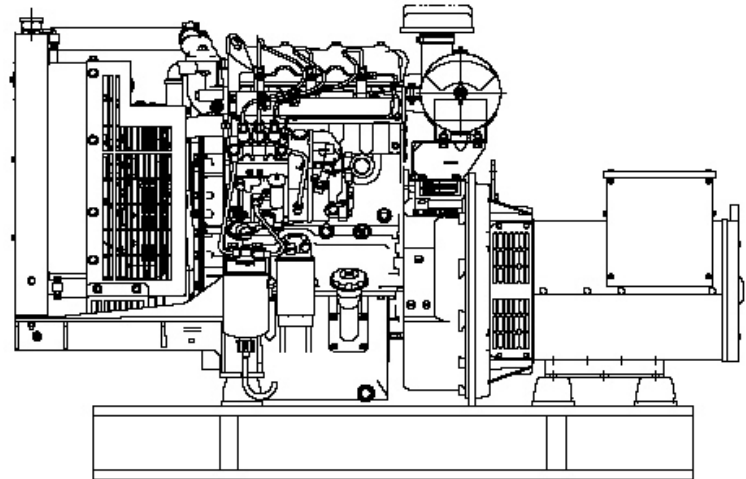

Información Técnica

Datos Técnicos	PNY80	PNY100
Frecuencia:	60 Hz	60 Hz
Motor Marca / Modelo	Perkins 1104A-44TG2	Perkins 1104C-44TAG2
Generador Marca/Modelo:	Stamford UCI224G	Stamford UCI274C
Numero de polos del Generador:	4 polos	4 polos
Tipo de aislamiento del Generador:	Tipo H	Tipo H
Número de Cilindros del motor:	4 en línea	4 en línea
Diametro por Carrera :in (mm)	4.13X4.99 (105X127)	4.13X4.99 (105X127)
Relación de Compresión:	17.25 : 1	18.2:1
Aspiración:	Turbocargado	Turbocargado
Velocidad:	1800 RPM	1800 RPM
Potencia del motor: kW/m	93.0	117.5
Presion Efectiva: Lbf/in ² (kPA)	204.3 (1409)	163.0(1124)
Velocidad de Piston: ft/s (m/s)	25 (7.62)	25 (7.62)
Consumo de combustible: lt / hr - 100%	22.3	26.7
Calor Expulsado en el Sistema de Escape: kW	71.0	99.7
Calor Expulsado en el Sistema de Enfriamiento: kW	57.0	64.0
Temperatura de Escape: °C	560	574
Flujo de Enfriamiento en el Radiador m ³ /min	111.0	225.6
Flujo de Escape: m ³ /min	15.85	20.40
Dimensiones (Largo x Ancho x Alto)cm	202x68x123	202x76x123
Peso Aprox. humedo kg.	899	1001

Los equipos en foto pudieran incluir accesorios opcionales

Como leer nuestro codigo: Ejem: **PNY30**

P=Motor Perkins
 N=Generador Newage Stamford
 E=50Hz-1500 RPM
 Y=60Hz-1800 RPM
 30= Potencia del Equipo.



Ottomotores, S.A de C.V.

Calz. San Lorenzo No.1150
 Col. Cerro de la estrella, C.P. 09860
 Delg. Iztapalapa México, D.F.
 Tels:52-55-5624-5600

Fax: 52-55-5426-5521 / 52-55-5426-5581

ventas@ottomotores.com.mx

www.ottomotores.com.mx



Technical Data

1100 Series

1104C-44TAG2

Diesel Engine Electropak

99,5 kWm @ 1500 rev/min

112,4 kWm @ 1800 rev/min

Basic technical data

Number of cylinders ... 4
 Cylinder arrangement ... In-line
 Cycle ... Four stroke
 Induction system ... Turbocharged, air-to-air charge cooled
 Compression ratio ... 18:23 : 1
 Bore ... 105 mm
 Stroke ... 127 mm
 Cubic capacity ... 4,4 litres
 Direction of rotation ... Anticlockwise viewed on flywheel
 Firing order ... 1, 3, 4, 2

Estimated total weight (fan to flywheel housing)

-Dry ... 401

Overall dimensions (electropak)

-height ... 966 mm
 -length ... 1259 mm
 -width (includes mounting brackets) ... 721 mm

Moments of inertia (mk²)

-engine rotational components ... 0,162 kgm²
 -flywheel ... 1,31 kgm²

Centre of gravity (fan to flywheel housing)

-forward from rear of block ... 227,2 mm
 -above centre line of block ... 160,4 mm
 -offset to RHS of centre line ... 8,1 mm

General installation

Designation	Units	Prime	Stand-by	Prime	Stand-by
		50 Hz	50 Hz	60 Hz	60 Hz
Gross engine power	kWb	93,6	103	106,8	117,5
Brake mean effective pressure	kPa	1702	1873	1618	1780
Engine coolant flow with 35 kPa system restriction	l/min	142		170	
Combustion air flow	m ³ /min	6,01	6,27	7,75	7,80
Exhaust gas flow Max.	m ³ /min	15,2	16,3	18,4	20,4
Exhaust gas temperature Max.	°C	514	543	517	574
Cooling fan air flow (200 kPa external restriction)	m ³ /min	165,6	165,6	225,6	225,6
Overall thermal efficiency nett	%	39,5	39,6	36,9	36,9
Typical GenSet electrical output (0,8pf @ 25 °C)	kWe	81,4	89,6	91,5	101,2
	kVA	101,4	111,9	114,4	126,5
Assumed alternator efficiency	%	90		90	
Energy balance					
Energy in fuel	kWt	228,1	251	275,2	304,4
Energy to power output (gross)	kWb	93,6	103,0	106,8	117,5
Energy to cooling fan	kWm	3,5		5,1	
Energy to power output (nett)	kWm	90,1	99,5	101,7	112,4
Energy to coolant and lubricating oil	kWt	46,1	50,7	57,7	64,0
Energy to exhaust	kWt	71,7	78,9	89,8	99,7
Energy to radiation	kWt	6,8	7,5	8,5	9,4
Energy to charge cooler	kWt	9,9	10,9	12,4	13,8

Caution: The airflows shown in this table will provide acceptable cooling for an open power unit operating in ambient temperatures of up to 53 °C or 46 °C. If a canopy is fitted. If the power unit is to be enclosed totally, a cooling test should be done to check that the engine cooling is acceptable. If there is insufficient cooling, contact Perkins Technical Service Department.

Performance

Note: All data based on operation to ISO/TR14396, ISO3046/1 standard reference conditions.

All ratings certified to within ... ±5%
 Speed variation at constant load ... ± 0.5%

Cyclic irregularity at rated power

-with 1,31 kgm² flywheel (1500 rev/min) ... 0,029
 -with 1,31 kgm² flywheel (1800 rev/min) ... 0,017

Test conditions

-air temperature ... 25 °C
 -barometric pressure ... 100 kPa
 -relative humidity ... 30%

Sound level

Estimated sound power level for bare engine
 without inlet and exhaust at 1 metre (1500 rev/min) ... 101 dB(A)
 without inlet and exhaust at 1 metre (1800 rev/min) ... 104 dB(A)
 If the engine is to operate in ambient conditions other than those of the test conditions, suitable adjustments must be made for these changes.

For full details, contact Perkins Technical Service Department.

Emissions capability: Certified against the requirements of EU2007 legislation for non-road mobile machinery, powered by constant speed engines (EU97/68/EC Stage II).

1104-44TAG2 ElectropaK, left side view

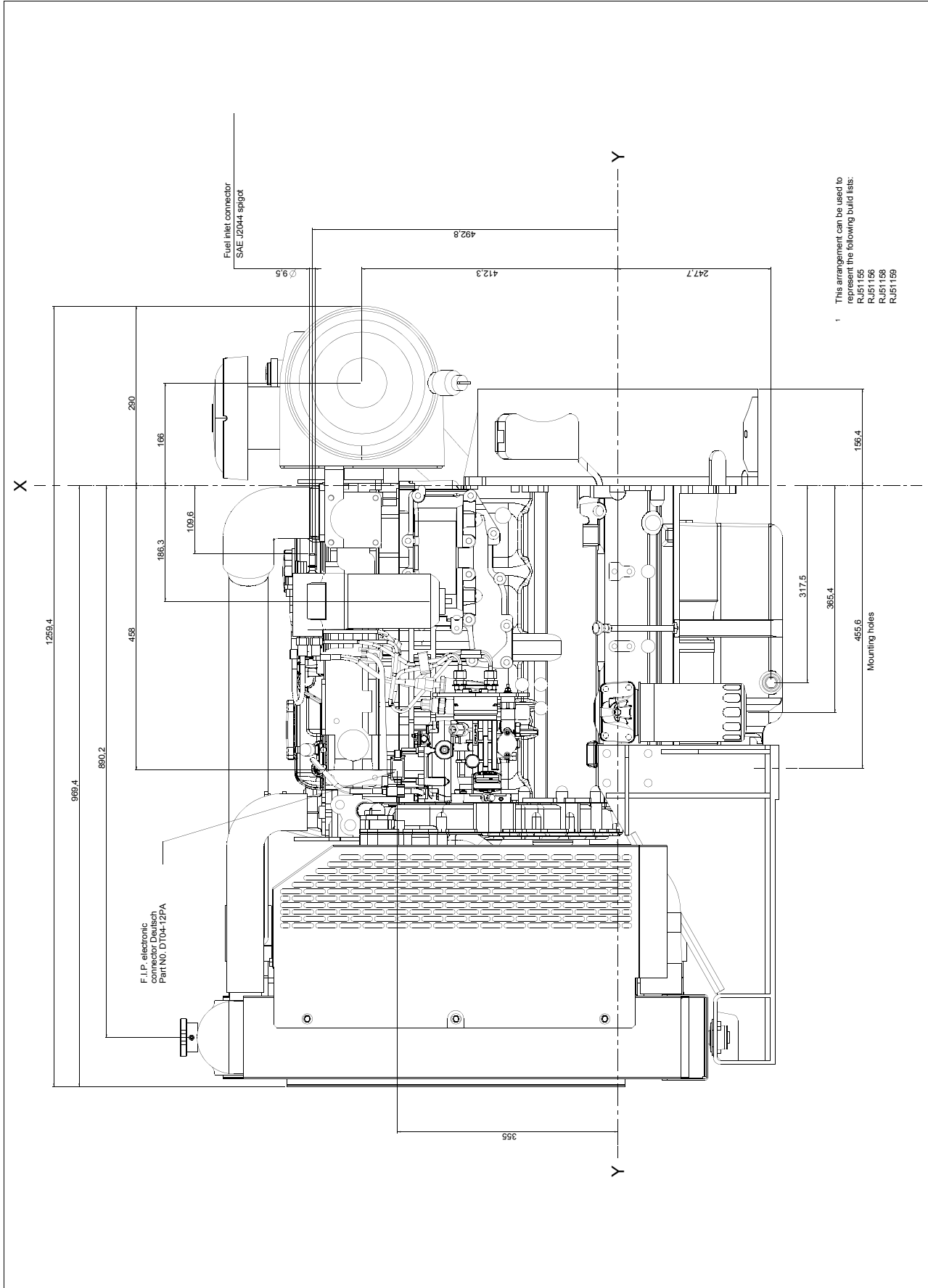

1104C-TAG2 ElectropaK, front view

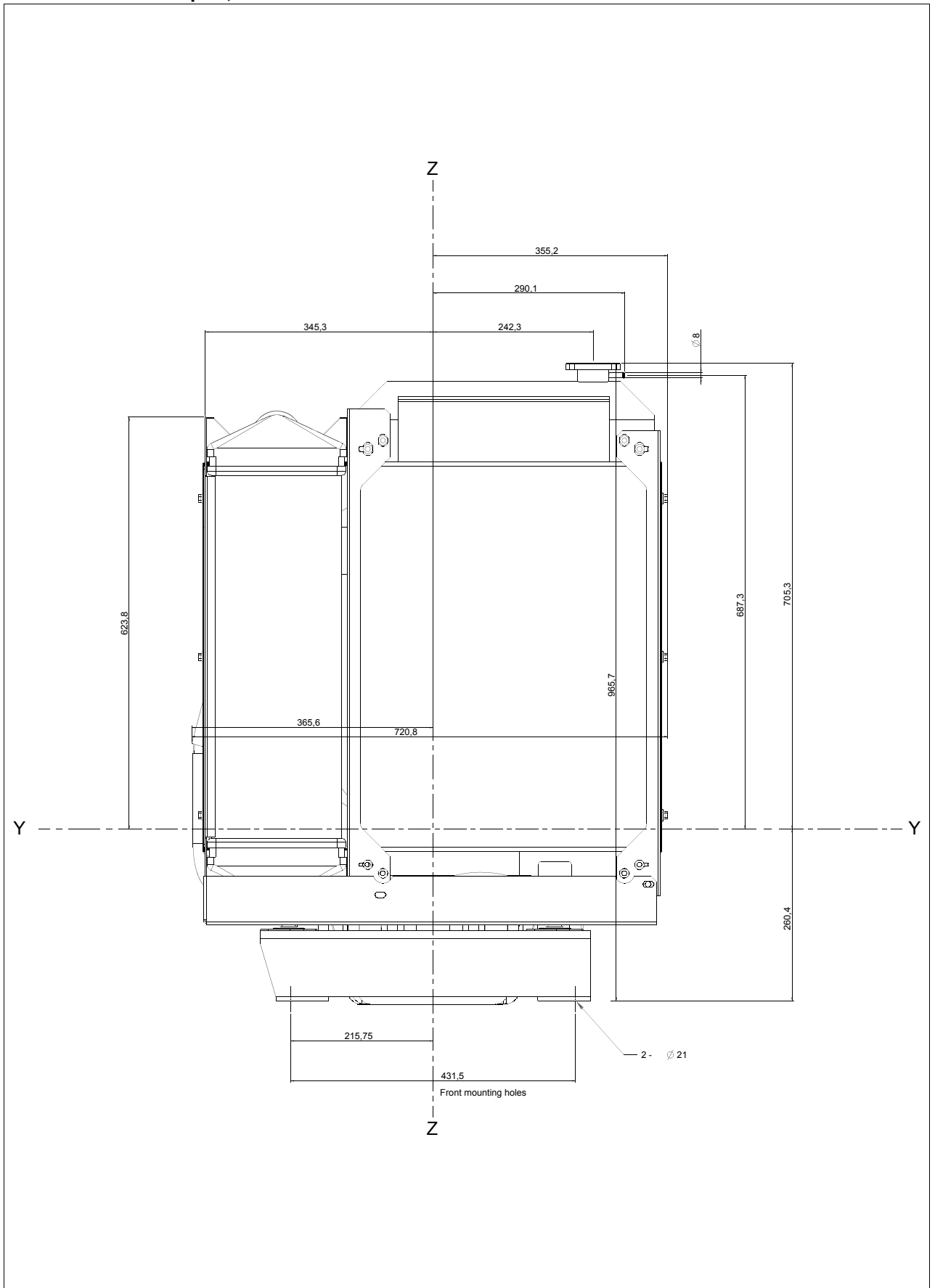

1104-44C TAG2 ElectropaK, right side view

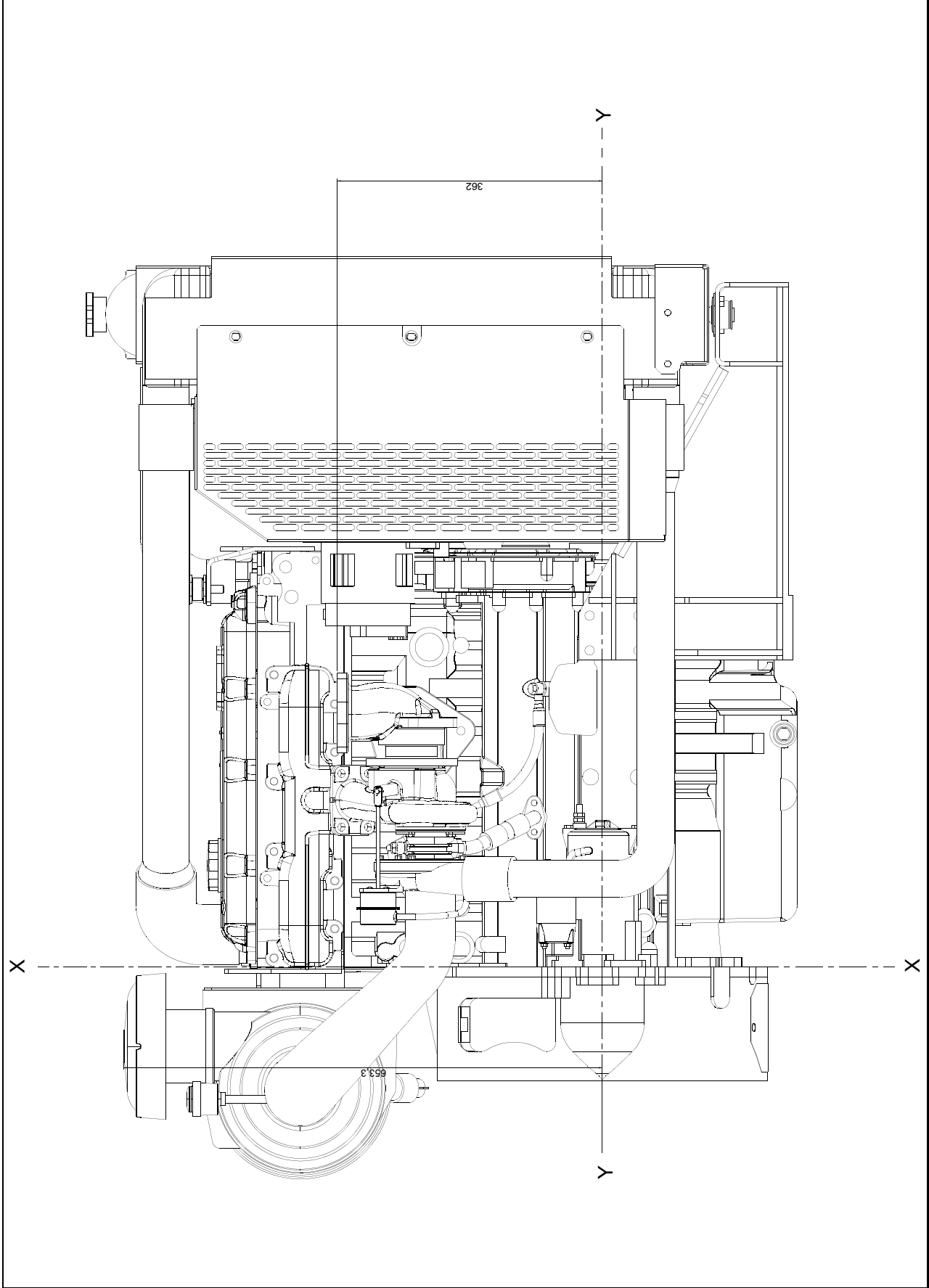

1104C-44TAG2 ElectropaK, rear view

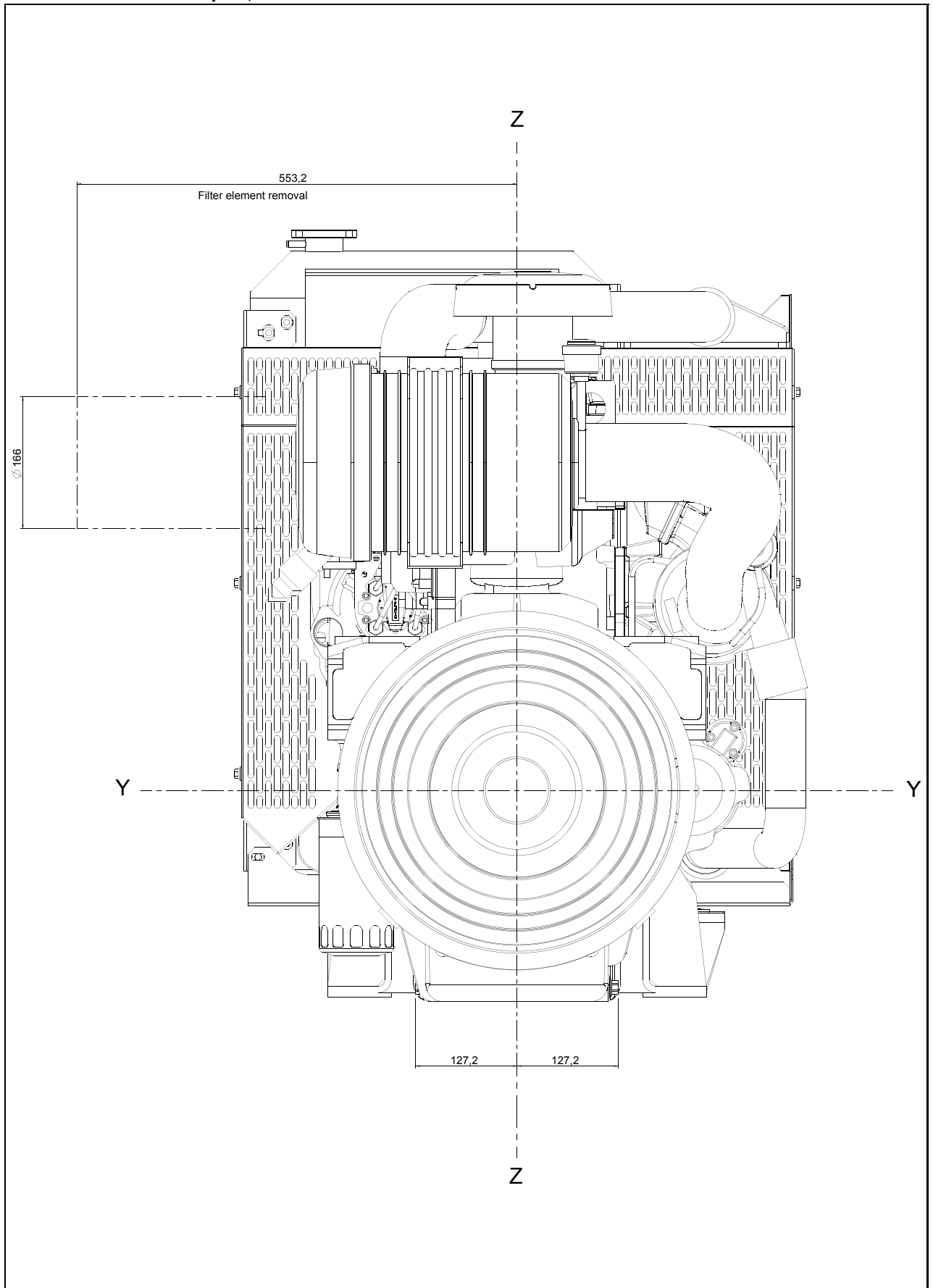

1104C-44TAG2 Electropak, plan view

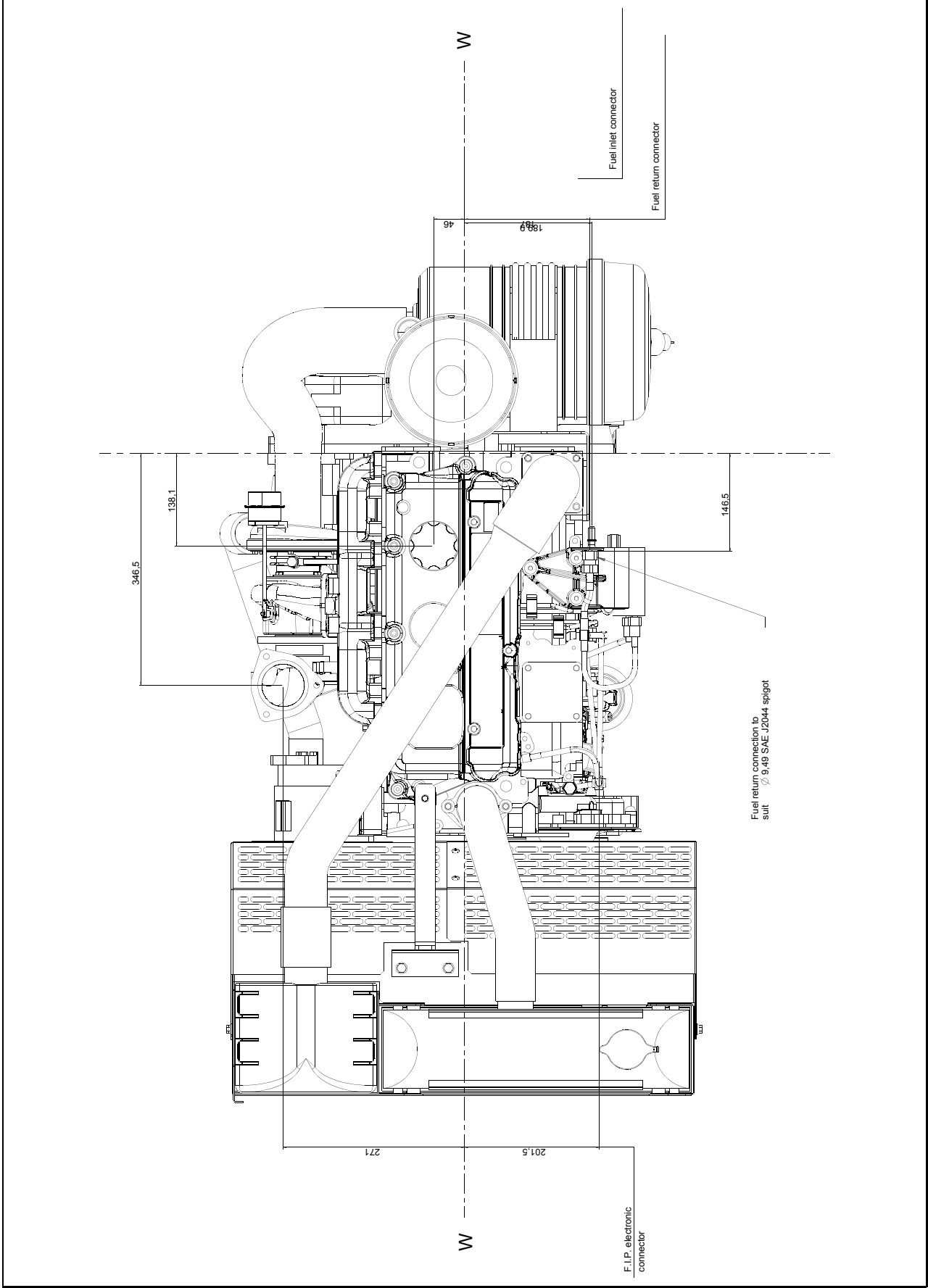

Cooling system

Radiator

-face area	0,25 m ²
-rows and materials.....	38 aluminium
-matrix density and material	9.4 aluminium fins per inch
-width of matrix	439 mm
-height of matrix	570 mm
-pressure cap setting	100 kPa

Fan

-diameter	559 mm
-drive ratio	1:1
-number of blades	10
-material	composite
-type	pusher

Coolant

Total system capacity	
-with radiator	12,6 litres
-without radiator	7,0 litres
Maximum top tank temperature	110 °C
Thermostat operation range.....	82 - 93 °C
Recommended coolant:	
50% ethylene glycol with a corrosion inhibitor (BS 658 :1992 or MOD AL39) and 50% clean fresh water.	

Electrical System

-type	Negative ground
-alternator.....	12V/24V options
-starter motor	12V/24V options

Cold start recommendations

Minimum cranking speed	80 rev/min
------------------------------	------------

Starter motor specifications

Starter motor type	Minimum starting temperature	Minimum battery type for SAE lubricating oil viscosity			
		15W	10W	5W	0W
12 volt, 3.0 kW	°C				
	-5	1 X B			
	-15	1 X B			
	-20		1 X B		
	-25				1 X B

Battery selection

Commercial ref. number	Perkins code	Battery minimum performance	
		BS 3911	SAE J537
643	A	440	660
647	B	510	770
069	D	340	540
655	E	570	810

Exhaust system

Maximum back pressure @ 1500 rev/min.....	18 kPa
Maximum back pressure @ 1800 rev/min.....	15 kPa
Exhaust outlet size	64 mm

Induction system Starter motor specifications

Maximum air intake restriction

-clean filter.....	5 kPa
-dirty filter	8 kPa
-air filter type.....	2 stage cyclonic/paper element

Fuel system

Type of injection	direct
Fuel injection pump	rotary
Fuel atomiser.....	multi-hole
Nozzle opening pressure	29,0 MPa

Fuel lift pump

-flow	120 - 150 litres/hour
-pressure	30 - 75 kPa
Maximum suction head	17 kPa
Maximum static pressure head	10 kPa
Governor type	Perkins LCS electronic governor
Speed control to	ISO 8528, G3

Fuel specification

USA Fed Off Highway EPA2D 89.330-96	
Density (kg/l @ 15°C)	0,835/0855
Viscosity (mm ² /s @ 40 °C)	2,0/4.5
Sulphur content	0.2% Max.
Cetane number.....	45 Min.

Fuel consumption litres/hour

Speed	Power Rating			
	110%	100%	75%	50%
60 Hz	29,7	26,9	20,2	14,1
50 Hz	24,9	22,6	17,1	11,8

Lubrication system

Lubricating oil capacity
 Total system.....8,0 litres
 Sump capacity
 -maximum7 litres
 -minimum5,5 litres

Maximum engine operating angles

-front up, front down, right side or left side.30°

Lubricating oil pressure

-relief valve opens.....415 - 470 kPa
 -at maximum no-load speed276 - 414 kPa
 Normal oil temperature 100 °C
 Max. continuous oil temperature 125 °C
 Oil consumption at full load as a % of fuel consumption 0.15%

Recommended SAE viscosity

A single or multigrade oil must be used which conforms to API-CC/SE or CCMC-D1, see illustration below:

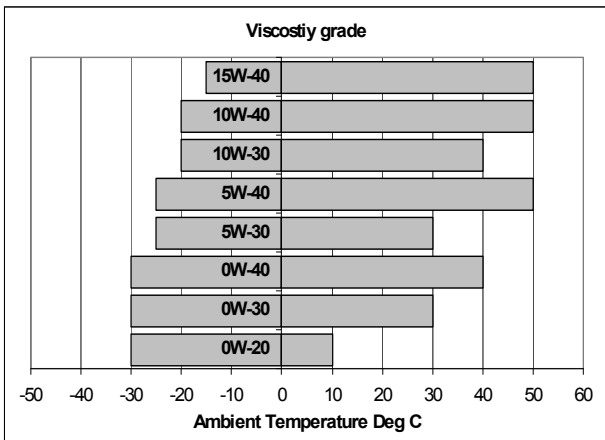

Mountings

Maximum static bending moment
 at rear face of block 791 Nm

@ Perkins

Perkins Engines Company Limited
 Peterborough PE1 5NA United Kingdom
 Telephone +44 (0) 1733 583000
 Fax +44 (0) 1733 582240
 www.perkins.com

Distributed by

All information in the document is substantially correct at the time of printing but may be subsequently altered by the company.

UCI274C - Technical Data Sheet

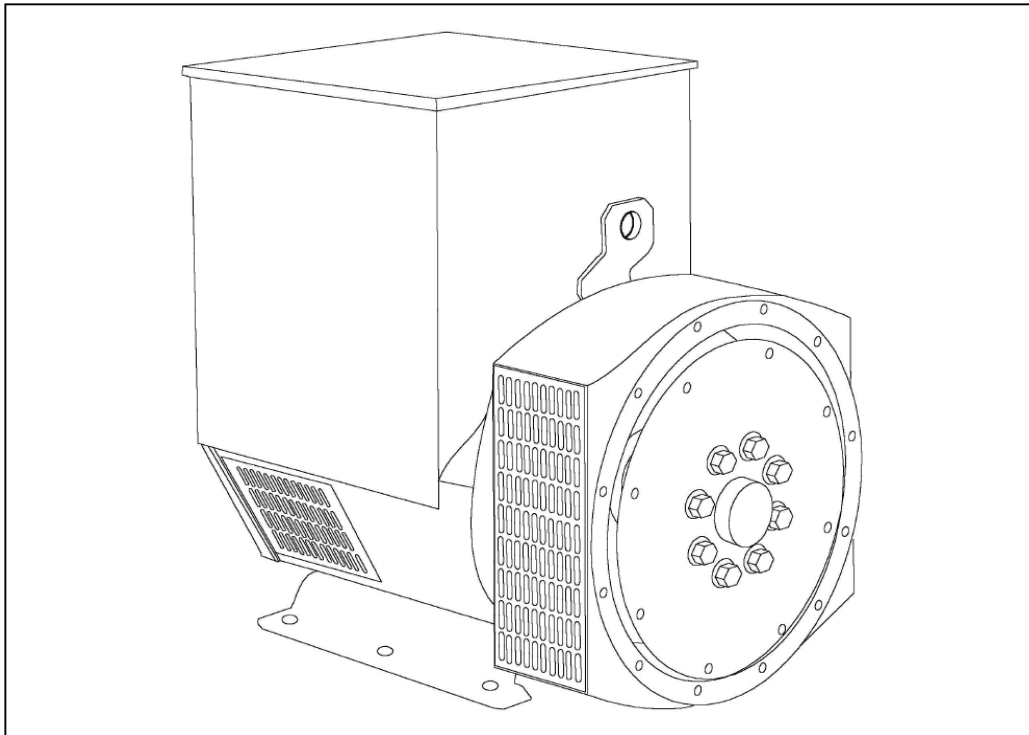

UCI274C

SPECIFICATIONS & OPTIONS



STANDARDS

Newage Stamford industrial generators meet the requirements of BS EN 60034 and the relevant section of other international standards such as BS5000, VDE 0530, NEMA MG1-32, IEC34, CSA C22.2-100, AS1359. Other standards and certifications can be considered on request.

VOLTAGE REGULATORS

SX460 AVR - STANDARD

With this self excited control system the main stator supplies power via the Automatic Voltage Regulator (AVR) to the exciter stator. The high efficiency semiconductors of the AVR ensure positive build-up from initial low levels of residual voltage.

The exciter rotor output is fed to the main rotor through a three phase full wave bridge rectifier. This rectifier is protected by a surge suppressor against surges caused, for example, by short circuit.

SX440 AVR

With this self-excited system the main stator provides power via the AVR to the exciter stator. The high efficiency semi-conductors of the AVR ensure positive build-up from initial low levels of residual voltage.

The exciter rotor output is fed to the main rotor through a three-phase full-wave bridge rectifier. The rectifier is protected by a surge suppressor against surges caused, for example, by short circuit or out-of-phase paralleling.

The SX440 will support a range of electronic accessories, including a 'droop' Current Transformer (CT) to permit parallel operation with other ac generators.

If 3-phase sensing is required with the self-excited system, the SX421 AVR must be used.

SX421AVR

This AVR also operates in a self-excited system. It combines all the features of the SX440 with, additionally, three-phase rms sensing for improved regulation and performance. Over voltage protection is provided via a separate circuit breaker. An engine relief load acceptance feature is built in as standard.

MX341 AVR

This sophisticated AVR is incorporated into the Stamford Permanent Magnet Generator (PMG) control system.

The PMG provides power via the AVR to the main exciter, giving a source of constant excitation power independent of generator output. The main exciter output is then fed to the main rotor, through a full wave bridge, protected by a surge suppressor. The AVR has in-built protection against sustained over-excitation, caused by internal or external faults. This de-excites the machine after a minimum of 5 seconds.

An engine relief load acceptance feature can enable full load to be applied to the generator in a single step.

If three-phase sensing is required with the PMG system the MX321 AVR must be used.

We recommend three-phase sensing for applications with greatly unbalanced or highly non-linear loads.

MX321 AVR

The most sophisticated of all our AVRs combines all the features of the MX341 with, additionally, three-phase rms sensing, for improved regulation and performance.

Over voltage protection is built-in and short circuit current level adjustments is an optional facility.

WINDINGS & ELECTRICAL PERFORMANCE

All generator stators are wound to 2/3 pitch. This eliminates triplen (3rd, 9th, 15th ...) harmonics on the voltage waveform and is found to be the optimum design for trouble-free supply of non-linear loads. The 2/3 pitch design avoids excessive neutral currents sometimes seen with higher winding pitches, when in parallel with the mains. A fully connected damper winding reduces oscillations during paralleling. This winding, with the 2/3 pitch and carefully selected pole and tooth designs, ensures very low waveform distortion.

TERMINALS & TERMINAL BOX

Standard generators are 3-phase reconnectable with 12 ends brought out to the terminals, which are mounted on a cover at the non-drive end of the generator. A sheet steel terminal box contains the AVR and provides ample space for the customers' wiring and gland arrangements. It has removable panels for easy access.

SHAFT & KEYS

All generator rotors are dynamically balanced to better than BS6861:Part 1 Grade 2.5 for minimum vibration in operation. Two bearing generators are balanced with a half key.

INSULATION/IMPREGNATION

The insulation system is class 'H'.

All wound components are impregnated with materials and processes designed specifically to provide the high build required for static windings and the high mechanical strength required for rotating components.

QUALITY ASSURANCE

Generators are manufactured using production procedures having a quality assurance level to BS EN ISO 9001.

The stated voltage regulation may not be maintained in the presence of certain radio transmitted signals. Any change in performance will fall within the limits of Criteria 'B' of EN 61000-6-2:2001. At no time will the steady-state voltage regulation exceed 2%.

NB Continuous development of our products entitles us to change specification details without notice, therefore they must not be regarded as binding.

UCI274C WINDING 311

CONTROL SYSTEM		SEPARATELY EXCITED BY P.M.G.							
A.V.R.		MX321	MX341						
VOLTAGE REGULATION		± 0.5 %	± 1.0 %	With 4% ENGINE GOVERNING					
SUSTAINED SHORT CIRCUIT		REFER TO SHORT CIRCUIT DECREMENT CURVES (page 7)							
CONTROL SYSTEM		SELF EXCITED							
A.V.R.		SX460	SX440	SX421					
VOLTAGE REGULATION		± 1.5 %	± 1.0 %	± 0.5 %	With 4% ENGINE GOVERNING				
SUSTAINED SHORT CIRCUIT		SERIES 4 CONTROL DOES NOT SUSTAIN A SHORT CIRCUIT CURRENT							
INSULATION SYSTEM		CLASS H							
PROTECTION		IP23							
RATED POWER FACTOR		0.8							
STATOR WINDING		DOUBLE LAYER CONCENTRIC							
WINDING PITCH		TWO THIRDS							
WINDING LEADS		12							
STATOR WDG. RESISTANCE		0.059 Ohms PER PHASE AT 22°C SERIES STAR CONNECTED							
ROTOR WDG. RESISTANCE		1.12 Ohms at 22°C							
R.F.I. SUPPRESSION		BS EN 61000-6-2 & BS EN 61000-6-4,VDE 0875G, VDE 0875N. refer to factory for others							
WAVEFORM DISTORTION		NO LOAD < 1.5% NON-DISTORTING BALANCED LINEAR LOAD < 5.0%							
MAXIMUM OVERSPEED		2250 Rev/Min							
BEARING DRIVE END		BALL. 6315-2RS (ISO)							
BEARING NON-DRIVE END		BALL. 6310-2RS (ISO)							
		1 BEARING				2 BEARING			
WEIGHT COMP. GENERATOR		406 kg				420 kg			
WEIGHT WOUND STATOR		131 kg				131 kg			
WEIGHT WOUND ROTOR		133.78 kg				122.82 kg			
WR ² INERTIA		1.0288 kgm ²				0.9781 kgm ²			
SHIPPING WEIGHTS in a crate		439 kg				452 kg			
PACKING CRATE SIZE		105 x 67 x 103(cm)				105 x 67 x 103(cm)			
		50 Hz				60 Hz			
TELEPHONE INTERFERENCE		THF<2%				TIF<50			
COOLING AIR		0.514 m ³ /sec 1090 cfm				0.617 m ³ /sec 1308 cfm			
VOLTAGE SERIES STAR		380/220	400/231	415/240	440/254	416/240	440/254	460/266	480/277
VOLTAGE PARALLEL STAR		190/110	200/115	208/120	220/127	208/120	220/127	230/133	240/138
VOLTAGE SERIES DELTA		220/110	230/115	240/120	254/127	240/120	254/127	266/133	277/138
KVA BASE RATING FOR REACTANCE VALUES		100	100	100	n/a	112.5	117.5	117.5	125
Xd DIR. AXIS SYNCHRONOUS		2.45	2.21	2.05	-	2.76	2.58	2.36	2.30
X'd DIR. AXIS TRANSIENT		0.20	0.18	0.17	-	0.24	0.22	0.21	0.20
X''d DIR. AXIS SUBTRANSIENT		0.14	0.13	0.12	-	0.16	0.15	0.14	0.13
Xq QUAD. AXIS REACTANCE		1.59	1.43	1.33	-	1.58	1.48	1.35	1.32
X''q QUAD. AXIS SUBTRANSIENT		0.18	0.16	0.15	-	0.23	0.21	0.20	0.19
Xl LEAKAGE REACTANCE		0.07	0.06	0.06	-	0.08	0.07	0.07	0.07
X2 NEGATIVE SEQUENCE		0.16	0.14	0.13	-	0.19	0.18	0.16	0.16
X0 ZERO SEQUENCE		0.10	0.09	0.08	-	0.12	0.11	0.10	0.10
REACTANCES ARE SATURATED				VALUES ARE PER UNIT AT RATING AND VOLTAGE INDICATED					
T'd TRANSIENT TIME CONST.		0.028 s							
T''d SUB-TRANSTIME CONST.		0.001 s							
T'do O.C. FIELD TIME CONST.		0.8 s							
Ta ARMATURE TIME CONST.		0.007 s							
SHORT CIRCUIT RATIO		1/Xd							

**50
Hz**

UCI274C
Winding 311



THREE PHASE EFFICIENCY CURVES

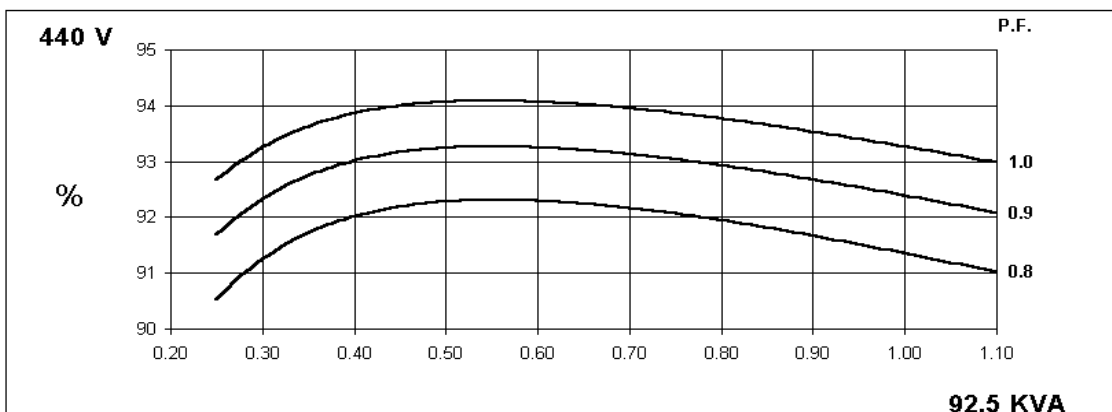
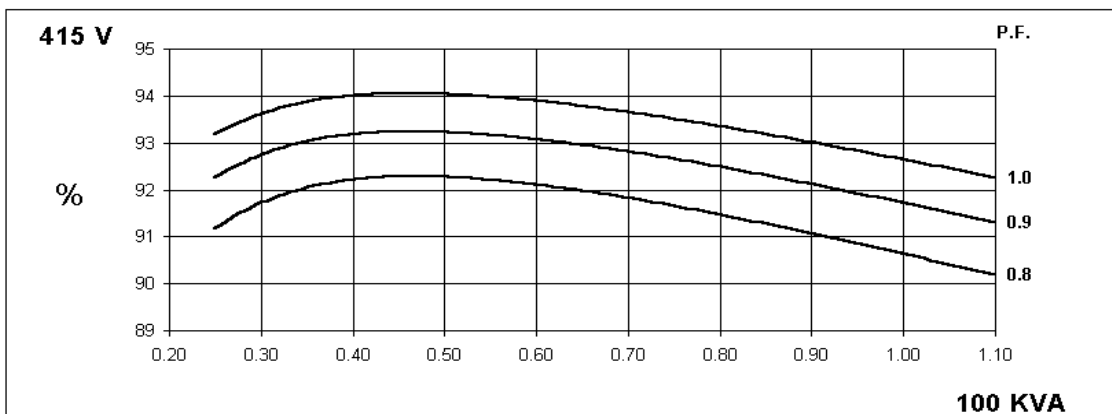
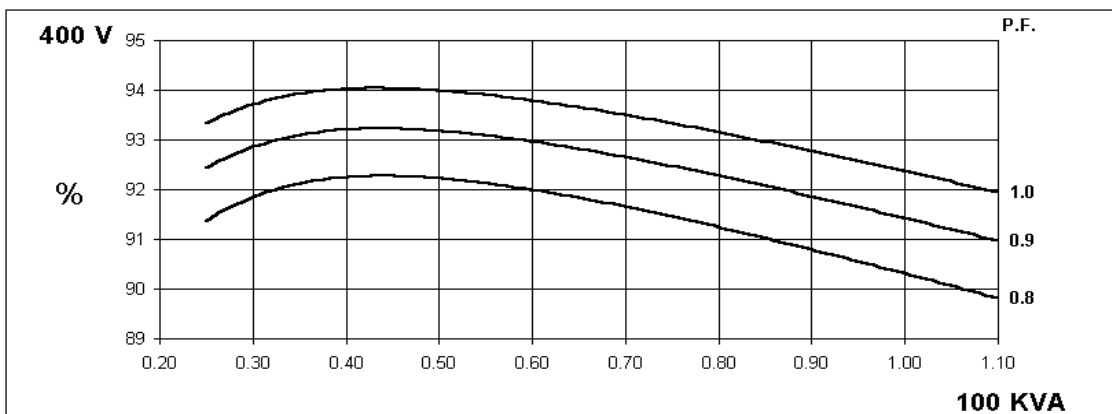
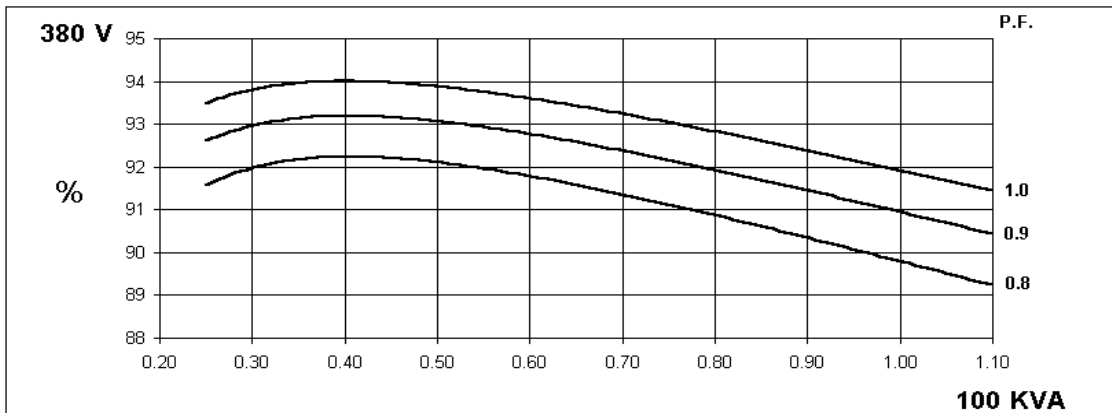

THREE PHASE EFFICIENCY CURVES

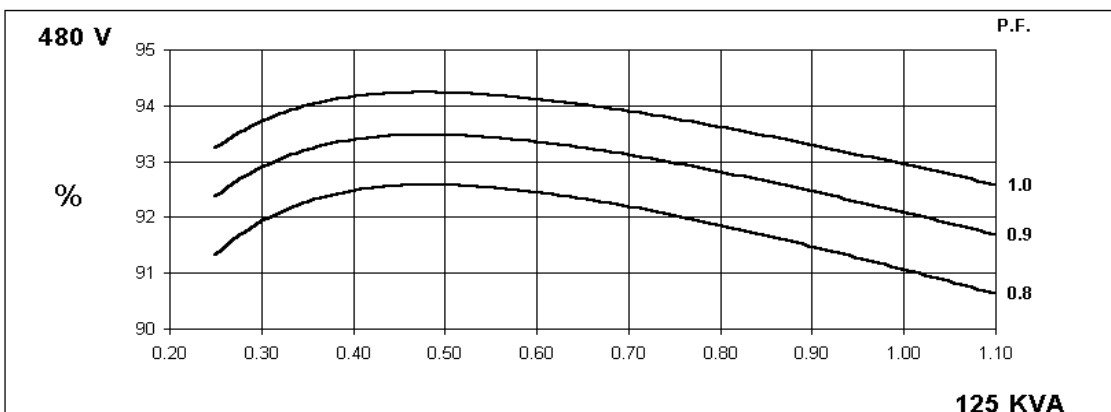
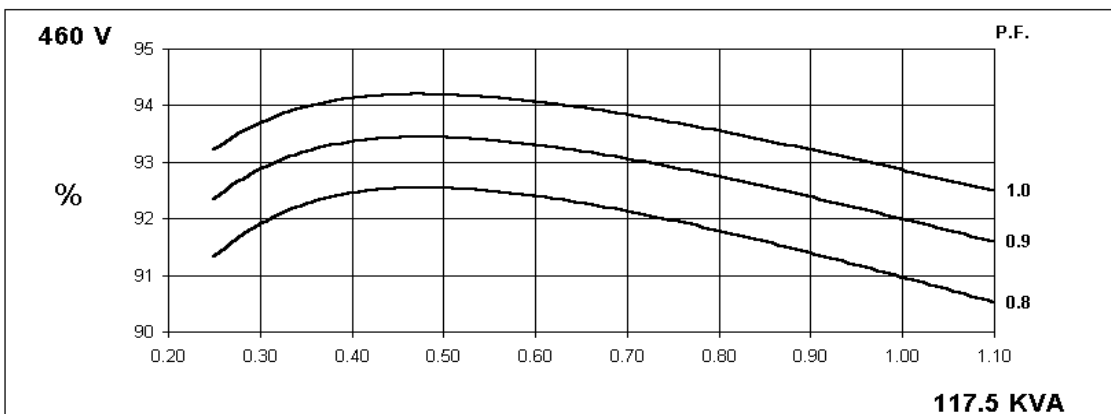
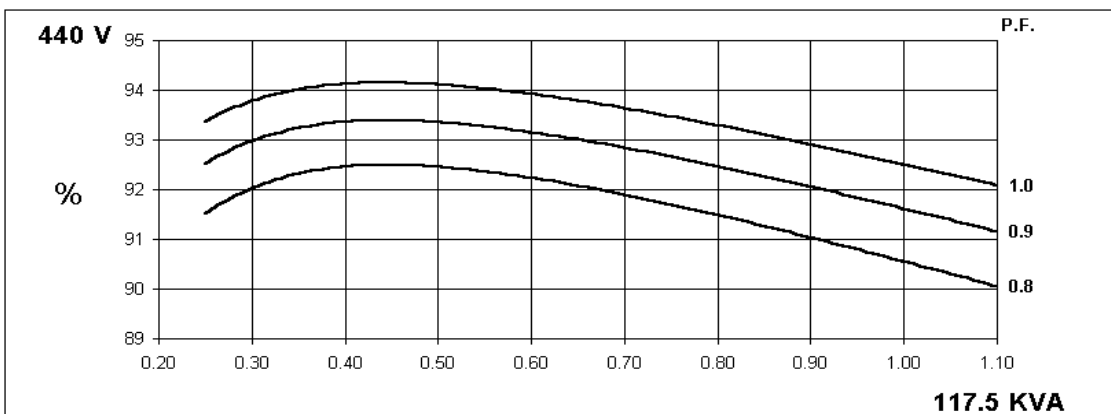
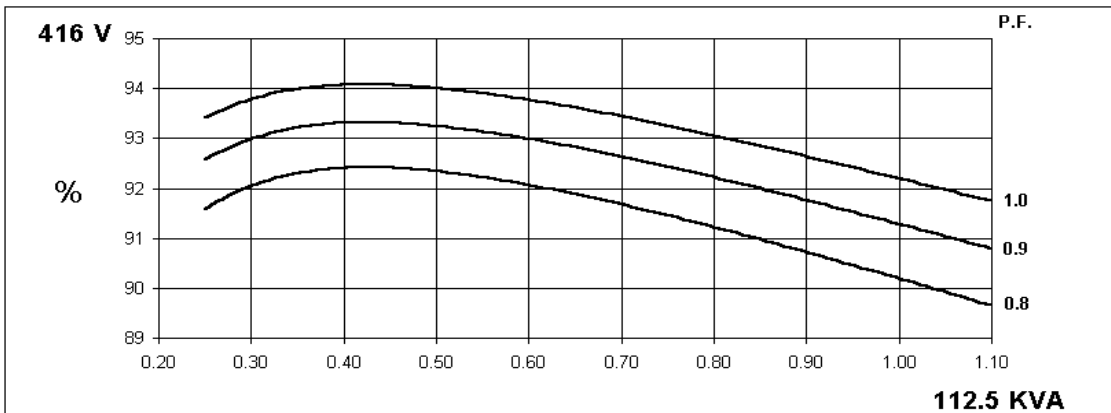

UCI274C

Winding 311



Locked Rotor Motor Starting Curve

**50
Hz**

MX

SX

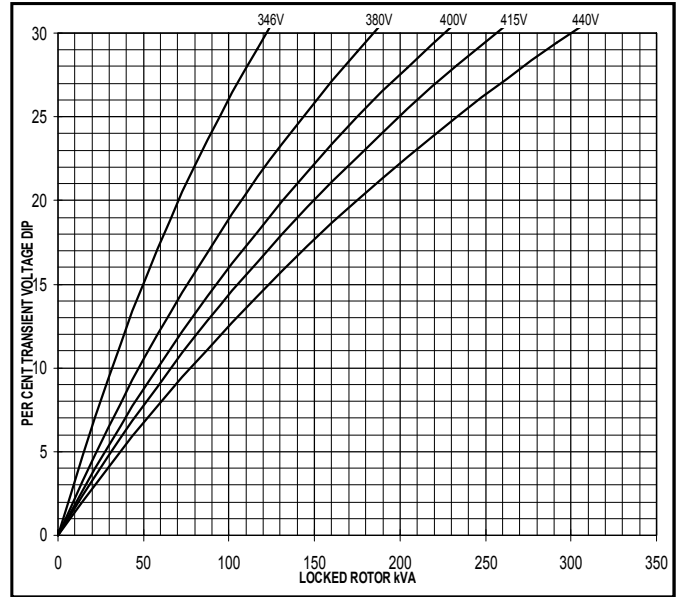
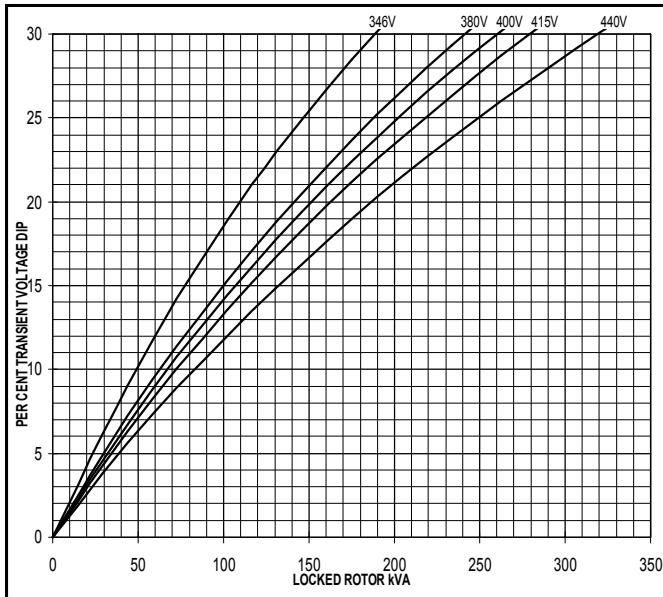

**60
Hz**

MX

SX

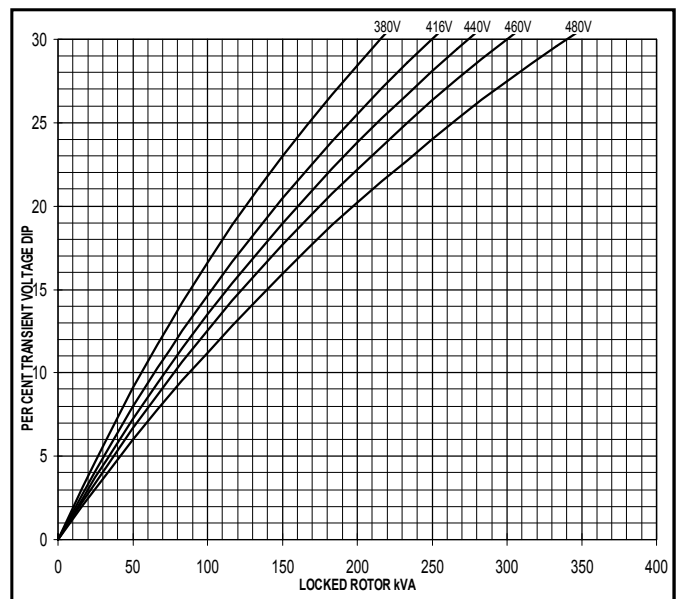
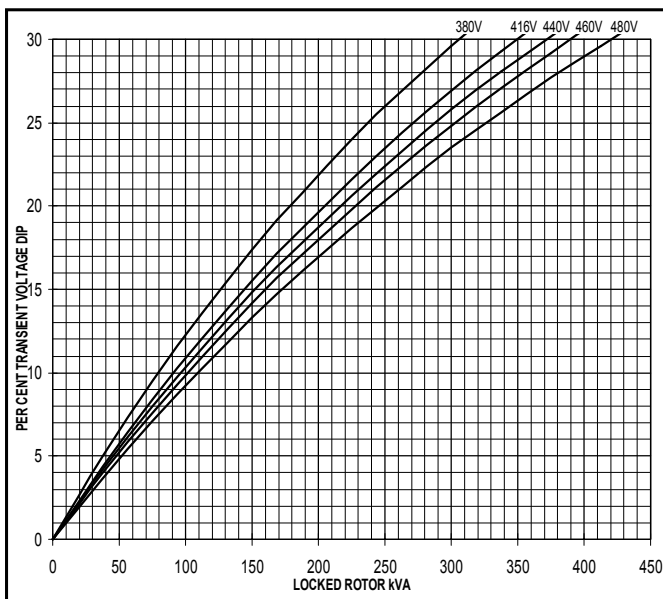

**Three-phase Short Circuit Decrement Curve. No-load Excitation at Rated Speed
Based on star (wye) connection.**

**50
Hz**

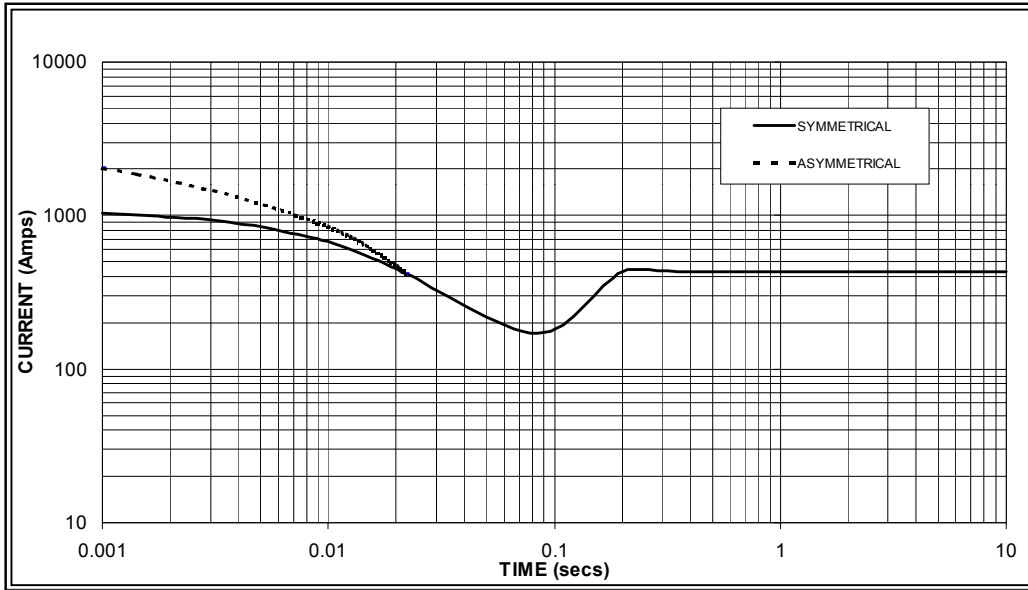

Sustained Short Circuit = 430 Amps

**60
Hz**

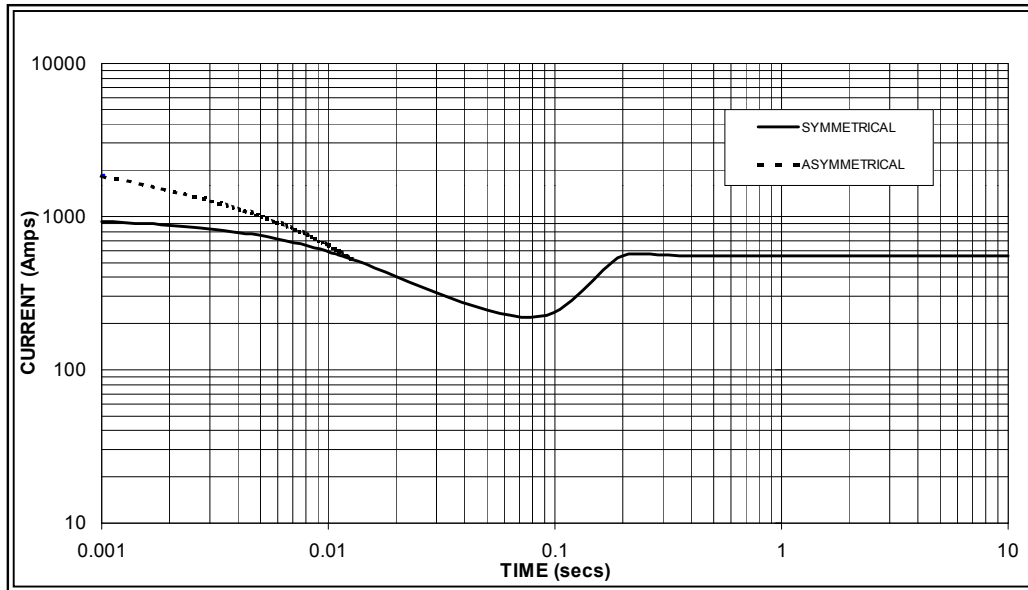

Sustained Short Circuit = 550 Amps

Note 1

The following multiplication factors should be used to adjust the values from curve between time 0.001 seconds and the minimum current point in respect of nominal operating voltage :

50Hz		60Hz	
Voltage	Factor	Voltage	Factor
380v	X 1.00	416v	X 1.00
400v	X 1.07	440v	X 1.06
415v	X 1.12	460v	X 1.12
440v	X 1.18	480v	X 1.17

The sustained current value is constant irrespective of voltage level

Note 2

The following multiplication factor should be used to convert the values calculated in accordance with NOTE 1 to those applicable to the various types of short circuit :

	3-phase	2-phase L-L	1-phase L-N
Instantaneous	x 1.00	x 0.87	x 1.30
Minimum	x 1.00	x 1.80	x 3.20
Sustained	x 1.00	x 1.50	x 2.50
Max. sustained duration	10 sec.	5 sec.	2 sec.

All other times are unchanged

Note 3

Curves are drawn for Star (Wye) connected machines. For other connection the following multipliers should be applied to current values as shown :

Parallel Star = Curve current value X 2

Series Delta = Curve current value X 1.732

UCI274C

Winding 311 / 0.8 Power Factor



RATINGS

Class - Temp Rise		Cont. F - 105/40°C				Cont. H - 125/40°C				Standby - 150/40°C				Standby - 163/27°C			
50 Hz	Series Star (V)	380	400	415	440	380	400	415	440	380	400	415	440	380	400	415	440
	Parallel Star (V)	190	200	208	220	190	200	208	220	190	200	208	220	190	200	208	220
	Series Delta (V)	220	230	240	254	220	230	240	254	220	230	240	254	220	230	240	254
	kVA	84.0	84.0	84.0	n/a	100.0	100.0	100.0	n/a	106.0	106.0	106.0	n/a	110.0	110.0	110.0	n/a
	kW	67.2	67.2	67.2	n/a	80.0	80.0	80.0	n/a	84.8	84.8	84.8	n/a	88.0	88.0	88.0	n/a
	Efficiency (%)	90.7	91.1	91.3	n/a	89.8	90.3	90.6	n/a	89.5	90.0	90.4	n/a	89.2	89.8	90.2	n/a
	kW Input	74.1	73.8	73.6	n/a	89.1	88.6	88.3	n/a	94.7	94.2	93.8	n/a	98.7	98.0	97.6	n/a
60 Hz	Series Star (V)	416	440	460	480	416	440	460	480	416	440	460	480	416	440	460	480
	Parallel Star (V)	208	220	230	240	208	220	230	240	208	220	230	240	208	220	230	240
	Series Delta (V)	240	254	266	277	240	254	266	277	240	254	266	277	240	254	266	277
	kVA	97.5	106.3	106.3	112.5	112.5	117.5	117.5	125.0	116.3	125.0	125.0	132.5	120.0	127.5	127.5	137.5
	kW	78.0	85.0	85.0	90.0	90.0	94.0	94.0	100.0	93.0	100.0	100.0	106.0	96.0	102.0	102.0	110.0
	Efficiency (%)	90.9	91.0	91.4	91.5	90.2	90.6	91.0	91.1	90.0	90.2	90.7	90.8	89.8	90.1	90.6	90.6
	kW Input	85.8	93.5	93.0	98.4	99.8	103.8	103.3	109.8	103.4	110.9	110.3	116.7	106.9	113.2	112.6	121.4

DIMENSIONS

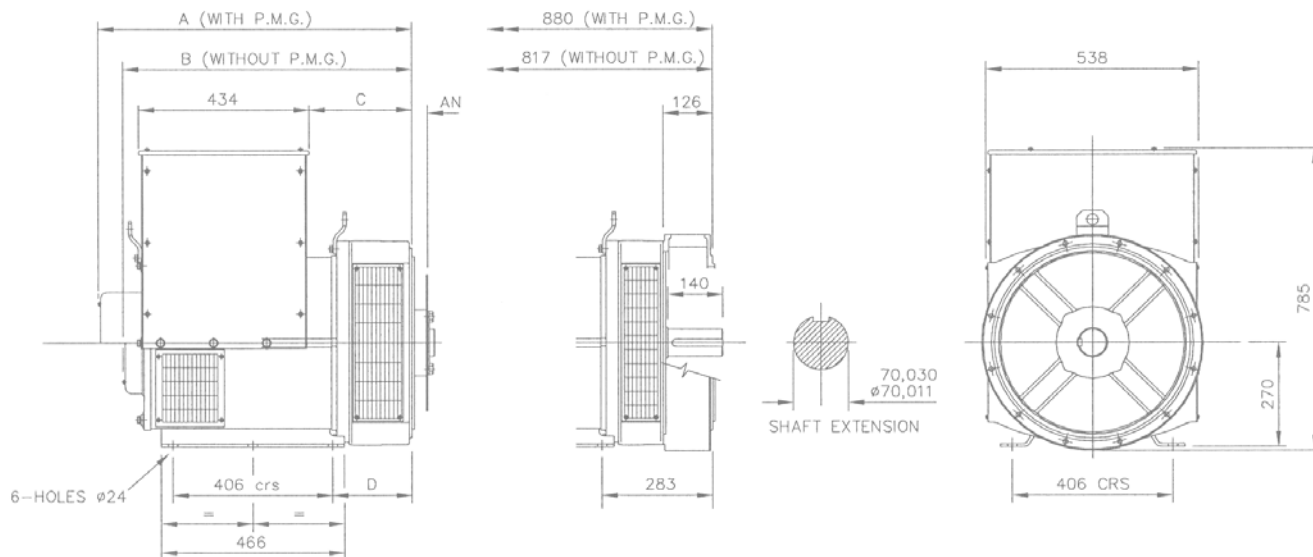

SINGLE BEARING ADAPTORS				
ADAPTOR	A	B	C	D
SAE 1	813,3	750,3	274,3	216,3
SAE 2	799	736	260	202
SAE 3	799	736	260	202

COUPLING DISCS	
DISC	AN
SAE 10	53,98
SAE 11,5	39,68
SAE 14	25,40



PO Box 17 • Barnack Road • Stamford • Lincolnshire • PE9 2NB

Tel: 00 44 (0)1780 484000 • Fax: 00 44 (0)1780 484100

Website: www.newage-avkseg.com