



ottomotores

Mitsubishi Series S12R

Energía que Mueve al Mundo

MNY1250

Potencia Standby

Aplicable para suministro de energía en emergencia con carga variable con duración mientras este interrumpido la red comercial (en acorde a norma ISO8528).

Potencia Prime

Clasificación corresponde a la norma ISO de energía para funcionamiento continuo.

Es aplicable para el suministro de energía eléctrica a carga variable durante un número ilimitado de horas en lugar de red eléctrica comercial una sobrecarga de 10% está disponible para esta calificación.

Modelo	Voltaje	Prime kVA	Prime kW	Stand-by kVA	Stand-by kW
MNY1250	220-440V	1468	1135	1562	1250

0.8 Factor de potencia

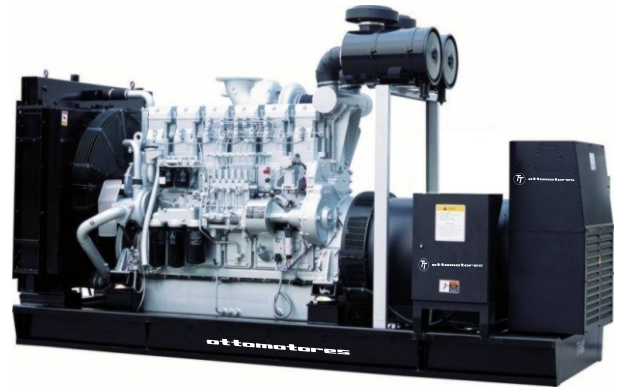

Nota: Imagen de carácter ilustrativa ya que los equipos en foto pudieran incluir accesorios opcionales

Datos Técnicos	
Motor:	S16R-Y1PTA-1
Generador:	HCI634K
Numero de Cilindros:	12 Cilindros en "V"
Diámetro por Carrera: in (mm)	6.69 x 7.09 (170 x 180)
Relación de Compresión::	15.0:1
Aspiración:	Turbocargado / Post-Enfriador
Frecuencia:	60 Hz
Velocidad de Motor:	1800 rpm
Potencia Maxima: BHP(kWm)	1881 (1403)
BMEP: psi (kgf/cm²)	276 (19.4)
Velocidad de Piston: ft/min (m/s)	2126 (10.8)
Consumo: lt / hr - 100% carga	312,00
Rechazo de Calor en sistema: BTU/min (kcal/hr)	70941 (1072611)
Rechazo de Calor en sistema Radiator BTU/min (kcal/hr)	52336 (791303)
Enfriamiento Flujo de aire: m³/seg - CFM	1800 (63558)
Flujo de Escape: cfm	11794 (334)



Como leer nuestro código: Ejem: CNY1250

M=Motor Mitsubishi
N=Generador Newage Stamford
Y=60Hz-1800 RPM
1250= Potencia del Equipo.



LAPEM

Ottomotores, S.A de C.V.

Calz. San Lorenzo No.1150
Col. Cerro de la estrella, C.P. 09860
Delg. Iztapalapa México, D.F.
Tels:52-55-5624-5600

Fax: 52-55-5426-5521 / 52-55-5426-5581
email : ventas@ottomotores.com.mx

sitio web: www.ottomotores.com.mx

Dimensiones

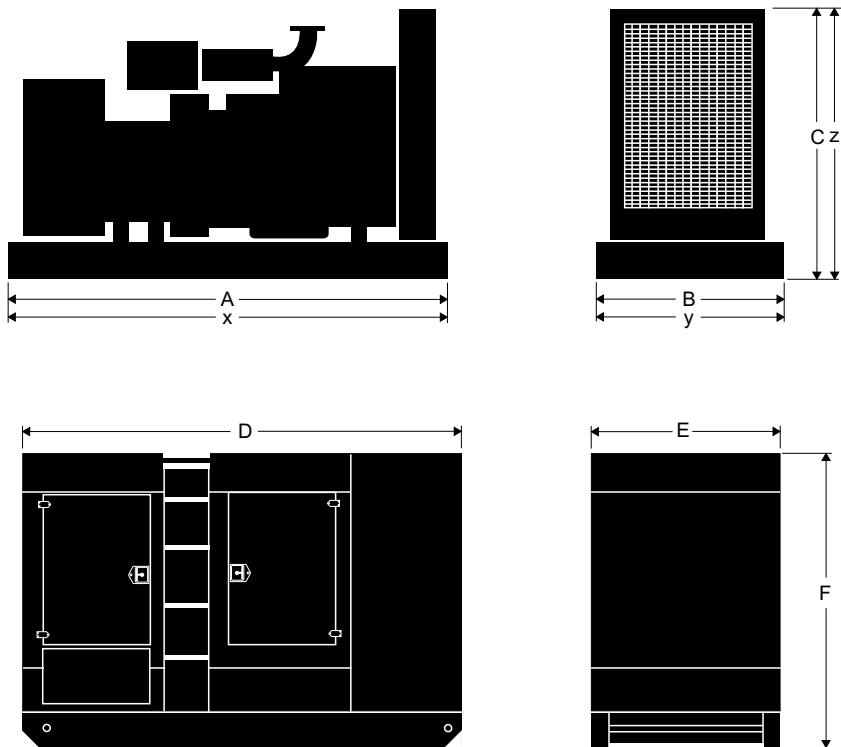

	Equipo con Base Estructural			Equipo con Base Tanque			Equipo con Caseta Acústica*		
	A	B	C	x	y	z	D	E	F
G-drive	528,00	229,00	229,00	Llame a Fabrica			Llame a Fabrica		
	Peso: 8785,00 kgs								

[*] opcional

Información Técnica

Nota: las condiciones de referencia estándar son de 25 °C (77 ° F) temperatura de entrada de aire. Todos los datos de desempeño de motores son basados en la potencia mencionada arriba.

Datos de consumo de combustible a plena carga con combustible diesel tienen una gravedad específica de 0,85.

Comercializado por:

Módulos de Control



Ottomotores tiene una posición única en la fabricación de grupos electrógenos utilizando en ellos módulos de control que cumplen con todos los niveles de requerimiento del mercado nacional y de exportación.



Las diferentes soluciones de controles que se tienen para nuestra gama de plantas generadoras, permite una operación simple en modo manual y automático, así mismo permiten desarrollar proyectos de sincronía entre plantas generadoras o con la red de energía eléctrica.



La familia de módulos de control en transición abierta (DALE 3200) permite tener control en forma automática de la unidad de transferencia, así como el monitoreo del grupo generador.



Nuestro módulos de control cuentan con puerto de comunicación RS485 para la comunicación remota con el grupo generador.



Los módulos pueden ser monitoreados através de un excelente software para observar parámetros del equipo de manera fácil y rápida.



La familia de módulos de control para la sincronía (6100, 6050 y 6300), incorporan un amplio sistema de monitoreos además de conexión a Internet (LAN) o mensaje SMS vía celular, o usando los puertos de comunicación RS485 a través de ModBus



ottomotores

Energía que Mueve al Mundo

Calz. San Lorenzo No.1150
Col. Cerro de la Estrella, C.P.09860
Delegación Iztapalapa México D.F.
Tels: 52-55-5624-5600
Fax.52-55-5426-55-21 / 52-55-54265581

E-mail ventas1@ottomotores.com.mx
ventas2@ottomotores.com.mx

Web site. www.ottomotores.com.mx

© Ottomotores se reserva el derecho de hacer cambios sin previo aviso con el fin de mejorar nuestros productos 2010

MODELS
MNE1430
MNY1250

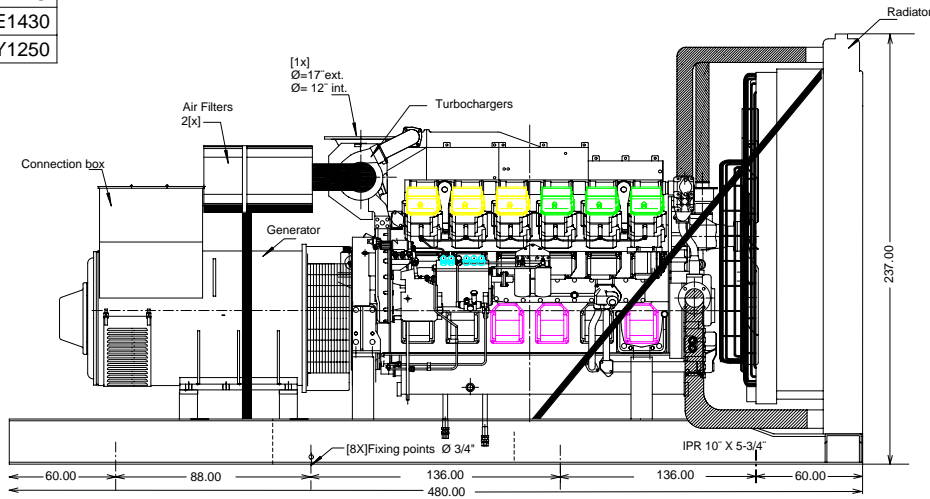

SIDE VIEW

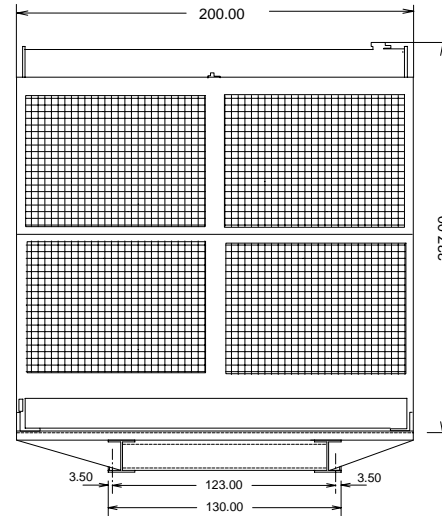

FRONT VIEW

DESCRIPTION	
RADIATOR:	COVRAD 1391
ENGINE:	MITSUBISHI S12R-Y1PTA
GENERATOR:	PI 734 B (50Hz) HC1634K (60Hz)
BASE FRAME:	MIT-02
AVMS's SPRING:	8 PZS
TOTAL WEIGHT:	DRY= 4800.00 kgs WET = 5080.00 kgs

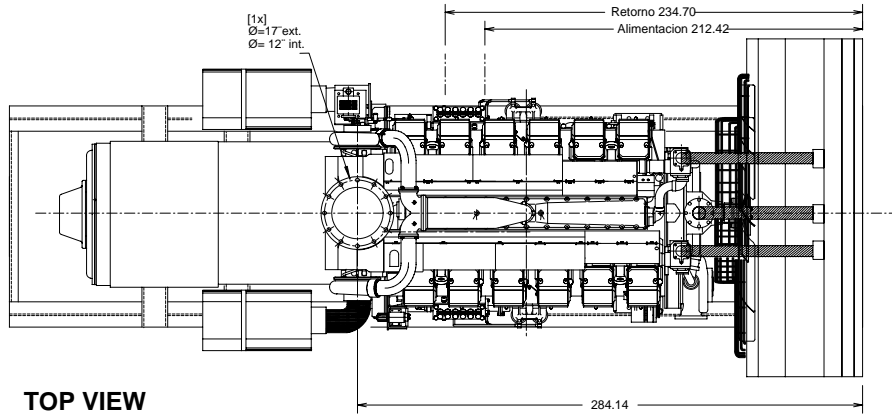

TOP VIEW

Customer: S/O:

Rev.	Description	Date	Certificated

Reviews

Title: **MITSUBISHI ENGINE S12R-Y-1PTA-2 / STAMFORD ALTERNATOR**

Draw: R.G.C.	Revised: O.P.V.	Certificated: V.F.F.	Code: MNE/Y-02
Date: JUL 03th 2008	Date: JUL 03th 2008	Date: JUL 03th 2008	Dept.: Engineering



OT TOMOTORES

Marks: cms Draw:

Scale: s/e Of:



Ottomotores keeps the right to change the information with out prior notice

GENERAL ENGINE DATA

Type	4-Cycle, Water Cooled
Aspiration	Turbo-Charged, After Cooler (Jacket water to Cooler)
Cylinder Arrangement	60°V
No. of Cylinders	12
Bore mm(in.)	170 (6.69)
Stroke mm(in.)	180 (7.09)
Displacement liter(ir ³)	49.03 (2992)
Compression Ratio	15.0:1
Dry Weight - Engine only - kg(lb)	4800 (10584)
Wet Weight - Engine only - kg(lb)	5080 (11201)

PERFORMANCE DATA

Steady State Speed Stability Band at any Constant Load	
Electric Governor - %	±0.25 or better
Maximum Overspeed Capacity - rpr	2100
Moment of inertia of Rotating Components - kg·m ² (lb·ft ²)	75.3 (1787)
(Includes Std. Flywheel)	
Cyclic Speed Variation with Flywheel at 1800rpm	1/565

ENGINE MOUNTING

Maximum Bending Moment at Rear Face of Flywheel Housing - kg·m(lb·ft)	450 (3256)
---	------------

AIR INLET SYSTEM

Maximum Intake Air Restriction (Includes piping)	
With Clean Filter Element - mm H ₂ O (in. H ₂ O)	400 (15.7)
With Dirty Filter Element - mm H ₂ O (in. H ₂ O)	635 (25.0)

EXHAUST SYSTEM

Maximum Allowable Back Pressure - mm H ₂ O (in. H ₂ O)	600 (23.6)
--	------------

LUBRICATION SYSTEM

Oil Pressure at Idle - kgf/cm ² (psi)	2~3 (29~43)
at Rated Speed - kgf/cm ² (psi)	5~6.5 (71~93)
Maximum Oil Temperature - °C(°F)	110 (230)
Oil Capacity of Standard Pan	High - liter (U.S. gal) 150 (39.6)
	Low - liter (U.S. gal) 108 (28.5)
Total System Capacity (Includes Oil Filter) - liter (U.S. gal)	180 (47.6)
Maximum Angle of Installation (Std. Pan)	Front Down 6.5°
(Engine Only)	Front Up 6.5°
	Side to Side 22.5°

COOLING SYSTEM

Coolant Capacity (Engine only) - liter (U.S. gal)	125 (33.0)
Maximum External Friction Head at Engine Outlet - kgf/cm ² (psi)	0.35 (5.0)
Maximum Static Head of Coolant above Crankshaft Center - m(ft)	10 (32.8)
Maximum Outlet Pressure of Engine Water Pump - kgf/cm ² (psi)	2 (28.6)
Standard Thermostat (modulating) Range-°C(°F)	71~85 (160~185)
Maximum Coolant Temperature at Engine Outlet-°C(°F)	98 (208)
Minimum Coolant Expansion Space - % of System Capacity	10
Maximum Coolant Temperature at Intercooler Inlet, TK type-°C(°F)	
Maximum Air Restriction on Discharge Side of Radiator and Fan-mm H ₂ O(in. H ₂ O)	10 (0.4)

FUEL SYSTEM

Fuel Injector	Mitsubishi PS6 Type × 2
Maximum Suction Head of Feed Pump - mm Hg (in. Hg)	75 (3.0)
Maximum Static Head of Return & Leak Pipe - mm Hg (in.Hg)	150 (5.9)

STARTING SYSTEM

Battery Charging Alternator - V-Ah	24-30
Starting Motor Capacity - V -kW	24-7.5×2
Maximum Allowable Resistance of Cranking Circuit - mΩ	1.5
Recommended Minimum Battery Capacity:	
At 5°C(41°F) and above - Ah	300
Below 5°C(41°F) through - 5°C(23°F)	600

The specifications are subject to change without notice

S12R-Y1PTA-2

SPECIFICATION SHEET

ENGINE RATING

All data represent net performance with standard accessories such as air cleaner, inlet /exhaust manifolds, fuel oil system, L.O. pump, etc. under the condition of 100kPa(29.6inHg) barometric pressure, 77 °F(25°C) ambient temperature and 30% relative humidity.

ITEM	UNIT	STAND-BY POWER	PRIME POWER	CONTINUOUS C	CONTINUOUS D
		60Hz	60Hz	60Hz	60Hz
Engine Speed	rpm	1800	1800	1800	1800
No. of Cylinders		12			
Bore	mm (in.)	170 (6.69)			
Stroke	mm (in.)	180 (7.09)			
Displacement	liter (in. ³)	49.03 (2992)			
Brake Horse power without Fan	HP (kW)	1881 (1403)	1709 (1275)	1367 (1020)	1220 (910)
Brake Mean Effective Pressure without Fan	kgf/cm ² (psi)	19.4 (276)	17.7 (252)	14.1 (201)	12.6 (179)
Mean Piston Speed	m/s (ft/min)	10.8 (2126)	10.8 (2126)	10.8 (2126)	10.8 (2126)
Maximum Regenerative Power Absorption Capacity without Fan	HP (kW)	193 (144)	193 (144)	193 (144)	193 (144)
Intake Air flow	m ³ /min (CFM)	126 (4449)	113 (3990)	90 (3178)	81 (2860)
Exhaust Gas Flow	m ³ /min (CFM)	334 (11794)	299 (10558)	238 (8404)	214 (7556)
Coolant Flow	liter/min (U.S. GPM)	1850 (489)	1850 (489)	1850 (489)	1850 (489)
Coolant Flow to Intercooler (TK only)	liter/min (U.S. GPM)	—	—	—	—
Cooling Air Flow (Std. Fan)	m ³ /min (CFM)	1800 (63558)	1800 (63558)	1800 (63558)	1800 (63558)
Fan Loss Horse Power (Std. Fan)	HP (kW)	67 (50)	67 (50)	67 (50)	67 (50)
Radiated Heat to Ambient	kcal/hr (BTU/min)	94956 (6280)	85247 (5638)	67612 (4472)	60955 (4031)
Heat Rejection to Coolant	kcal/hr (BTU/min)	791303 (52336)	710394 (46985)	563434 (37265)	507959 (33596)
Heat Rejection to Inter Cooler (TK Version)	kcal/hr (BTU/min)	—	—	—	—
Heat Rejection to Exhaust	kcal/hr (BTU/min)	1072611 (70941)	949650 (62809)	745662 (49317)	680477 (45006)
Noise Level (1 m height & distance) (excludes, Intake,Exhaust & Fan)	dB(A)	110	108		

The specifications are subject to change without notice

APPLICATION : GENERATOR

Pub. No. T13-0426-E

PI734B - Technical Data Sheet

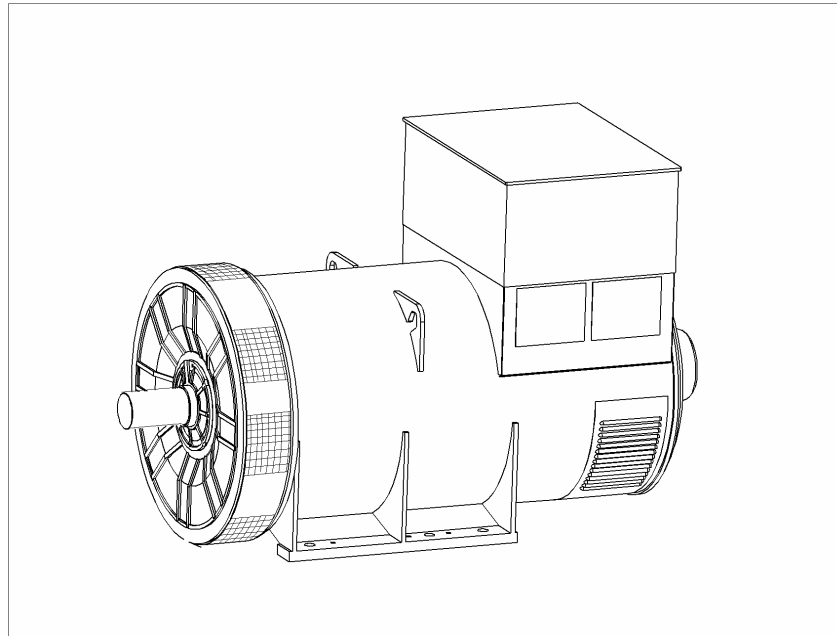

PI734B

SPECIFICATIONS & OPTIONS



STANDARDS

Newage Stamford industrial generators meet the requirements of BS EN 60034 and the relevant sections of other national and international standards such as BS5000, VDE 0530, NEMA MG1-32, IEC60034, CSA C22.2-100, AS1359.

Other standards and certifications can be considered on request.

DESCRIPTION

The STAMFORD PI range of synchronous ac generators are brushless with a rotating field. They are separately excited by the STAMFORD Permanent Magnet Generator (PMG). This is a shaft mounted, high frequency, pilot exciter which provides a constant supply of clean power via the Automatic Voltage Regulator (AVR) to the main exciter. The main exciter output is fed to the main rotor, through a full wave bridge rectifier, protected by surge suppression.

VOLTAGE REGULATORS

The PI range generators, complete with a PMG, are available with one of two AVRs. Each AVR has soft start voltage build up and built in protection against sustained over-excitation, which will de-excite the generator after a minimum of 8 seconds.

Underspeed protection (UFRO) is also provided on both AVRs. The UFRO will reduce the generator output voltage proportional to the speed of the generator below a pre-settable level.

The **MX341 AVR** is two phase sensed with a voltage regulation of $\pm 1\%$. (see the note on regulation).

The **MX321 AVR** is 3 phase rms sensed with a voltage regulation of 0.5% rms (see the note on regulation). The UFRO circuit has adjustable slope and dwell for controlled recovery from step loads. An over voltage protection circuit will shutdown the output device of the AVR, it can also trip an optional excitation circuit breaker if required. As an option, short circuit current limiting is available with the addition of current transformers.

Both the MX341 and the MX321 need a generator mounted current transformer to provide quadrature droop characteristics for load sharing during parallel operation. Provision is also made for the connection of the STAMFORD power factor controller, for embedded applications, and a remote voltage trimmer.

WINDINGS & ELECTRICAL PERFORMANCE

All generator stators are wound to 2/3 pitch. This eliminates triplen (3rd, 9th, 15th ...) harmonics on the voltage waveform and is found to be the optimum design for trouble-free supply of non-linear loads. The 2/3 pitch design avoids excessive neutral currents sometimes seen with higher winding pitches. A fully connected damper winding reduces oscillations during paralleling. This winding, with the 2/3 pitch and carefully selected pole and tooth designs, ensures very low levels of voltage waveform distortion.

TERMINALS & TERMINAL BOX

Standard generators feature a main stator with 6 ends brought out to the terminals, which are mounted on the frame at the non-drive end of the generator. A sheet metal terminal box contains the AVR and provides ample space for the customers' wiring and gland arrangements. It has removable panels for easy access.

SHAFT & KEYS

All generator rotors are dynamically balanced to better than BS6861:Part 1 Grade 2.5 for minimum vibration in operation. Two bearing generators are balanced with a half key.

INSULATION/IMPREGNATION

The insulation system is class 'H', and meets the requirements of UL1446.

All wound components are impregnated with materials and processes designed specifically to provide the high build required for static windings and the high mechanical strength required for rotating components.

QUALITY ASSURANCE

Generators are manufactured using production procedures having a quality assurance level to BS EN ISO 9001.

NOTE ON REGULATION

The stated voltage regulation may not be maintained in the presence of certain radio transmitted signals. Any change in performance will fall within the limits of Criteria 'B' of EN 61000-6-2:2001. At no time will the steady-state voltage regulation exceed 2%.

Note: Continuous development of our products entitles us to change specification details without notice, therefore they must not be regarded as binding.

Front cover drawing is typical of the product range.

PI734B
WINDING 312

CONTROL SYSTEM	SEPARATELY EXCITED BY P.M.G.		
A.V.R.	MX341	MX321	
VOLTAGE REGULATION	± 1%	± 0.5 %	With 4% ENGINE GOVERNING
SUSTAINED SHORT CIRCUIT	REFER TO SHORT CIRCUIT DECREMENT CURVES (page 7)		

INSULATION SYSTEM	CLASS H							
PROTECTION	IP23							
RATED POWER FACTOR	0.8							
STATOR WINDING	DOUBLE LAYER LAP							
WINDING PITCH	TWO THIRDS							
WINDING LEADS	6							
MAIN STATOR RESISTANCE	0.0016 Ohms PER PHASE AT 22°C STAR CONNECTED							
MAIN ROTOR RESISTANCE	1.67 Ohms at 22°C							
EXCITER STATOR RESISTANCE	17.5 Ohms at 22°C							
EXCITER ROTOR RESISTANCE	0.048 Ohms PER PHASE AT 22°C							
R.F.I. SUPPRESSION	BS EN 61000-6-2 & BS EN 61000-6-4, VDE 0875G, VDE 0875N. refer to factory for others							
WAVEFORM DISTORTION	NO LOAD < 1.5% NON-DISTORTING BALANCED LINEAR LOAD < 5.0%							
MAXIMUM OVERSPEED	2250 Rev/Min							
BEARING DRIVE END	BALL. 6228 C3							
BEARING NON-DRIVE END	BALL. 6319 C3							
	1 BEARING				2 BEARING			
WEIGHT COMP. GENERATOR	2760 kg				2710 kg			
WEIGHT WOUND STATOR	1306 kg				1306 kg			
WEIGHT WOUND ROTOR	1139 kg				1077 kg			
WR ² INERTIA	32.7498 kgm ²				31.7489 kgm ²			
SHIPPING WEIGHTS in a crate	2833kg				2779kg			
PACKING CRATE SIZE	194 x 105 x 154(cm)				194 x 105 x 154(cm)			
	50 Hz				60 Hz			
TELEPHONE INTERFERENCE	THF<2%				TIF<50			
COOLING AIR	2.69 m ³ /sec 5700 cfm				3.45 m ³ /sec 7300 cfm			
VOLTAGE STAR	380/220	400/231	415/240	440/254	416/240	440/254	460/266	480/277
kVA BASE RATING FOR REACTANCE VALUES	1360	1400	1400	1375	1525	1625	1655	1690
X _d DIR. AXIS SYNCHRONOUS	3.50	3.26	3.02	2.64	4.25	4.04	3.77	3.53
X' _d DIR. AXIS TRANSIENT	0.21	0.20	0.18	0.16	0.26	0.25	0.23	0.22
X'' _d DIR. AXIS SUBTRANSIENT	0.16	0.15	0.14	0.12	0.19	0.18	0.17	0.16
X _q QUAD. AXIS REACTANCE	2.26	2.10	1.95	1.70	2.74	2.61	2.43	2.28
X'' _q QUAD. AXIS SUBTRANSIENT	0.32	0.29	0.27	0.24	0.38	0.37	0.34	0.32
X _L LEAKAGE REACTANCE	0.04	0.04	0.03	0.03	0.05	0.05	0.04	0.04
X ₂ NEGATIVE SEQUENCE	0.22	0.21	0.19	0.17	0.27	0.26	0.24	0.23
X ₀ ZERO SEQUENCE	0.03	0.03	0.02	0.02	0.03	0.03	0.03	0.03
REACTANCES ARE SATURATED				VALUES ARE PER UNIT AT RATING AND VOLTAGE INDICATED				
T' _d TRANSIENT TIME CONST.	0.13s							
T'' _d SUB-TRANSTIME CONST.	0.01s							
T' _{do} O.C. FIELD TIME CONST.	2.14s							
T _a ARMATURE TIME CONST.	0.02s							
SHORT CIRCUIT RATIO	1/X _d							

**50
Hz**

PI734B
Winding 312



THREE PHASE EFFICIENCY CURVES

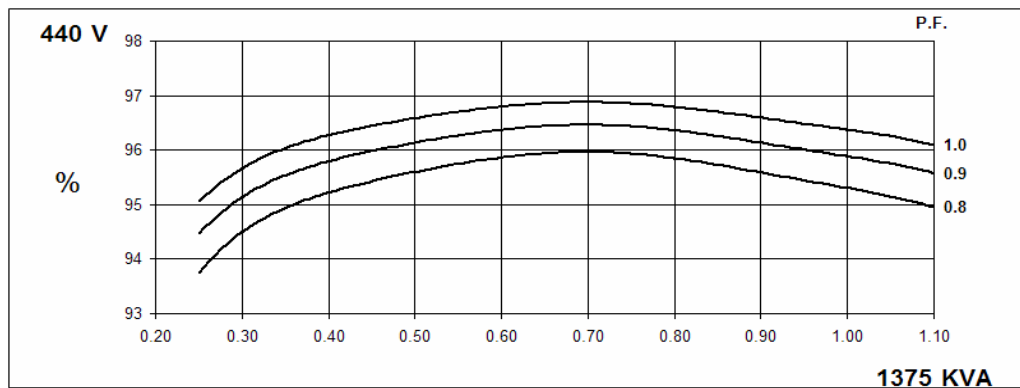
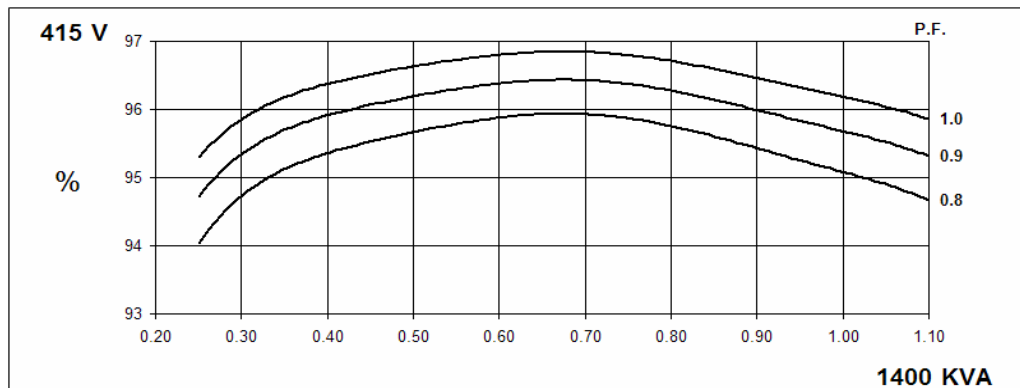
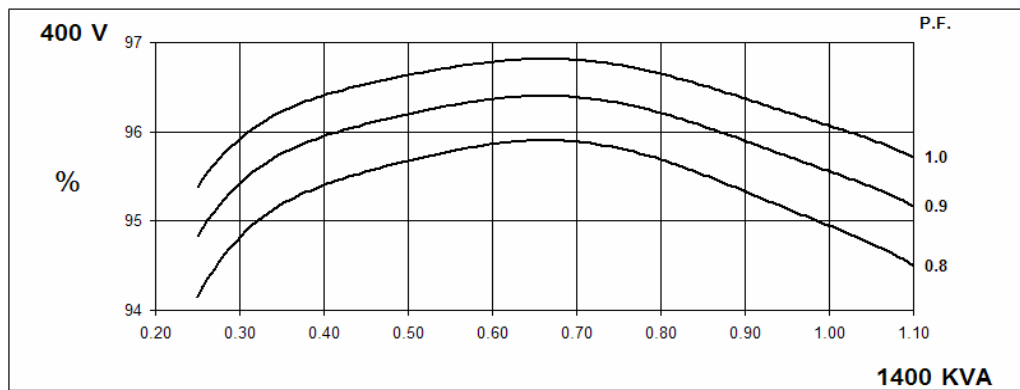
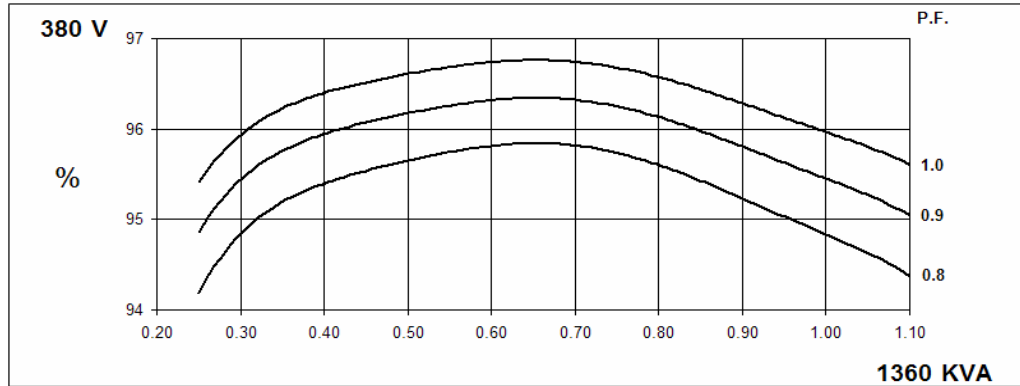

THREE PHASE EFFICIENCY CURVES

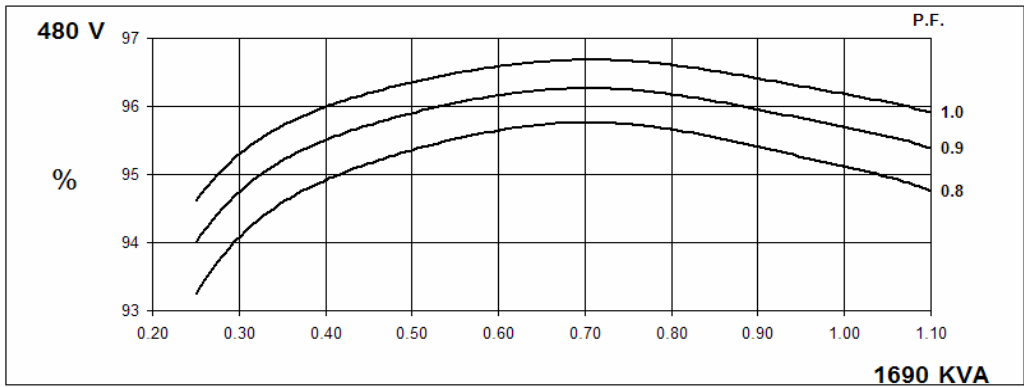
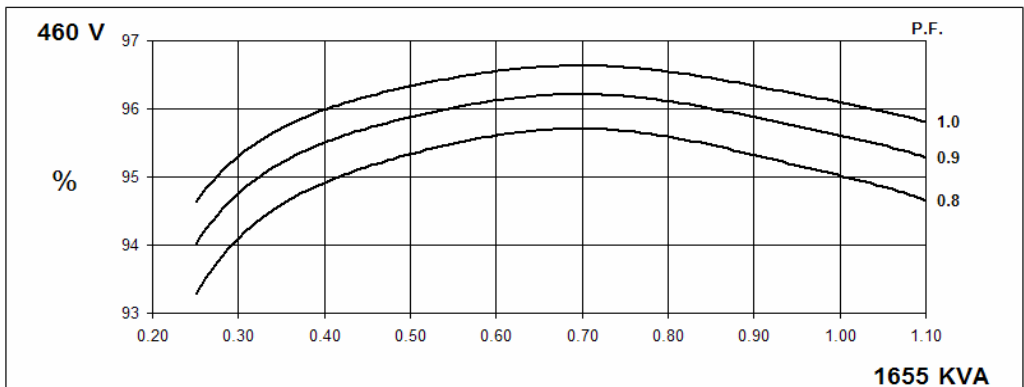
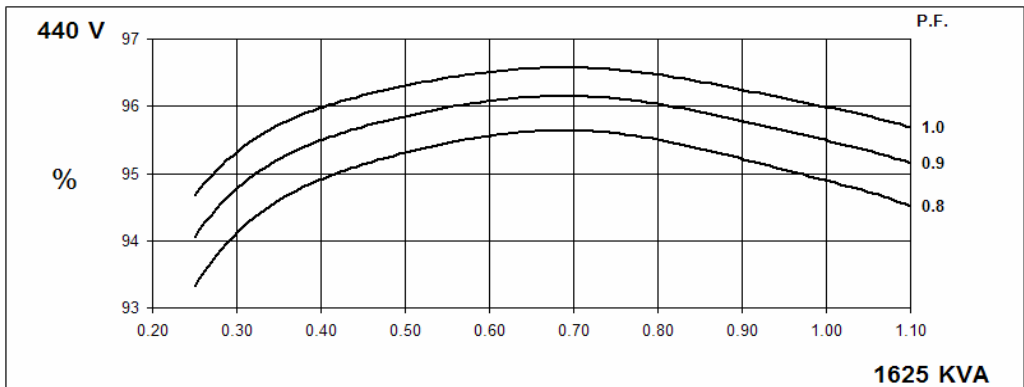
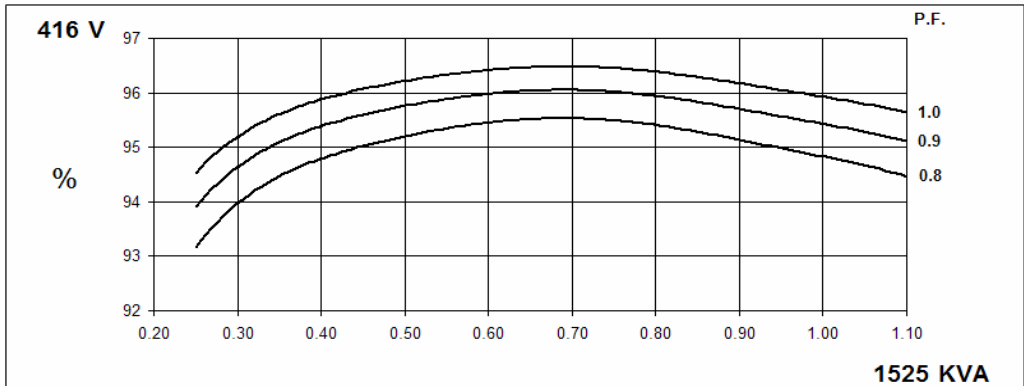

PI734B
Winding 312



Locked Rotor Motor Starting Curve

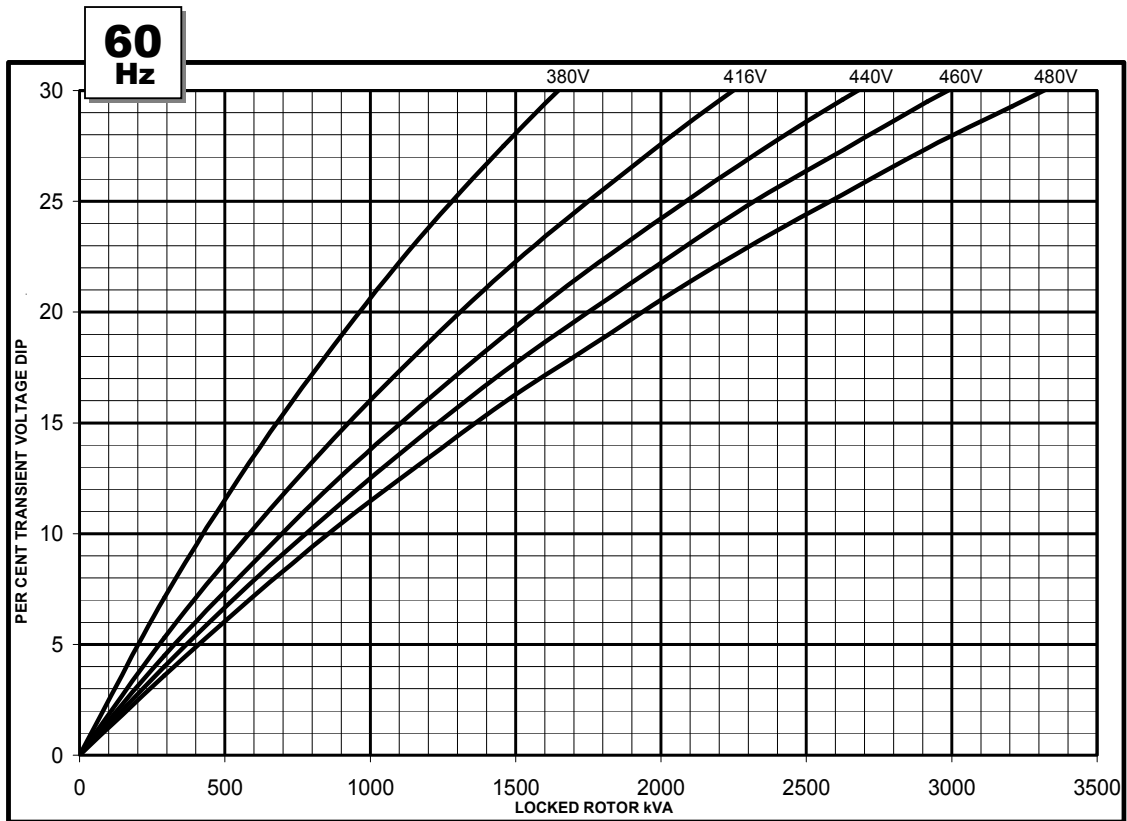
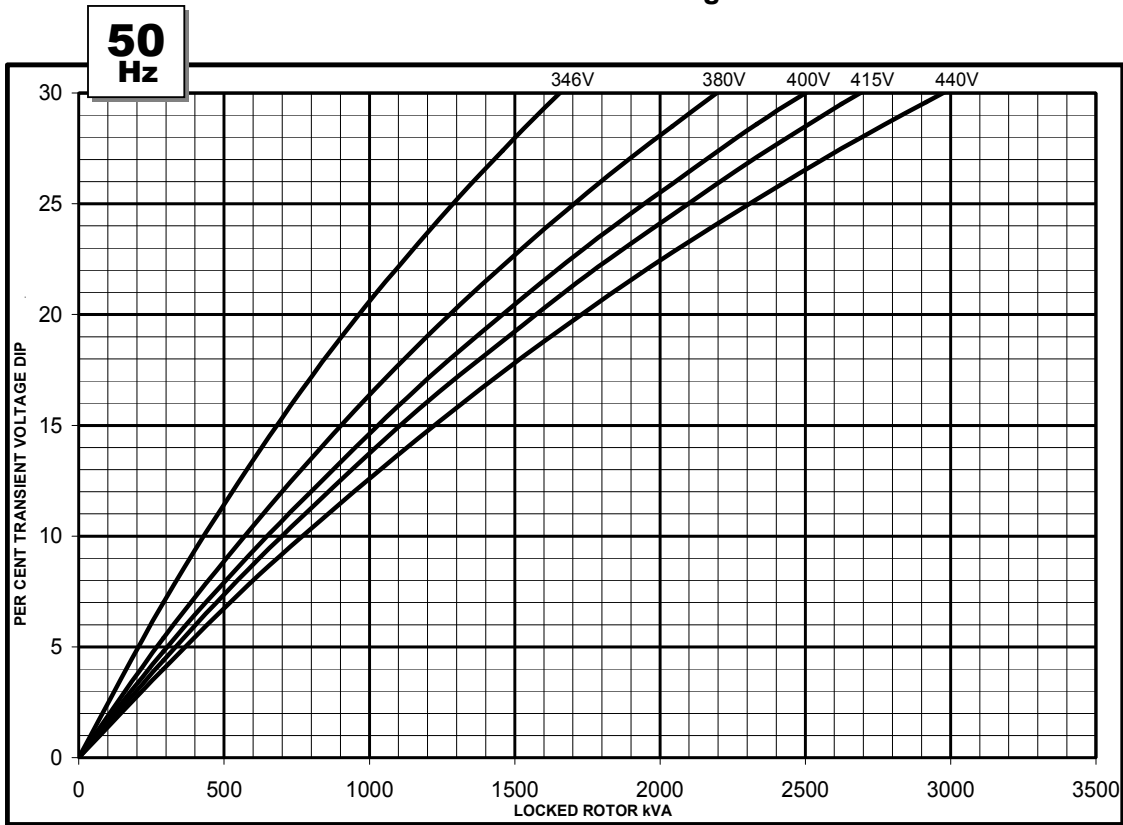

**Three-phase Short Circuit Decrement Curve. No-load Excitation at Rated Speed
Based on star (wye) connection.**

**50
Hz**

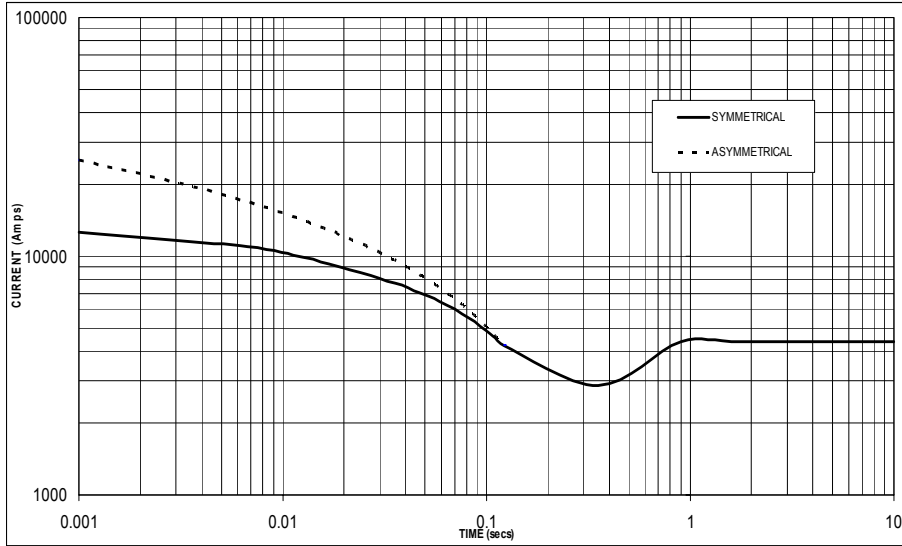

Sustained Short Circuit = 4,400 Amps

**60
Hz**

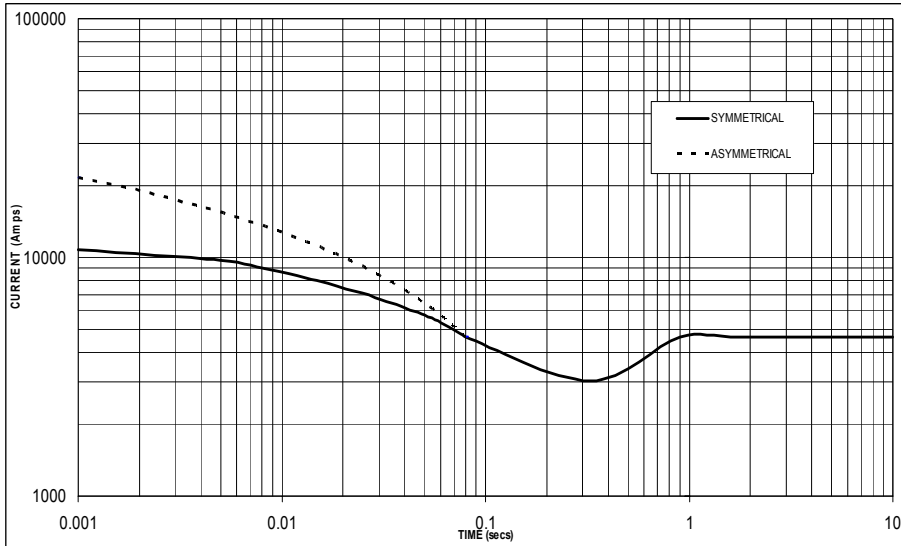

Sustained Short Circuit = 4,650 Amps

Note 1

The following multiplication factors should be used to adjust the values from curve between time 0.001 seconds and the minimum current point in respect of nominal operating voltage :

50Hz		60Hz	
Voltage	Factor	Voltage	Factor
380v	x 1.00	416v	x 1.00
400v	x 1.05	440v	x 1.06
415v	x 1.09	460v	x 1.10
440v	x 1.16	480v	x 1.15

The sustained current value is constant irrespective of voltage level

Note 2

The following multiplication factor should be used to convert the values calculated in accordance with NOTE 1 to those applicable to the various types of short circuit :

	3-phase	2-phase L-L	1-phase L-N
Instantaneous	x 1.00	x 0.87	x 1.30
Minimum	x 1.00	x 1.80	x 3.20
Sustained	x 1.00	x 1.50	x 2.50
Max. sustained duration	10 sec.	5 sec.	2 sec.

All other times are unchanged

Note 3

Curves are drawn for Star (Wye) connected machines.

PI734B

Winding 312 / 0.8 Power Factor



RATINGS

Class - Temp Rise		Cont. F - 105/40°C				Cont. H - 125/40°C				Standby - 150/40°C				Standby - 163/27°C			
50Hz	Star (V)	380	400	415	440	380	400	415	440	380	400	415	440	380	400	415	440
	kVA	1265	1305	1305	1280	1360	1400	1400	1375	1415	1460	1460	1430	1455	1500	1500	1470
	kW	1012	1044	1044	1024	1088	1120	1120	1100	1132	1168	1168	1144	1164	1200	1200	1176
	Efficiency (%)	95.1	95.2	95.3	95.5	94.8	98.9	95.1	95.3	94.7	94.8	94.9	95.2	94.6	94.7	94.9	95.1
	kW Input	1064	1097	1095	1072	1148	1180	1178	1154	1195	1232	1231	1202	1230	1267	1264	1237

60Hz	Star (V)	416	440	460	480	416	440	460	480	416	440	460	480	416	440	460	480
	kVA	1415	1510	1540	1575	1525	1625	1655	1690	1590	1690	1725	1760	1630	1740	1775	1810
	kW	1132	1208	1232	1260	1220	1300	1324	1352	1272	1352	1380	1408	1304	1392	1420	1448
	Efficiency (%)	95.0	95.1	95.2	95.3	94.8	94.9	95.0	95.1	94.7	94.8	94.9	95.0	94.6	94.7	94.8	94.9
	kW Input	1192	1270	1294	1322	1287	1370	1394	1422	1343	1426	1454	1482	1378	1470	1498	1526

DIMENSIONS

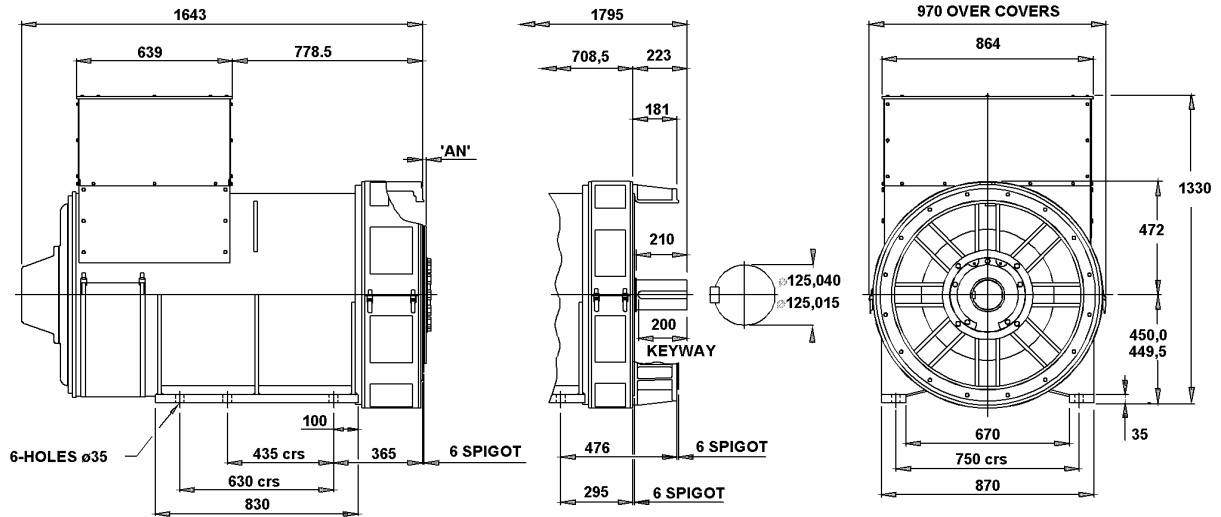

COUPLING DISC	'AN'
S.A.E No 18	15,7
S.A.E No 21	0
S.A.E No 24	0

1-BRG ADAPTORS
S.A.E No 0
S.A.E No 00

2-BRG ADAPTORS
S.A.E No 0
S.A.E No 00



Barnack Road • Stamford • Lincolnshire • PE9 2NB
 Tel: 00 44 (0)1780 484000 • Fax: 00 44 (0)1780 484100
 Website: www.newage-avkseg.com