



ottomotores

DOOSAN Serie P126TI-II

Energía que Mueve al Mundo

DNY315

Definición

El rendimiento del motor se corresponde con la norma **ISO 3046, BS 5514 y DIN 6271.**

Las clasificaciones se basan en la norma **ISO 8528.** (Si necesita más información, póngase en contacto con la organización de ventas.)

Potencia Prime

Está disponible para un número ilimitado de horas al año en una aplicación de carga variable. La potencia media consumible durante 24 horas de operación no deberá sobrepasar el 70% de la potencia nominal.

Potencia Standby

Está disponible en el caso de un corte de suministro eléctrico o en condiciones de prueba para un máximo de 200 horas de funcionamiento por año. La potencia media consumible durante 24 horas de operación no deberá exceder de 70% de la potencia nominal. No se permite sobrecarga. % De la potencia de reserva.

Tabla de Potencias

Modelo	Voltaje	kVA Prime	kWe Prime	kVA Stand-by	kWe Stand-by
DNY315	440-220V	360	288	395	316

0.8 Factor de Potencia



Datos Técnicos

Motor:	P126TI-II
Generador:	Stamford HCI434D
Numero de Cilindros	6 In-line
Diametro por Carrera:	123(4.84) x 155(6.1) mm(in)
Relación de Compresión:	17.0:1
Aspiración:	Turbo y postenfriado (aire - aire)
Desplazamiento:	11.051(647.5) lts(in ³)
Consumo a plena carga:	89.5 lts - 100% carga
Frecuencia:	60 Hz
Velocidad:	1800 rpm
Presion Efectiva:	Max. 0.9 kg/cm ² (12.8 psi)
Flujo de Agua:	320 lts/min.
Calor rechazado en refrigerante:	32.2 kcal/sec
Flujo de Aire:	28.2 m ³ /min
Flujo de Escape:	64.2 m ³ /min
Temperatura de Escape:	580°C

Restricciones Max. Permisibles

Sistema de Admision:	220mmH ² O initial - 635mmH ² O final
Sistema de Escape:	600mmH ² O max
Sistema de Aislamiento	Clase H
Sistema de control:	Separado y exitado por PMG
AVR	MX341

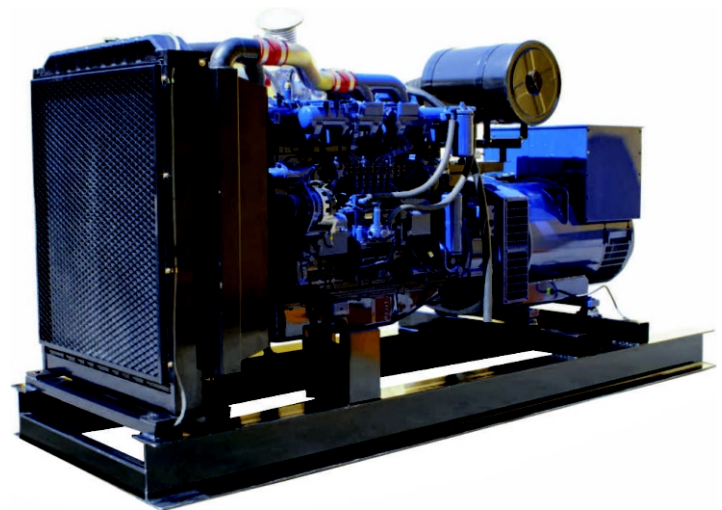

Nota: Imagen de carácter ilustrativa ya que los equipos en foto pudieran incluir accesorios opcionales

Como leer nuestro codigo Ejem: **DNY315**

D = Motor Doosan
N =Generador Newage Stamford
Y = Frecuencia 60Hz-1800 RPM
315 =Potencia del Equipo.



LAPEM

Ottomotores, S.A de C.V.

Calz. San Lorenzo No.1150
Col. Cerro de la estrella, C.P. 09860
Delg. Iztapalapa México, D.F.
Tels:52-55-5624-5600

Fax: 52-55-5426-5521 / 52-55-5426-5581
email sales : ventas@ottomotores.com.mx
sitio web: www.ottomotores.com.mx

Dimensiones

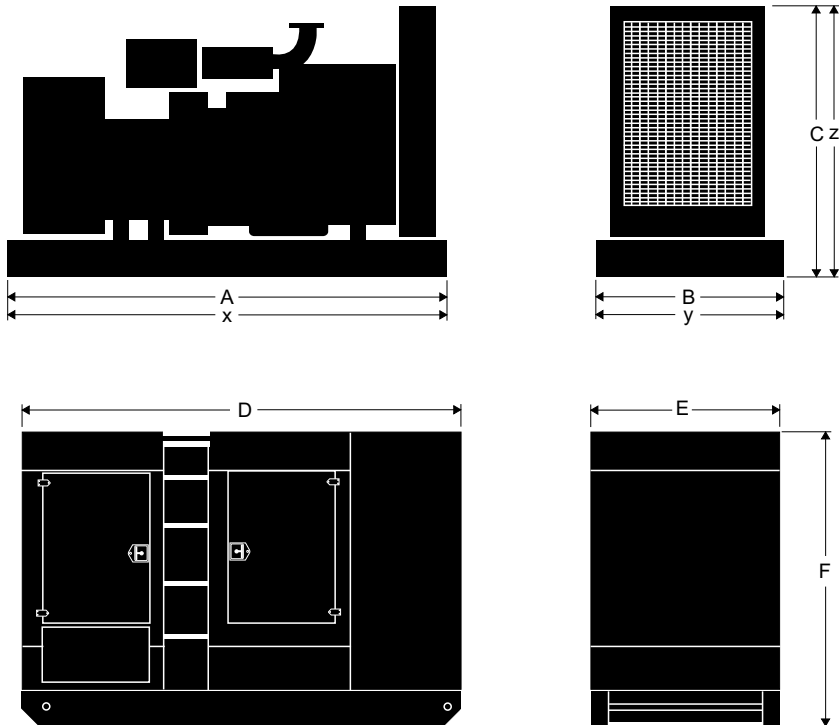

Modelo	Equipo con Base Estructural			Equipo con Base Tanque			Equipo con Caseta Acústica*		
	A	B	C	x	y	z	D	E	F
C.pack	290,00	110,00	146,00	320,00	145,00	158,00	400,00	145,00	205,00
	Peso: 2106,00 kgs			Peso: 2917,00 kgs			Peso: 3516,00 kgs		

[*] optional

Información Técnica

Nota: las condiciones de referencia estándar son de 25 °C (77 ° F) temperatura de entrada de aire. Todos los datos de desempeño de motores son basados en la potencia mencionada arriba.

Datos de consumo de combustible a plena carga con combustible diesel tienen una gravedad específica de 0,85.

Comercializado por:

Módulos de Control



Ottomotores tiene una posición única en la fabricación de grupos electrógenos utilizando en ellos módulos de control que cumplen con todos los niveles de requerimiento del mercado nacional y de exportación.



Las diferentes soluciones de controles que se tienen para nuestra gama de plantas generadoras, permite una operación simple en modo manual y automático, así mismo permiten desarrollar proyectos de sincronía entre plantas generadoras o con la red de energía eléctrica.



La familia de módulos de control en transición abierta (DALE 3200) permite tener control en forma automática de la unidad de transferencia, así como el monitoreo del grupo generador.



Nuestro módulos de control cuentan con puerto de comunicación RS485 para la comunicación remota con el grupo generador.



Los módulos pueden ser monitoreados através de un excelente software para observar parámetros del equipo de manera fácil y rápida.



La familia de módulos de control para la sincronía (6100, 6050 y 6300), incorporan un amplio sistema de monitoreos además de conexión a Internet (LAN) o mensaje SMS vía celular, o usando los puertos de comunicación RS485 a través de ModBus



ottomotores

Energía que Mueve al Mundo

Calz. San Lorenzo No.1150
Col. Cerro de la Estrella, C.P.09860
Delegación Iztapalapa México D.F.
Tels: 52-55-5624-5600
Fax.52-55-5426-55-21 / 52-55-54265581

E-mail ventas1@ottomotores.com.mx
ventas2@ottomotores.com.mx

Web site. www.ottomotores.com.mx

POWER RATING

Engine Speed rev/min	Type of Operation	Engine Power	
		kWm	Ps
1800	Continuous Power	*	*
	Prime Power	307	418
	Standby Power	342	465
1500	Continuous Power	*	*
	Prime Power	265	360
	Standby Power	294	400

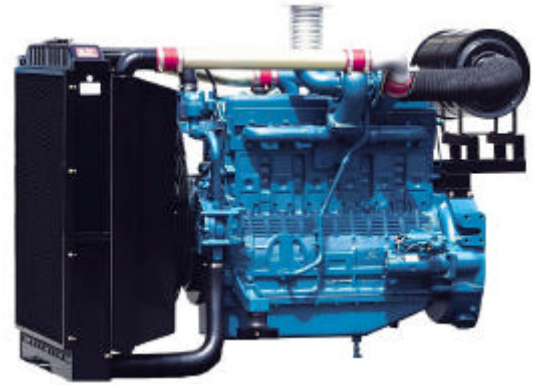

Note : -. The engine performance corresponds to ISO 3046, BS 5514 and DIN 6271.

-. Ratings are based on ISO 8528.

Prime power available at variable load. The permissible average power out put (during 24h period) shall not exceed 70% of the prime power rating.

Standby power available in the event of a main power network failure. No overload is permitted.

MECHANICAL SYSTEM

○ Engine Model	P126TI-
○ Engine Type	In-line 4 cycle, water cooled Turbo charged & intercooled (air to air)
○ Combustion type	Direct injection
○ Cylinder Type	Replaceable dry liner
○ Number of cylinders	6
○ Bore x stroke	123(4.84) x 155(6.1) mm(in.)
○ Displacement	11.051(674.5) lit.(in ³)
○ Compression ratio	17 : 1
○ Firing order	1-5-3-6-2-4
○ Injection timing	16° BTDC
○ Compression pressure	Above 28 kg/cm ² (398 psi) at 200rpm
○ Dry weight	Approx. 910 kg (2,006 lb)
○ Dimension (LxWxH)	1,383 x 870 x 1,207 mm (54.4 x 34.3 x 47.5 in.)
○ Rotation	Counter clockwise viewed from Flywheel
○ Fly wheel housing	SAE NO.1
○ Fly wheel	Clutch NO.14

MECHANISM

○ Type	Over head valve
○ Number of valve	Intake 1, exhaust 1 per cylinder
○ Valve lashes at cold	Intake 0.30mm (0.0118 in.) Exhaust 0.30mm (0.0118 in.)

VALVE TIMING

	Opening	Close
○ Intake valve	18 deg. BTDC	34 deg. ABDC
○ Exhaust valve	46 deg. BBDC	14 deg. ATDC

FUEL CONSUMPTION

○ Prime Power (lit/hr)	1,500 rpm	1,800 rpm
	25%	20.6
	50%	37
	75%	56
○ Standby Power (lit/h)	1,500 rpm	1,800 rpm
	25%	22.2
	50%	41.4
	75%	61.5
100%	77.6	89.5

FUEL SYSTEM

○ Injection pump	Zexel in-line "P" type
○ Governor	Electric type
○ Feed pump	Mechanical type
○ Injection nozzle	Multi hole type
○ Opening pressure	220 kg/cm ² (3,129 psi)
○ Fuel filter	Full flow, cartridge type
○ Used fuel	Diesel fuel oil

LUBRICATION SYSTEM

○ Lub. Method	Fully forced pressure feed type
○ Oil pump	Gear type driven by crankshaft
○ Oil filter	Full flow, cartridge type
○ Oil pan capacity	High level 23 liters (6.1 gal.) Low level 20 liters (5.3 gal.)
○ Angularity limit	Front down 25 deg. Front up 25 deg. Side to side 15 deg.
○ Lub. Oil	Refer to Operation Manual

P126TI- G-DRIVE

COOLING SYSTEM

- Cooling method Fresh water forced circulation
- Water capacity 19 liters (5.02 gal.)
(engine only)
- Pressure system Max. 0.9 kg/cm² (12.8 psi)
- Water pump Centrifugal type driven by gear
- Water pump Capacity 320 liters (84.5 gal.)/min
at 1,800 rpm (engine)
- Thermostat Wax – pellet type
Opening temp. 71°C
Full open temp. 85°C
- Cooling fan Blower type, plastic
755 mm diameter, 7 blade

ELECTRICAL SYSTEM

- Charging generator 24V x 45A alternator
- Voltage regulator Built-in type IC regulator
- Starting motor 24V x 6.0kW
- Battery Voltage 24V
- Battery Capacity 150 AH (recommended)
- Starting aid (Option) Block heater

ENGINEERING DATA

- Water flow 265 liters/min @1,500 rpm
- Heat rejection to coolant 27.6 kcal/sec @1,500 rpm
- Heat rejection to CAC 8.4 kcal/sec @1,500 rpm
- Air flow 20.1 m³/min @1,500 rpm
- Exhaust gas flow 47.4 m³/min @1,500 rpm
- Exhaust gas temp. 590 °C @1,500 rpm

- Water flow 320 liters/min @1,800 rpm
- Heat rejection to coolant 32.2 kcal/sec @1,800 rpm
- Heat rejection to CAC 14.9 kcal/sec @1,800 rpm
- Air flow 28.2 m³/min @1,800 rpm
- Exhaust gas flow 64.2 m³/min @1,800 rpm
- Exhaust gas temp. 580 °C @1,800 rpm

- Max. permissible restrictions
- .Intake system 220 mmH₂O initial
635 mmH₂O final
- .Exhaust system 600 mmH₂O max.

CONVERSION TABLE

- | | |
|------------------------------------|------------------------------------|
| in. = mm x 0.0394 | lb/ft = N.m x 0.737 |
| PS = kW x 1.3596 | U.S. gal = lit. x 0.264 |
| psi = kg/cm ² x 14.2233 | kW = 0.2388 kcal/s |
| in ³ = lit. x 61.02 | lb/PS.h = g/kW.h x 0.00162 |
| hp = PS x 0.98635 | cfm = m ³ /min x 35.336 |
| lb = kg x 2.20462 | |

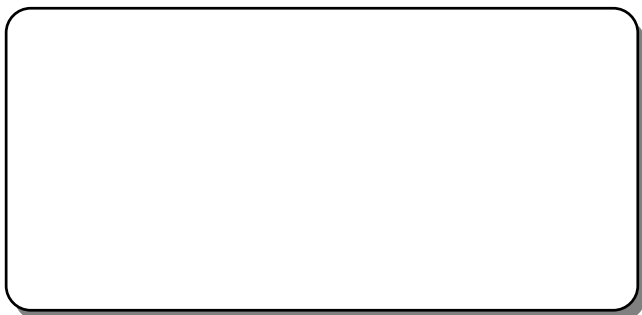
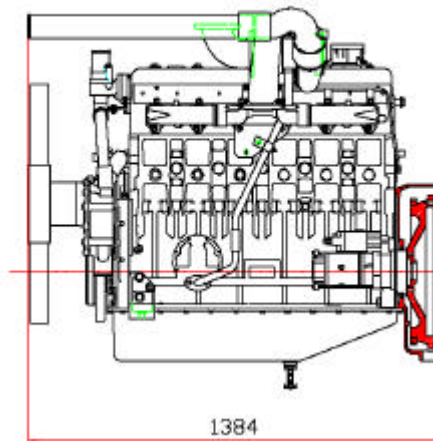
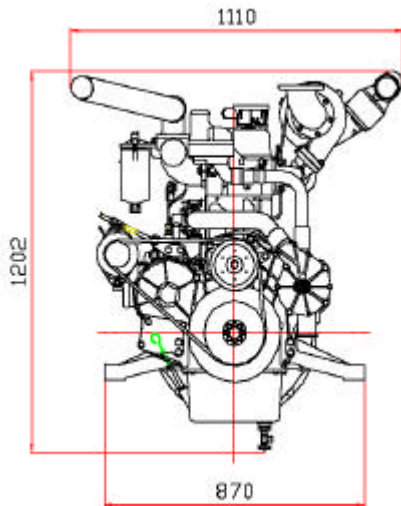

Head office
7-11, Hwasu-Dong, Dong-Gu, Incheon, Korea
TEL : 82-32-760-1437, 1964 FAX : 82-32-760-1964

Seoul Office
Doosan Infracore Co. Ltd.,
22nd Floor, Doosan Tower, 18-12, Euljiro 6-ga, Jung-gu,
Seoul, Korea.
TEL : 82-2-3398-8521~8535 FAX : 82-2-3398-8509
Web site : www.doosaninfracore.com

Specifications are subject to change without prior notice

HCI 434D/444D - Technical Data Sheet

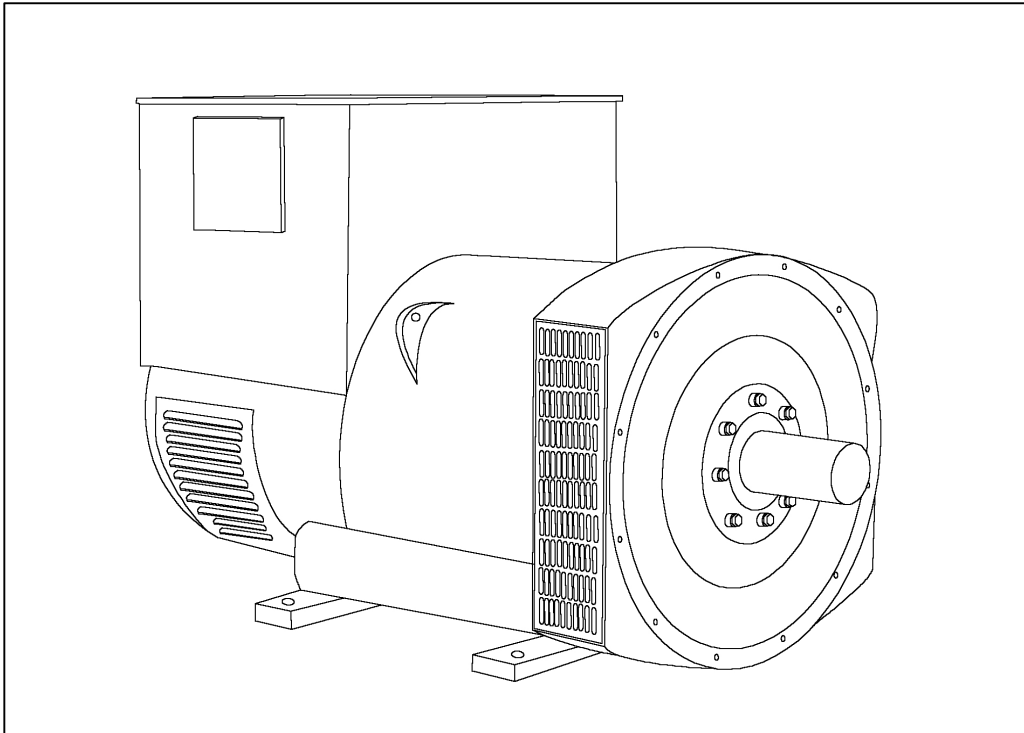

HCI434D/444D

SPECIFICATIONS & OPTIONS



STANDARDS

Newage Stamford industrial generators meet the requirements of BS EN 60034 and the relevant section of other international standards such as BS5000, VDE 0530, NEMA MG1-32, IEC34, CSA C22.2-100, AS1359. Other standards and certifications can be considered on request.

VOLTAGE REGULATORS

SX440 AVR - STANDARD

With this self-excited system the main stator provides power via the Automatic Voltage Regulator (AVR) to the exciter stator. The high efficiency semi-conductors of the AVR ensure positive build-up from initial low levels of residual voltage.

The exciter rotor output is fed to the main rotor through a three-phase full-wave bridge rectifier. The rectifier is protected by a surge suppressor against surges caused, for example, by short circuit or out-of-phase paralleling.

The SX440 will support a range of electronic accessories, including a 'droop' Current Transformer (CT) to permit parallel operation with other ac generators.

If 3-phase sensing is required with the self-excited system, the SX421 AVR must be used.

SX421 AVR

This AVR also operates in a self-excited system. It combines all the features of the SX440 with, additionally, three-phase rms sensing for improved regulation and performance. Over voltage protection is provided via a separate circuit breaker. An engine relief load acceptance feature is built in as standard.

MX341 AVR

This sophisticated AVR is incorporated into the Stamford Permanent Magnet Generator (PMG) control system.

The PMG provides power via the AVR to the main exciter, giving a source of constant excitation power independent of generator output. The main exciter output is then fed to the main rotor, through a full wave bridge, protected by a surge suppressor. The AVR has in-built protection against sustained over-excitation, caused by internal or external faults. This de-excites the machine after a minimum of 5 seconds.

An engine relief load acceptance feature can enable full load to be applied to the generator in a single step.

If three-phase sensing is required with the PMG system the MX321 AVR must be used.

We recommend three-phase sensing for applications with greatly unbalanced or highly non-linear loads.

MX321 AVR

The most sophisticated of all our AVRs combines all the features of the MX341 with, additionally, three-phase rms sensing, for improved regulation and performance.

Over voltage protection is built-in and short circuit current level adjustments is an optional facility.

WINDINGS & ELECTRICAL PERFORMANCE

All generator stators are wound to 2/3 pitch. This eliminates triplen (3rd, 9th, 15th ...) harmonics on the voltage waveform and is found to be the optimum design for trouble-free supply of non-linear loads. The 2/3 pitch design avoids excessive neutral currents sometimes seen with higher winding pitches, when in parallel with the mains. A fully connected damper winding reduces oscillations during paralleling. This winding, with the 2/3 pitch and carefully selected pole and tooth designs, ensures very low waveform distortion.

TERMINALS & TERMINAL BOX

Standard generators are 3-phase reconnectable with 12 ends brought out to the terminals, which are mounted on a cover at the non-drive end of the generator. A sheet steel terminal box contains the AVR and provides ample space for the customers' wiring and gland arrangements. It has removable panels for easy access.

SHAFT & KEYS

All generator rotors are dynamically balanced to better than BS6861:Part 1 Grade 2.5 for minimum vibration in operation. Two bearing generators are balanced with a half key.

INSULATION/IMPREGNATION

The insulation system is class 'H'.

All wound components are impregnated with materials and processes designed specifically to provide the high build required for static windings and the high mechanical strength required for rotating components.

QUALITY ASSURANCE

Generators are manufactured using production procedures having a quality assurance level to BS EN ISO 9001.

The stated voltage regulation may not be maintained in the presence of certain radio transmitted signals. Any change in performance will fall within the limits of Criteria 'B' of EN 61000-6-2:2001. At no time will the steady-state voltage regulation exceed 2%.

NB Continuous development of our products entitles us to change specification details without notice, therefore they must not be regarded as binding.

Front cover drawing typical of product range.

HCI434D/444D

WINDING 311

CONTROL SYSTEM	SEPARATELY EXCITED BY P.M.G.							
A.V.R.	MX321	MX341						
VOLTAGE REGULATION	± 0.5 %	± 1.0 %	With 4% ENGINE GOVERNING					
SUSTAINED SHORT CIRCUIT	REFER TO SHORT CIRCUIT DECREMENT CURVES (page 7)							
CONTROL SYSTEM	SELF EXCITED							
A.V.R.	SX440	SX421						
VOLTAGE REGULATION	± 1.0 %	± 0.5 %	With 4% ENGINE GOVERNING					
SUSTAINED SHORT CIRCUIT	WILL NOT SUSTAIN A SHORT CIRCUIT							
INSULATION SYSTEM	CLASS H							
PROTECTION	IP23							
RATED POWER FACTOR	0.8							
STATOR WINDING	DOUBLE LAYER LAP							
WINDING PITCH	TWO THIRDS							
WINDING LEADS	12							
STATOR WDG. RESISTANCE	0.0124 Ohms PER PHASE AT 22°C SERIES STAR CONNECTED							
ROTOR WDG. RESISTANCE	1.05 Ohms at 22°C							
EXCITER STATOR RESISTANCE	18 Ohms at 22°C							
EXCITER ROTOR RESISTANCE	0.068 Ohms PER PHASE AT 22°C							
R.F.I. SUPPRESSION	BS EN 61000-6-2 & BS EN 61000-6-4, VDE 0875G, VDE 0875N. refer to factory for others							
WAVEFORM DISTORTION	NO LOAD < 1.5% NON-DISTORTING BALANCED LINEAR LOAD < 5.0%							
MAXIMUM OVERSPEED	2250 Rev/Min							
BEARING DRIVE END	BALL. 6317 (ISO)							
BEARING NON-DRIVE END	BALL. 6314 (ISO)							
	1 BEARING				2 BEARING			
WEIGHT COMP. GENERATOR	940 kg				950 kg			
WEIGHT WOUND STATOR	415 kg				415 kg			
WEIGHT WOUND ROTOR	361 kg				338 kg			
WR ² INERTIA	4.0771 kgm ²				3.8783 kgm ²			
SHIPPING WEIGHTS in a crate	1010 kg				1010 kg			
PACKING CRATE SIZE	155 x 87 x 107(cm)				156 x 87 x 107(cm)			
	50 Hz				60 Hz			
TELEPHONE INTERFERENCE	THF<2%				TIF<50			
COOLING AIR	0.8 m ³ /sec 1700 cfm				0.99 m ³ /sec 2100 cfm			
VOLTAGE SERIES STAR	380/220	400/231	415/240	440/254	416/240	440/254	460/266	480/277
VOLTAGE PARALLEL STAR	190/110	200/115	208/120	220/127	208/120	220/127	230/133	240/138
VOLTAGE SERIES DELTA	220/110	230/115	240/120	254/127	240/120	254/127	266/133	277/138
KVA BASE RATING FOR REACTANCE VALUES	300	300	300	290	340	360	375	375
X _d DIR. AXIS SYNCHRONOUS	3.16	2.85	2.65	2.28	3.56	3.37	3.21	2.95
X' _d DIR. AXIS TRANSIENT	0.20	0.18	0.17	0.15	0.22	0.21	0.20	0.18
X'' _d DIR. AXIS SUBTRANSIENT	0.14	0.13	0.12	0.10	0.15	0.14	0.14	0.12
X _q QUAD. AXIS REACTANCE	2.66	2.40	2.23	1.92	3.05	2.89	2.75	2.53
X'' _q QUAD. AXIS SUBTRANSIENT	0.39	0.36	0.33	0.28	0.40	0.38	0.36	0.33
X _L LEAKAGE REACTANCE	0.07	0.06	0.06	0.05	0.09	0.09	0.08	0.07
X ₂ NEGATIVE SEQUENCE	0.26	0.24	0.22	0.19	0.28	0.27	0.25	0.23
X ₀ ZERO SEQUENCE	0.10	0.09	0.08	0.07	0.10	0.09	0.09	0.08
REACTANCES ARE SATURATED				VALUES ARE PER UNIT AT RATING AND VOLTAGE INDICATED				
T' _d TRANSIENT TIME CONST.	0.08s							
T'' _d SUB-TRANSTIME CONST.	0.019s							
T' _{do} O.C. FIELD TIME CONST.	1.7s							
T _a ARMATURE TIME CONST.	0.018s							
SHORT CIRCUIT RATIO	1/X _d							

**50
Hz**

HCI434D/444D
Winding 311



THREE PHASE EFFICIENCY CURVES

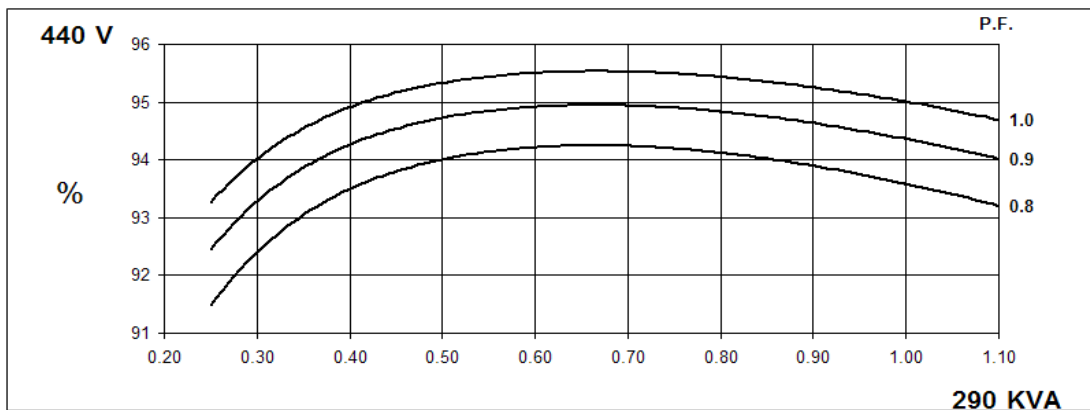
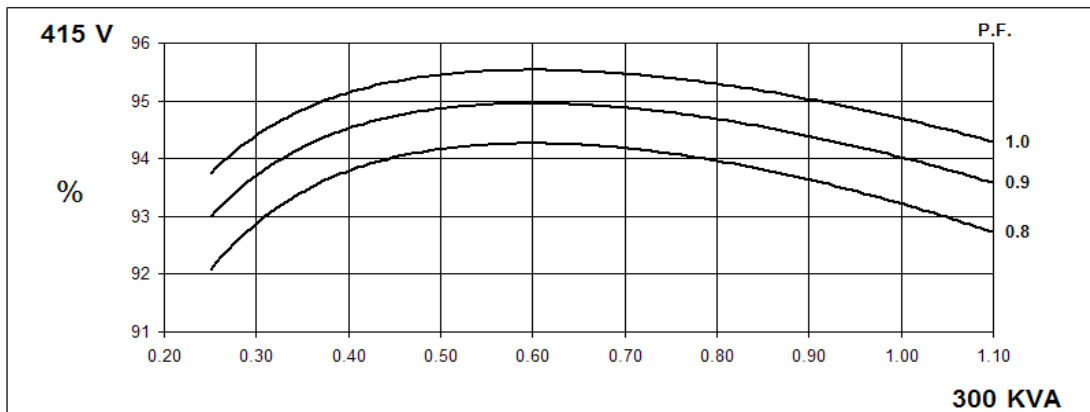
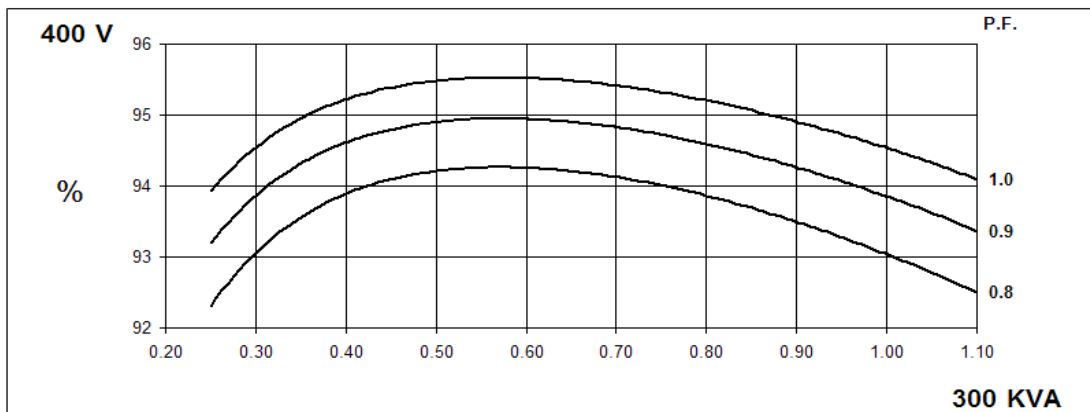
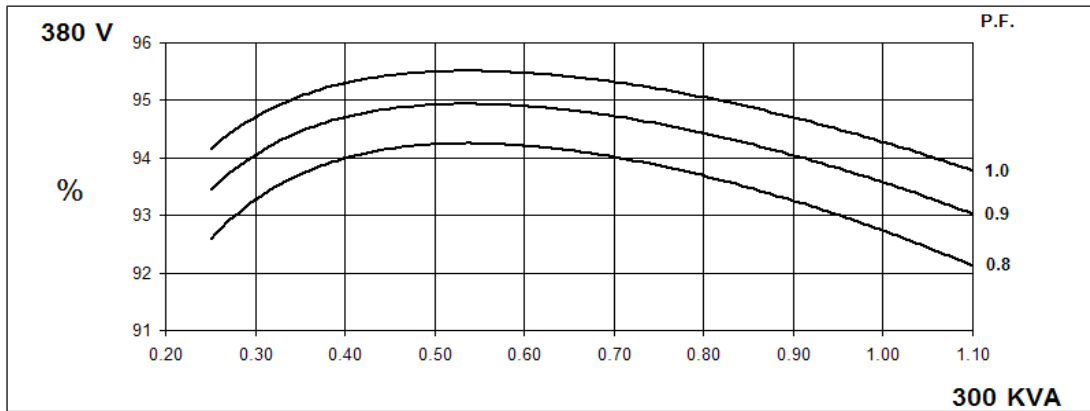

THREE PHASE EFFICIENCY CURVES

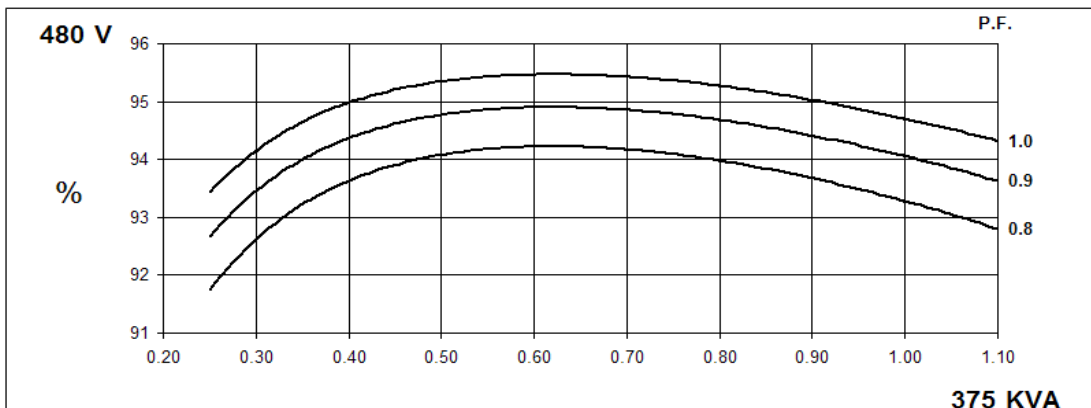
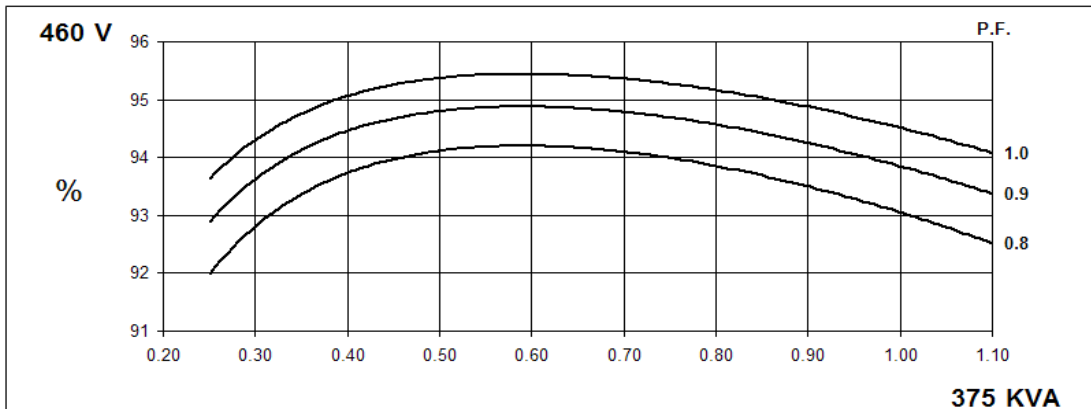
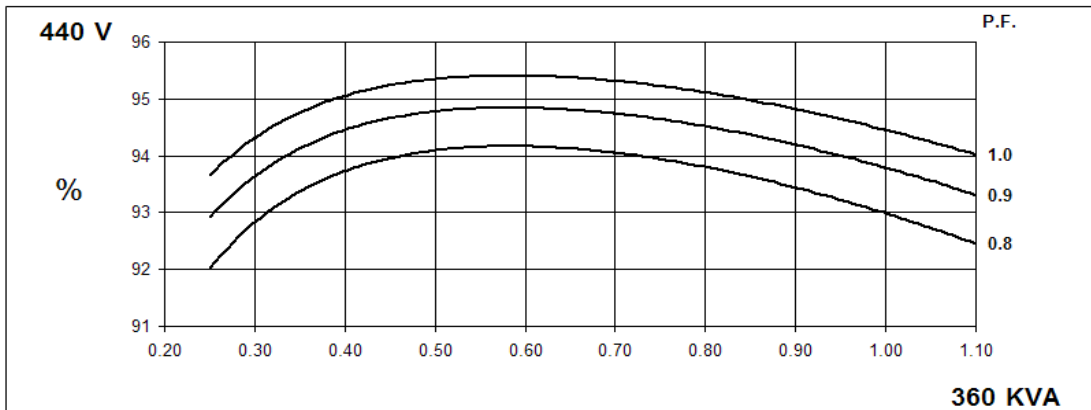
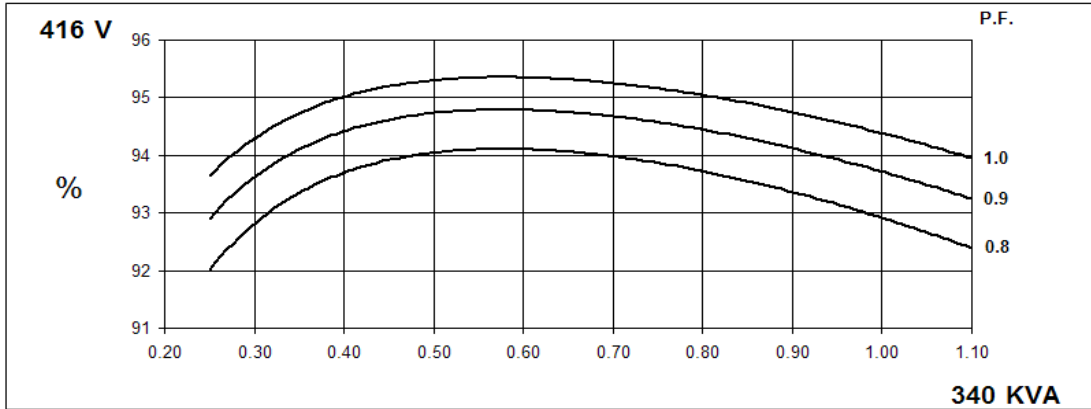

HCI434D/444D

Winding 311



Locked Rotor Motor Starting Curve

**50
Hz**

MX

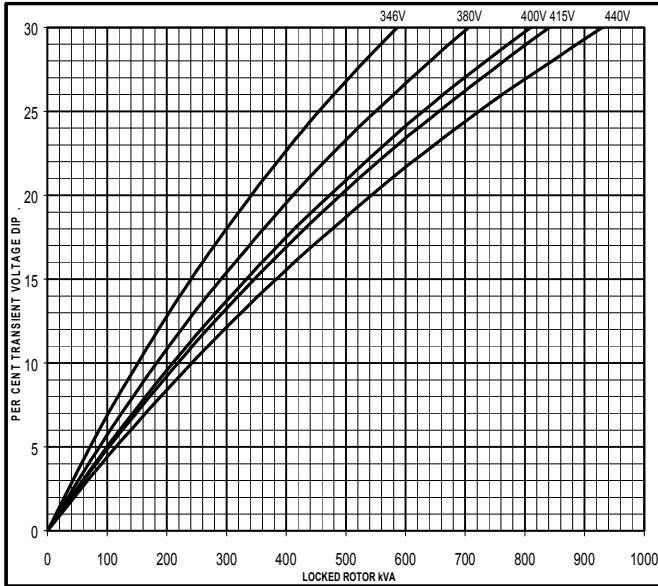

SX

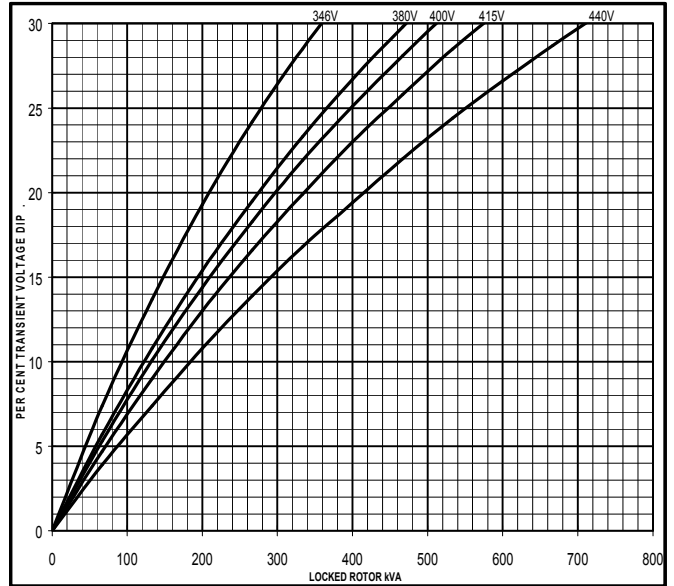

**60
Hz**

MX

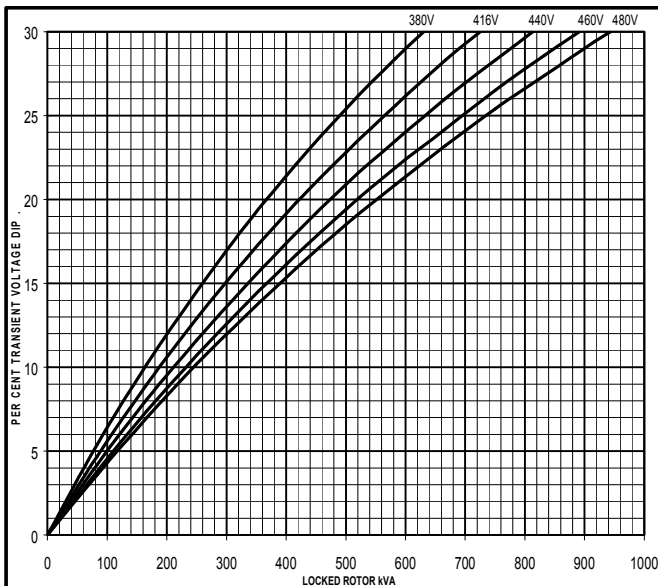

SX

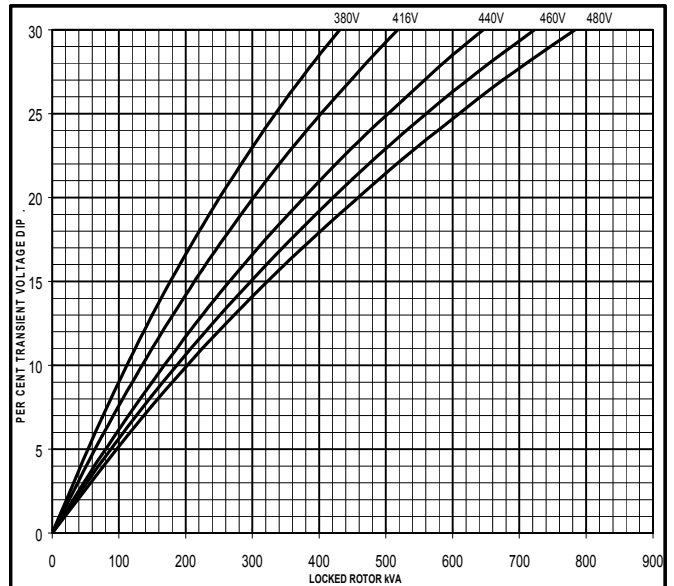

**Three-phase Short Circuit Decrement Curve. No-load Excitation at Rated Speed
Based on star (wye) connection.**

**50
Hz**

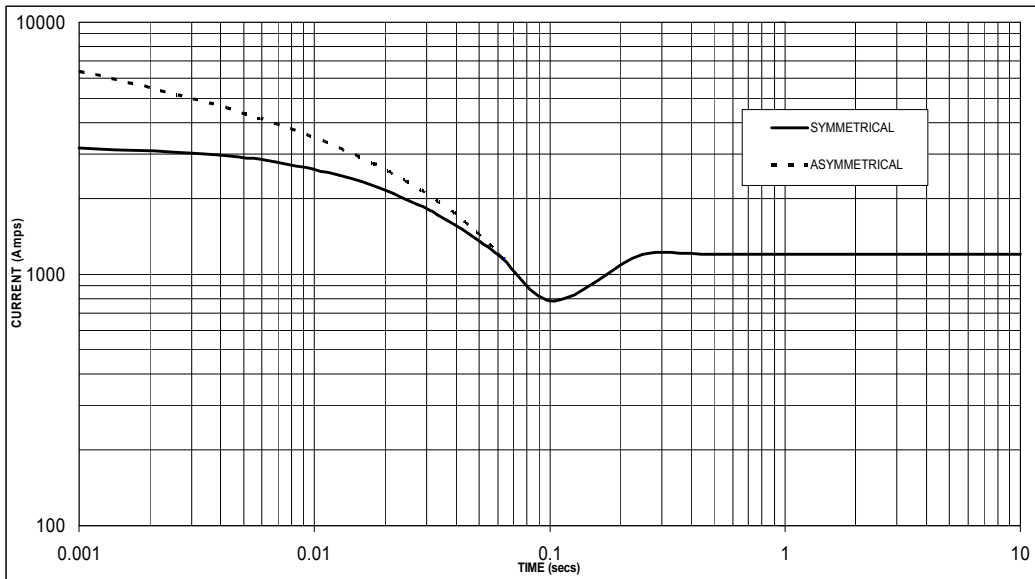

Sustained Short Circuit = 1,200 Amps

**60
Hz**

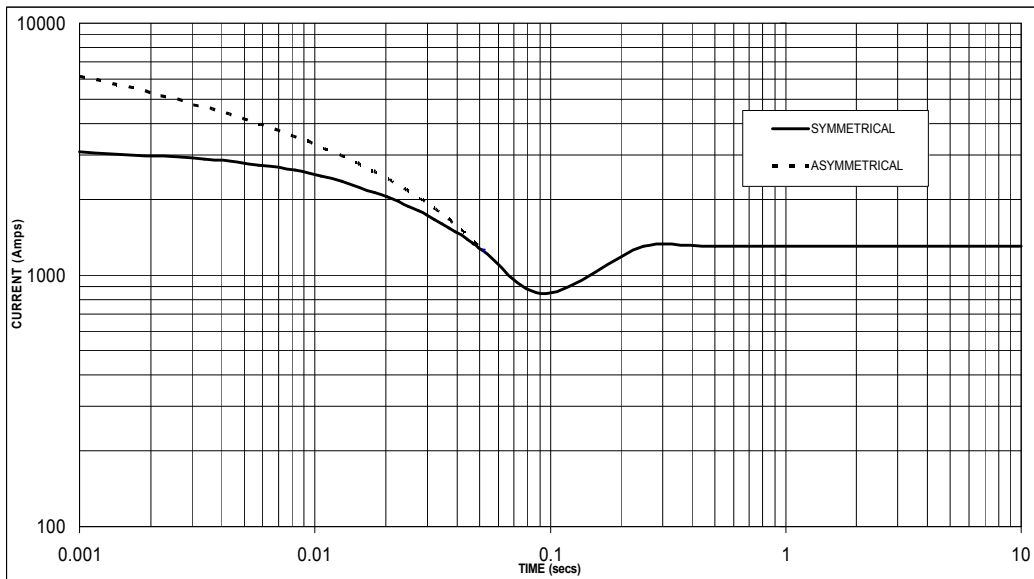

Sustained Short Circuit = 1,300 Amps

Note 1

The following multiplication factors should be used to adjust the values from curve between time 0.001 seconds and the minimum current point in respect of nominal operating voltage :

50Hz		60Hz	
Voltage	Factor	Voltage	Factor
380v	X 1.00	416v	X 1.00
400v	X 1.05	440v	X 1.06
415v	X 1.09	460v	X 1.10
440v	X 1.16	480v	X 1.15

The sustained current value is constant irrespective of voltage level

Note 2

The following multiplication factor should be used to convert the values calculated in accordance with NOTE 1 to those applicable to the various types of short circuit :

	3-phase	2-phase L-L	1-phase L-N
Instantaneous	x 1.00	x 0.87	x 1.30
Minimum	x 1.00	x 1.80	x 3.20
Sustained	x 1.00	x 1.50	x 2.50
Max. sustained duration	10 sec.	5 sec.	2 sec.

All other times are unchanged

Note 3

Curves are drawn for Star (Wye) connected machines. For other connection the following multipliers should be applied to current values as shown :

Parallel Star = Curve current value X 2

Series Delta = Curve current value X 1.732

HCI434D/444D

Winding 311 / 0.8 Power Factor



RATINGS

Class - Temp Rise	Cont. F - 105/40°C				Cont. H - 125/40°C				Standby - 150/40°C				Standby - 163/27°C				
50 Hz	Series Star (V)	380	400	415	440	380	400	415	440	380	400	415	440	380	400	415	440
	Parallel Star (V)	190	200	208	220	190	200	208	220	190	200	208	220	190	200	208	220
	Series Delta (V)	220	230	240	254	220	230	240	254	220	230	240	254	220	230	240	254
kVA	280	280	280	270	300	300	300	290	320	320	320	310	330	330	330	320	
kW	224	224	224	216	240	240	240	232	256	256	256	248	264	264	264	256	
Efficiency (%)	93.1	93.4	93.5	93.8	92.7	93.0	93.2	93.6	92.3	92.7	92.9	93.3	92.1	92.5	92.7	93.2	
kW Input	241	240	240	230	259	258	258	248	277	276	276	266	287	285	285	275	

60 Hz	Series Star (V)	416	440	460	480	416	440	460	480	416	440	460	480	416	440	460	480
	Parallel Star (V)	208	220	230	240	208	220	230	240	208	220	230	240	208	220	230	240
	Series Delta (V)	240	254	266	277	240	254	266	277	240	254	266	277	240	254	266	277
kVA	315	335	345	345	340	360	375	375	365	385	400	400	375	395	415	415	
kW	252	268	276	276	272	288	300	300	292	308	320	320	300	316	332	332	
Efficiency (%)	93.3	93.3	93.4	93.6	92.9	93.0	93.1	93.3	92.5	92.6	92.7	93.0	92.4	92.5	92.5	92.8	
kW Input	270	287	296	295	293	310	322	322	316	333	345	344	325	342	359	358	

DIMENSIONS

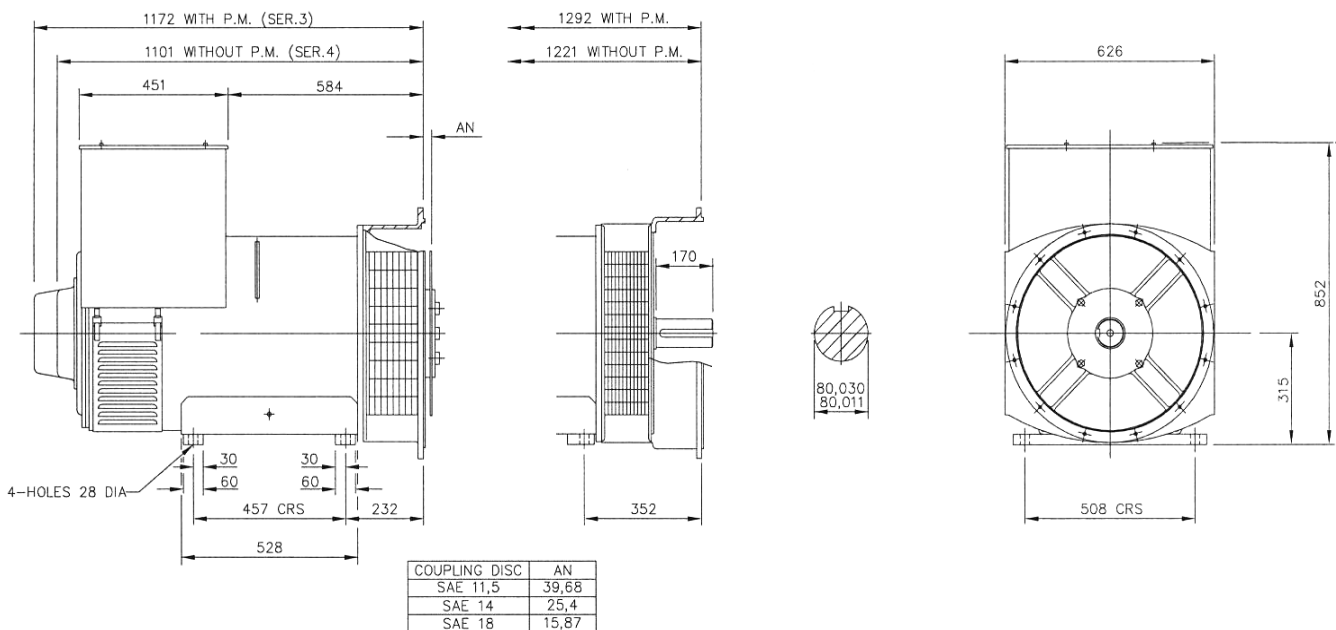

Barnack Road • Stamford • Lincolnshire • PE9 2NB
Tel: 00 44 (0)1780 484000 • Fax: 00 44 (0)1780 484100
Website: www.newage-avkseg.com