



ottomotores

CUMMINS SERIE QSX

Energía que Mueve al Mundo

Definiciones

Potencia Prime

Estos valores son aplicables para el suministro de energía eléctrica continua (a carga variable) en lugar de la red comercial + 10% sobrecarga

Potencia Stand by

Estos valores son aplicables para el suministro de energía eléctrica continua (con carga variable) en caso de falla de la red comercial. No se permite sobrecarga sobre estos valores.

Tabla de Potencias

Modelo	Voltaje	kVA Prime	kWe Prime	kVAStand-by	kWe Stand-by
CNY450	220-440V	511	409	563	450
CNY500	220-440V	568	455	625	500

0.8 Factor de potencia

Información Técnica

Datos Técnicos	CNY450	CNY500
Frecuencia:	60 Hz	60 Hz
Marca / Modelo	QSX15G7	QSX15G9
Generador Modelo:	Stamford HCI534C	Stamford HCI534D
Número de Cilindros:	6 en línea	6 en línea
Diámetro por Carrera :in (mm)	5.39X6.65 (137X169)	5.39X6.65 (137X169)
Relación de Compresión:	17.0 : 1	17.0 : 1
Aspiración:	turbo y postenfriado	turbo y postenfriado
Velocidad:	1800 RPM	1800 RPM
Potencia: BHP(kWm)	685 (511)	750 (560)
Presion Efectiva: psi (kPA)	330 (2275)	360 (2508)
Velocidad dePiston: ft/min (m/s)	1995 (10.1)	1995 (10.1)
Consumo a plena carga: lt / hr - 100%	120.00	135.90
Calor Expulsado en el Sistema de Escape: BTU/min (kWm)	21600(380)	24400 (429)
Calor Expulsado en el Sistema de Enfriamiento: BTU/min (kWm)	7830 (137)	9070 (159)
Temperatura de Escape: °F (°C)	909 (487)	909 (488)
Fujo de Enfriamiento en el Radiador m³/seg - FPM	llame a fabrica	llame a fabrica
Fujo de Escape: cfm (liter/s)	3235 (1527)	3845 (1815)



Nota: Imagen de carácter ilustrativa ya que los equipos en foto pudieran incluir accesorios opcionales

Como leer nuestro codigo: Ejem: **CNY300**

C=Motor Cummins
N=Generador Newage Stamford
Y=60Hz-1800 RPM
300= Potencia del Equipo.



Ottomotores, S.A de C.V.

Calz. San Lorenzo No.1150
Col. Cerro de la estrella, C.P. 09860
Delg. Iztapalapa México, D.F.
Tels:52-55-5624-5600

Fax: 52-55-5426-5521 / 52-55-5426-5581
email: ventas@ottomotores.com.mx

sitio web: www.ottomotores.com.mx

Dimensiones



Tabla de Dimensiones

CNY450 CNY500	Equipo con Base Estructural			Equipo con Base Tanque			Equipo con Caseta Acústica*		
	A	B	C	x	y	z	D	E	F
G-drive	345,00	155,00	230,00	381,00	175,00	231,00	500,00	175,00	250,00
	Peso: 3295,00 kgs			Peso: 3780,00 kgs			Peso: 5379,00 kgs		

[*] Equipo opcional

Información Técnica

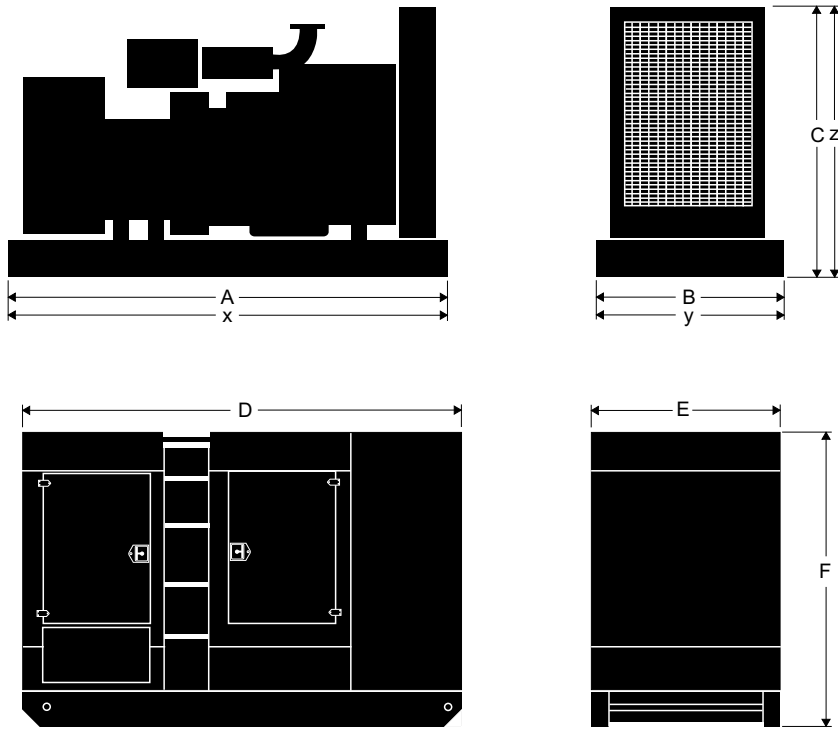
Nota: las condiciones de referencia estándar son de 25 °C (77 ° F) temperatura de entrada de aire. Todos los datos de desempeño de motores son basados en la potencia mencionada arriba.

Datos de consumo de combustible a plena carga con combustible diesel tienen una gravedad específica de 0,85.

Comercializado por:

Módulos de Control



Ottomotores tiene una posición única en la fabricación de grupos electrógenos utilizando en ellos módulos de control que cumplen con todos los niveles de requerimiento del mercado nacional y de exportación.



Las diferentes soluciones de controles que se tienen para nuestra gama de plantas generadoras, permite una operación simple en modo manual y automático, así mismo permiten desarrollar proyectos de sincronía entre plantas generadoras o con la red de energía eléctrica.



La familia de módulos de control en transición abierta (DALE 3200) permite tener control en forma automática de la unidad de transferencia, así como el monitoreo del grupo generador.



Nuestro módulos de control cuentan con puerto de comunicación RS485 para la comunicación remota con el grupo generador.



Los módulos pueden ser monitoreados através de un excelente software para observar parámetros del equipo de manera fácil y rápida.

La familia de módulos de control para la sincronía (6100, 6050 y 6300), incorporan un amplio sistema de monitoreos además de conexión a Internet (LAN) o mensaje SMS vía celular, o usando los puertos de comunicación RS485 a través de ModBus



ottomotores

Energía que Mueve al Mundo

Calz. San Lorenzo No.1150
Col. Cerro de la Estrella, C.P.09860
Delegación Iztapalapa México D.F.
Tels: 52-55-5624-5600
Fax.52-55-5426-55-21 / 52-55-54265581

E-mail ventas1@ottomotores.com.mx
ventas2@ottomotores.com.mx

Web site. www.ottomotores.com.mx

- MODELS
- CNE405
 - CNE455
 - CNE495
 - CNE530
 - CNE570
 - CNY450
 - CNY500
 - CNY446
 - CNY450
 - CNY500

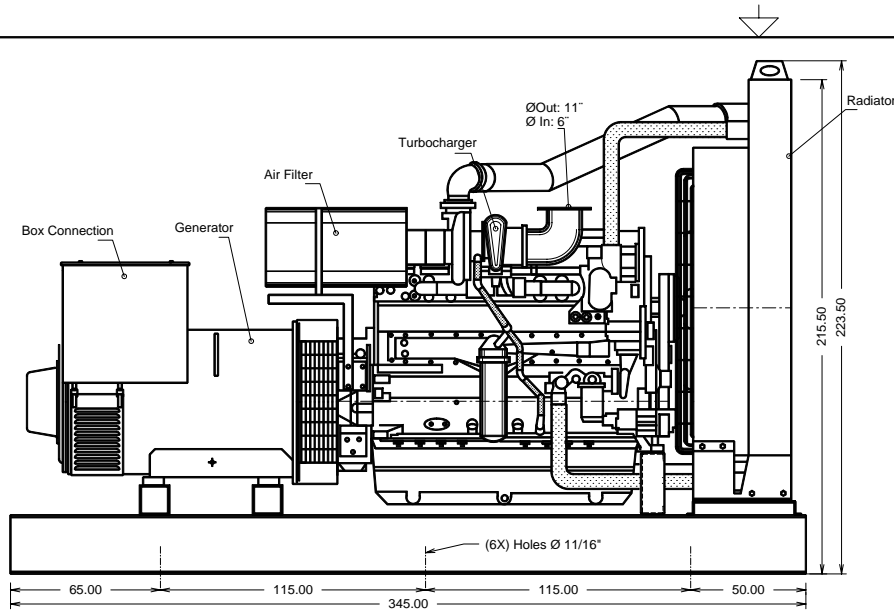

SIDE VIEW

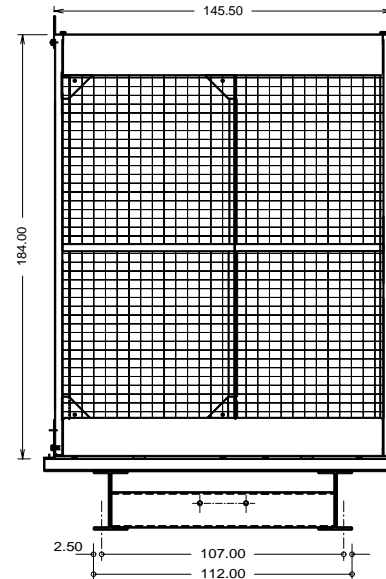

FRONT VIEW

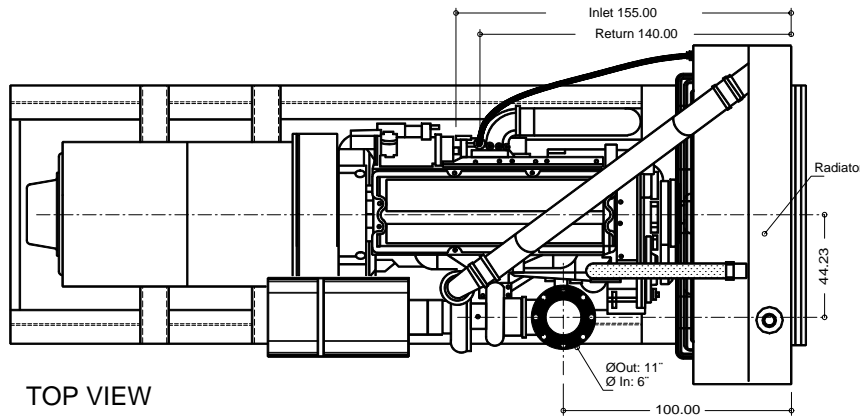

TOP VIEW

DESCRIPTION	
RADIATOR:	OT10/500
ENGINE:	QSX15G4/G6/G7/G8/G9
AIR: FILTER	AH1135
BASE FRAME:	BP-QSXG7-STF
# SPRING AVMS:	6 PZS

-THE GENSET DIMENSIONS ARE THE SAME BY FAMILY MODEL, THERE COULD BE ONLY DIFFERENCES ON THE ALTERNATOR LENGTH SEE SPECIFIC GENERAL ARRANGEMENT DRAWING OF CERTAIN MODEL
 -TOTAL WEIGHT COULD VARY CHECK RATING CHART FOR EACH MODEL

Customer: _____ S/O: _____

Rev.	Description	Date	Certified

Title: **CUMMINS ENGINE QSX15G4/G6/G7/G8/G9 - STAMFORD ALTERNATOR**

Draw: R.G.C. Revised: F.H.M. Certificated: F.H.M. Code: **CNEY-11**

Date: JAN 05th 2005 Date: JAN 05th 2005 Date: JAN 05th 2005 Dept.: Engineering

Marks: cms Draw: _____

Scale: s/e Of: _____

Reviews

Otomotors keeps the right to change the information with out prior notice



Cummins Inc.

Columbus, Indiana 47201

Engine Data Sheet

Basic Engine Model:
QSX15-G9 Nonroad 2

Curve Number:
FR-10441

G-DRIVE
QSX
1

Engine Critical Parts List:
CPL: 8142

Date:
4Mar02

Displacement : 15 liter (912 in³)

Bore : 137 mm (5.39 in.) Stroke : 169 mm (6.65 in.)

No. of Cylinders : 6

Aspiration : Turbocharged and Charge Air Cooled

Engine Speed	Standby Power		Prime Power		Continuous Power	
	kWm	BHP	kWm	BHP	kWm	BHP
1800	560	750	507	680	354	475

Engine Performance Data @ 1800 RPM

OUTPUT POWER			FUEL CONSUMPTION			
%	kWm	BHP	kg/kWm-h	lb/BHP-h	liter/hour	U.S. Gal/hour
STANDBY POWER						
100	560	750	0.207	0.340	135.9	35.9
PRIME POWER						
100	507	680	0.198	0.325	117.8	31.1
75	380	510	0.202	0.333	90.5	23.9
50	254	340	0.219	0.360	65.3	17.2
25	127	170	0.251	0.413	37.4	9.9
CONTINUOUS POWER						
100	354	475	0.205	0.337	85.3	22.5

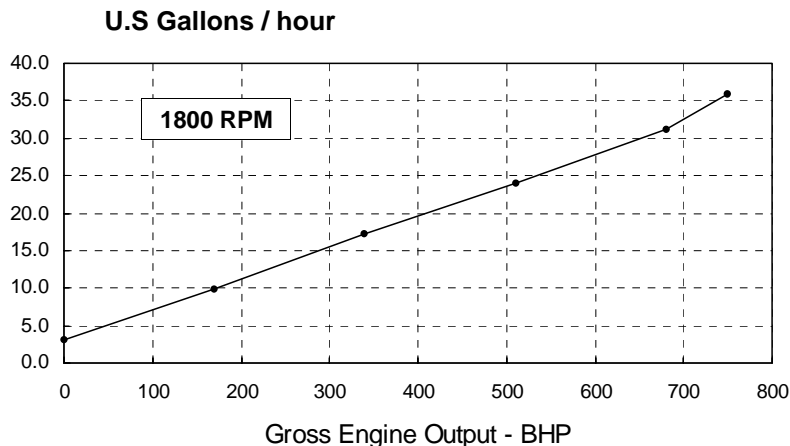

Power Derate Curves:

Standby / Prime Power

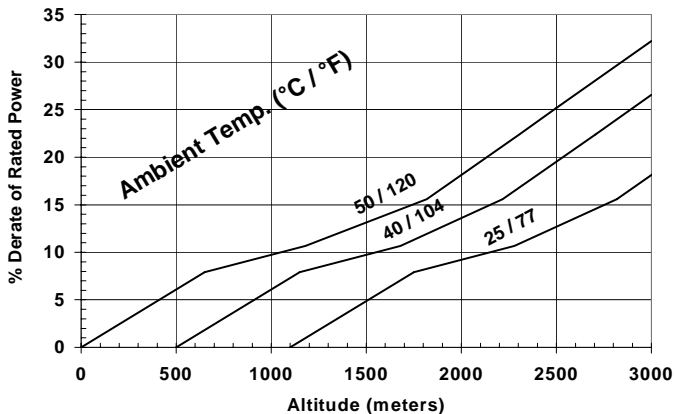

Continuous Power

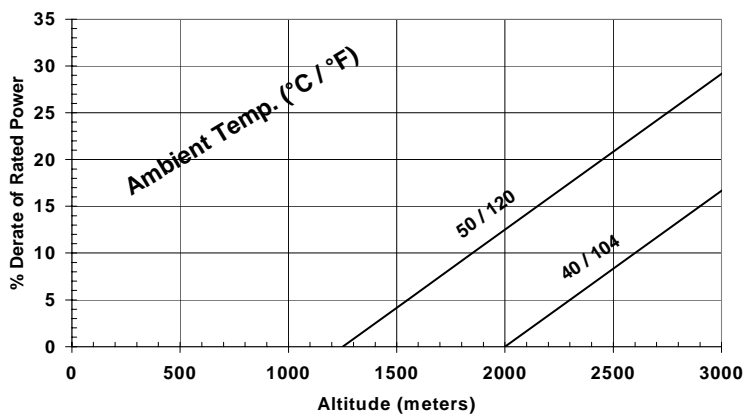

Operation At Elevated Temperature And Altitude:

For sustained operation above these conditions, derate by an additional 1.8% per 300 m (1000 ft), and 10% per 10° C (18° F).

CONVERSIONS:(Liters = U.S. Gal x 3.785) (U.S.Gal = Liters x 0.2642)

Data Subject to Change Without Notice

These guidelines have been formulated to ensure proper application of generator drive engines in A.C. generator set installations. **STANDBY POWER RATING:** Applicable for supplying emergency power for the duration of the utility power outage. No overload capability is available for this rating. Under no condition is an engine allowed to operate in parallel with the public utility at the Standby Power rating. This rating should be applied where reliable utility power is available. A Standby rated engine should be sized for a maximum of an 80% average load factor and 200 hours of operation per year. This includes less than 25 hours per year at the Standby Power rating. Standby ratings should never be applied except in true emergency power outages. Negotiated power outages contracted with a utility company are not considered an emergency. **PRIME POWER RATING:** Applicable for supplying electric power in lieu of commercially purchased power. Prime Power applications must be in the form of one of the following two categories: **UNLIMITED TIME RUNNING PRIME POWER:** Prime Power is available for an unlimited number of hours per year in a variable load application. Variable load should not exceed a 70% average of the Prime Power rating during any operating period of 250 hours. The total operating time at 100% Prime Power shall not exceed 500 hours per year. A 10% overload capability is available for a period of 1 hour within a 12-hour period of operation. Total operating time at the 10% overload power shall not exceed 25 hours per year. **LIMITED TIME RUNNING PRIME POWER:** Limited Time Prime Power is available for a limited number of hours in a non-variable load application. It is intended for use in situations where power outages are contracted, such as in utility power curtailment. Engines may be operated in parallel to the public utility up to 750 hours per year at power levels never to exceed the Prime Power rating. The customer should be aware, however, that the life of any engine will be reduced by this constant high load operation. Any operation exceeding 750 hours per year at the Prime Power rating should use the Continuous Power rating. **CONTINUOUS POWER RATING:** Applicable for supplying utility power at a constant 100% load for an unlimited number of hours per year. No overload capability is available for this rating.

Reference AEB 10.47 for determining Electrical Output.

Data shown above represent gross engine performance capabilities obtained and corrected in accordance with ISO-3046 conditions of 100 kPa (29.53 in Hg) barometric pressure [110 m (361 ft) altitude], 25 °C (77 °F) air inlet temperature, and relative humidity of 30% with No. 2 diesel or a fuel corresponding to ASTM D2. Derates shown are based on 15 in H₂O air intake restriction and 2 in Hg exhaust back pressure.

The fuel consumption data is based on No. 2 diesel fuel weight at 0.85 kg/liter (7.1 lbs/U.S. gal). Power output curves are based on the engine operating with fuel system, water pump and lubricating oil pump; not included are battery charging alternator, fan, optional equipment and driven components.

Data Status: Limited Production
Data Tolerance: ± 5%

Chief Engineer:
D.K. Trueblood

Cummins Inc.

Engine Data Sheet

ENGINE MODEL : QSX15-G9 Nonroad 2

CONFIGURATION NUMBER : D103003GX03

DATA SHEET : DS-10441

DATE : 4Mar02

PERFORMANCE CURVE : FR-10441

INSTALLATION DIAGRAM

• Fan to Flywheel : 3170370

CPL NUMBER

• Engine Critical Parts List : 8142

GENERAL ENGINE DATA

Type	4 Cycle; In-line; 6-Cylinder Diesel
Aspiration	Turbocharged and Charge Air Cooled
Bore x Stroke	5.39 x 6.65 (137 x 169)
Displacement	912 (15)
Compression Ratio	17 : 1
Dry Weight	3020 (1370)
Wet Weight	3250 (1475)
Moment of Inertia of Rotating Components	
• with FW 1022 Flywheel	106.7 (4.5)
• with FW 1025 Flywheel	192.0 (8.1)
Center of Gravity from Front Face of Block	19 (483)
Center of Gravity above Crankshaft Centerline	10 (255)
Maximum Static Loading at Rear Main Bearing	5400 (2450)

ENGINE MOUNTING

Maximum Bending Moment at Rear Face of Block	1500 (2034)
--	-------------

EXHAUST SYSTEM

Maximum Back Pressure at Standby Power Rating	3 (76)
Maximum Bending Moment to the Turbo Flange	11 (15)

AIR INDUCTION SYSTEM

Maximum Temperature Rise Between Engine Air Inlet and Intake Manifold	43 (24)
Maximum Intake Air Restriction Including Air Filter Plumbing	
• with Dirty Filter Element	25 (635)
• with Clean Filter Element	15 (381)
Maximum Allowable Pressure Drop from Turbo Outlet to Intake Manifold	4 (102)

COOLING SYSTEM

Coolant Capacity — Engine Only	25 (24)
Maximum Coolant Friction Head External to Engine	
— 1800 rpm	10 (69)
— 1500 rpm	8 (55)
Maximum Static Head of Coolant Above Engine Crank Centerline	46 (14)
Standard Thermostat (Modulating) Range	180 - 200 (82 - 93)
Minimum Pressure Cap	10 (70)
Maximum Top Tank Temperature for Standby / Prime Power	230 / 220 (110 / 104)

LUBRICATION SYSTEM

Oil Pressure @ Idle Speed (Minimum)	20 (138)
@ Pressure Range — Cold	Up to 130 (Up to 900)
— Warm	35 - 40 (242 - 276)
Maximum Oil Temperature	250 (121)
Oil Capacity with OP 1493 Oil Pan : High - Low	22 - 19 (83 - 72)
Total System Capacity (Including Filter)	24 (91)
Angularity of OP 1493 Oil Pan — Front Down	5°
— Front Up	15°
— Side to Side	15°

FUEL SYSTEM

Type Injection System	Cummins HPI-TP
Maximum Restriction at OEM Inlet Connection..... — in Hg (mm Hg)	5.0 (127)
Maximum Allowable Head on Injector Return Line (Consisting of Friction Head and Static Head)..... — in Hg (mm Hg)	6.5 (165)
Maximum Fuel Flow to Injection Pump	112 (424)
Maximum Fuel Inlet Temperature..... — °F (°C)	160 (71)
Maximum Return Fuel Flow	102 (386)
Maximum Return Fuel Temperature @ 160°F (71°C) Fuel Inlet Temperature	210 (99)
Minimum Fuel Tank Vent Capability..... — cfm (liter / s)	1.2 (.55)

ELECTRICAL SYSTEM

Cranking Motor (Heavy Duty, Positive Engagement)..... — volt	24
Maximum Allowable Resistance of Cranking Circuit..... — ohm	0.002
Minimum Recommended Battery Capacity	
• Cold Soak @ 50 °F (10 °C) and Above..... — °F CCA	600
• Cold Soak @ 32 °F to 50 °F (0 °C to 10 °C)..... — °F CCA	640
• Cold Soak @ 0 °F to 32 °F (-18 °C to 0 °C)..... — °F CCA	900

COLD START CAPABILITY

Minimum Ambient Temperature for Cold Start with Coolant Heater to Rated Speed	7	(-14)
Minimum Ambient Temperature for Unaided Cold Start to Low Idle Speed.....	25	(-4)
Minimum Ambient Temperature for NFPA 110 Cold Start (90°F minimum coolant temperature).....	32	(0)

PERFORMANCE DATA

- All data is based on:
- Engine operating with fuel system, water pump, lubricating oil pump, air cleaner and exhaust silencer; not included are battery charging alternator, fan, and optional driven components.
 - Engine operating with fuel corresponding to grade No. 2-D per ASTM D975.
 - ISO 3046, Part 1, Standard Reference Conditions of:

Barometric Pressure	: 100 kPa (29.53 in Hg)	Air Temperature	: 25 °C (77 °F)
Altitude	: 110 m (361 ft)	Relative Humidity	: 30%

Steady State Stability Band at any Constant Load	— %	+/- 0.25%
Estimated Free Field Sound Pressure Level of a Typical Generator Set;		
Excludes Exhaust Noise; at Rated Load and 7.5 m (25 ft); 1800 rpm / 1500 rpm	— dBA	89.0 / 89.5
Exhaust Noise at 1 m Horizontally from Centerline of Exhaust Pipe Outlet Upwards at 45°; 1800 rpm / 1500 rpm	— dBA	125 / 123

Governed Engine Speed	— rpm
Engine Idle Speed.....	— rpm
Gross Engine Power Output.....	— BHP (kW _m)
Brake Mean Effective Pressure.....	— psi (kPa)
Piston Speed.....	— ft / min (m / s)
Friction Horsepower.....	— HP (kW _m)
Engine Water Flow at Stated Friction Head External to Engine:	
• 3 psi Friction Head.....	— US gpm (liter / s)
• Maximum Friction Head	— US gpm (liter / s)
Turbo Compressor Outlet Pressure.....	— psi (kPa)
Turbo Compressor Outlet Temperature	— °F (°C)
Intake Air Flow.....	— cfm (liter / s)
Exhaust Gas Temperature	— °F (°C)
Exhaust Gas Flow	— cfm (liter / s)
Air-to-Fuel Ratio	— air : fuel
Radiated Heat to Ambient	— BTU / min (kW _m)
Heat Rejection to Coolant.....	— BTU / min (kW _m)
Heat Rejection to Exhaust.....	— BTU / min (kW _m)
Heat Rejection to Fuel *.....	— BTU / min (kW _m)
Heat Rejection to Aftercooler.....	— BTU / min (kW _m)

STANDBY		PRIME POWER	
60 hz	50 hz	60 hz	50 hz
1800		1800	
675 - 775		675 - 775	
750 (560)		680 (507)	
360 (2508)		327 (2268)	
1995 (10.1)		1995 (10.1)	
70 (52)		70 (52)	
	Not Available at 1500 RPM (50 hz)		Not Available at 1500 RPM (50 hz)
105 (6.6)		105 (6.6)	
87 (5.5)		87 (5.5)	
42.7 (294)		37.4 (258)	
440 (226)		400 (204)	
1510 (712)		1380 (651)	
909 (488)		875 (468)	
3845 (1815)		3200 (1510)	
26.6 : 1		27.8 : 1	
2070 (36)		2410 (42)	
9230 (162)		7830 (138)	
24400 (429)		21600 (380)	
450 (8)		450 (8)	
9070 (159)		7300 (128)	

* Maximum heat rejection which occurs at rated speed, no load.

N.A. - Data is Not Available
N/A - Not Applicable to this Engine
TBD - To Be Determined

ENGINE MODEL : QSX15-G9 Nonroad 2
DATA SHEET : DS-10441
DATE : 4Mar02
CURVE NO. : FR-10441

Cummins Inc.

Columbus, Indiana 47202-3005

• Limited Production •

FRAME HC534D/544D HCK534D/544D

WINDING 311

RATINGS	REFER TO RATINGS BOOK
OVERLOAD	REFER TO RATINGS BOOK
ALTITUDE	REFER TO RATINGS BOOK
AMBIENT TEMP.	REFER TO RATINGS BOOK

CONTROL SYSTEM SER. 3	SEPARATELY EXCITED BY P.M.G. FRAME DESIGNATION HC534		
A.V.R.	MX341	MX321	
VOLTAGE REGULATION	± 1.0%	± 0.5%	WITH 4% ENGINE GOVERNING
SUSTAINED SHORT CIRCUIT	REFER TO SHORT CIRCUIT DECREMENT CURVES OF THIS SECTION		

CONTROL SYSTEM SER. 4	SELF EXCITED FRAME DESIGNATION HC544		
A.V.R.	SX440	SX421	
VOLTAGE REGULATION	± 1.0%	± 0.5%	WITH 4% ENGINE GOVERNING
SUSTAINED SHORT CIRCUIT	SERIES 4 CONTROL DOES NOT SUSTAIN A SHORT CIRCUIT CURRENT		

INSULATION SYSTEM	CLASS H	
PROTECTION	IP22 STANDARD - IP23 OPTIONAL (5% DERATE)	
RATED POWER FACTOR	0.8	
STATOR WINDING	DOUBLE LAYER LAP	
WINDING PITCH	TWO THIRDS	
WINDING LEADS	12	
STATOR WDG. RESISTANCE	0.0057 Ohms PER PHASE AT 22°C SERIES STAR CONNECTED	
ROTOR WDG. RESISTANCE	1.77 Ohms at 22°C	
R.F.I. SUPPRESSION	BS EN 50081/2-1/2 VDE 0875G VDE 0875N For other standards apply to the factory	
WAVEFORM DISTORTION	NO LOAD < 1.5 % NON-DISTORTING BALANCED LINEAR LOAD < 5.0 %	
MAXIMUM OVERSPEED	2250 Rev/Min	
BEARING DRIVE END HC ONLY	BALL. 6220 (ISO)	
BEARING NON-DRIVE END	BALL. 6314 (ISO)	
EFFICIENCY	REFER TO EFFICIENCY CURVES OF THIS SECTION	
	1 BEARING	2 BEARING HC ONLY
WEIGHT COMP. GENERATOR	1395 kg	1395 kg
WEIGHT WOUND STATOR	657 kg	657 kg
WEIGHT WOUND ROTOR	565 kg	534 kg
WR ² INERTIA	8.03 kgm ²	7.73 kgm ²

	50 Hz				60 Hz			
TELEPHONE INTERFERENCE	THF < 2%				TIF < 50			
COOLING AIR FOR HC	1.035 m ³ /sec 2202 cfm				1.312 m ³ /sec 2780 cfm			
COOLING AIR FOR HCK	1.23 m ³ /sec 2615 cfm				1.59 m ³ /sec 3366 cfm			
VOLTAGE SERIES STAR (Y)	380/220	400/231	415/240	440/254	416/240	440/254	460/266	480/277
VOLTAGE PARALLEL STAR (Y)	190/110	200/115	208/120	220/127	208/120	220/127	230/133	240/138
VOLTAGE EDISON DELTA (Δ)	220/110	230/115	240/120	250/125	240/120	254/127	266/133	277/138
KVA BASE RATING FOR REACTANCE VALUES	500	500	500	500	575	594	625	644
X _d DIR. AXIS SYNCHRONOUS	3.03	2.73	2.53	2.25	3.52	3.25	3.13	2.96
X' _d DIR. AXIS TRANSIENT	0.16	0.14	0.13	0.12	0.17	0.16	0.16	0.14
X'' _d DIR. AXIS SUBTRANSIENT	0.11	0.10	0.09	0.08	0.12	0.11	0.11	0.10
X _q QUAD. AXIS REACTANCE	2.48	2.16	2.08	1.85	2.87	2.65	2.55	2.41
X'' _q QUAD. AXIS SUBTRANSIENT	0.27	0.25	0.23	0.20	0.31	0.29	0.28	0.26
X _L LEAKAGE REACTANCE	0.05	0.05	0.04	0.04	0.06	0.06	0.05	0.05
X ₂ NEGATIVE SEQUENCE	0.19	0.17	0.16	0.14	0.22	0.20	0.20	0.19
X ₀ ZERO SEQUENCE	0.10	0.09	0.08	0.07	0.10	0.10	0.09	0.09
REACTANCES ARE SATURATED				VALUES ARE PER UNIT AT RATING AND VOLTAGE INDICATED				
T' _d TRANSIENT TIME CONST.	0.08 sec							
T'' _d SUB-TRANSTIME CONST.	0.012 sec							
T' _{do} O.C. FIELD TIME CONST.	2.20 sec							
T _a ARMATURE TIME CONST.	0.018 sec							
SHORT CIRCUIT RATIO	1/X _d							

**SERIES 3 WINDING 311
LOCKED ROTOR MOTOR STARTING CURVE**

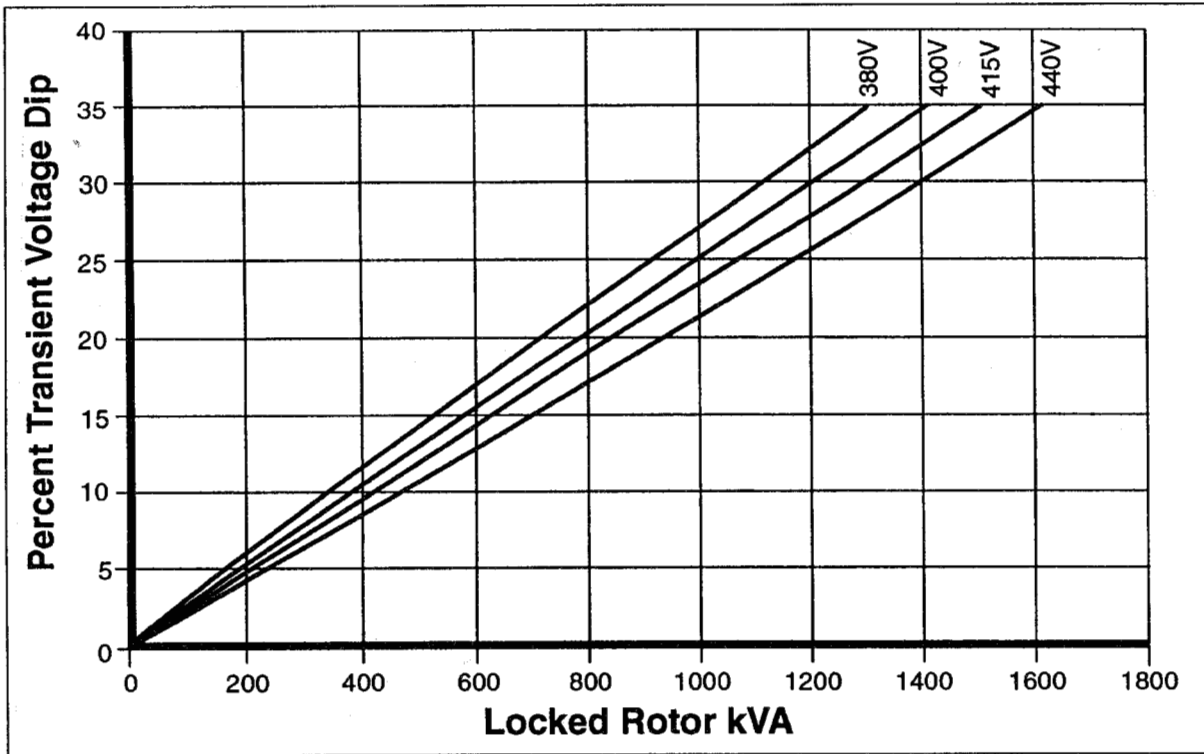

**SERIES 3 WINDING 311
LOCKED ROTOR MOTOR STARTING CURVE**

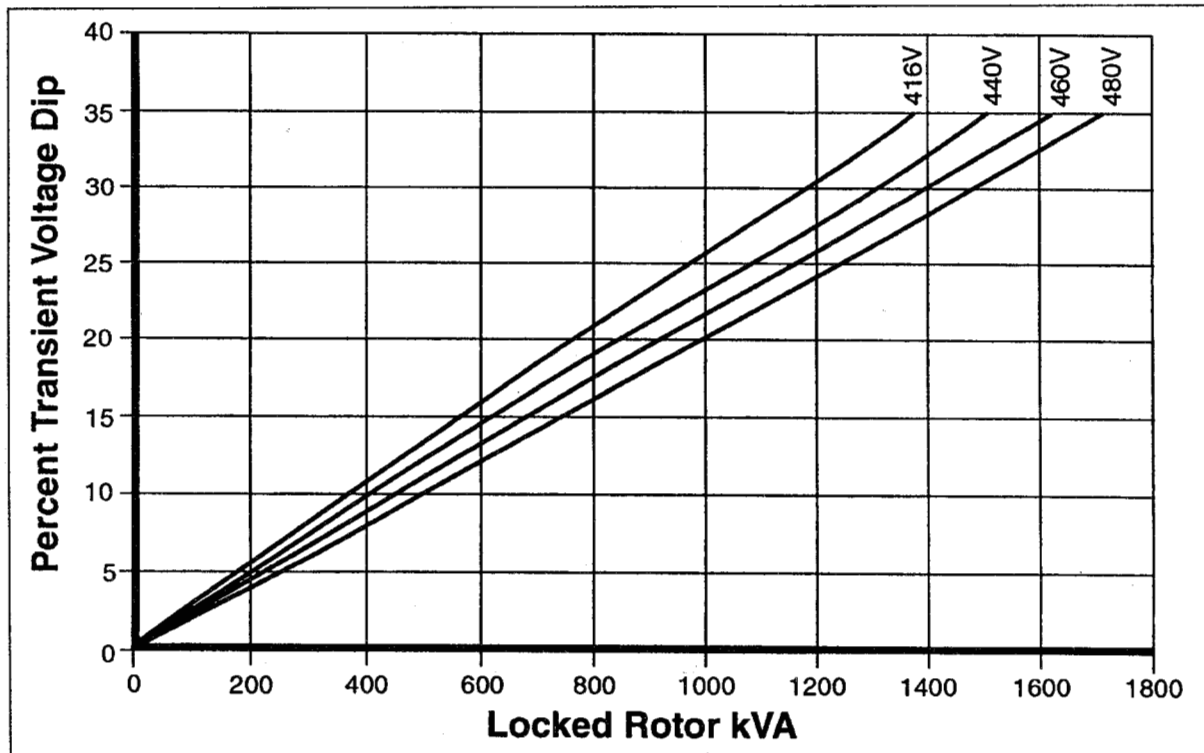

**SERIES 4 WINDING 311
LOCKED ROTOR MOTOR STARTING CURVE**

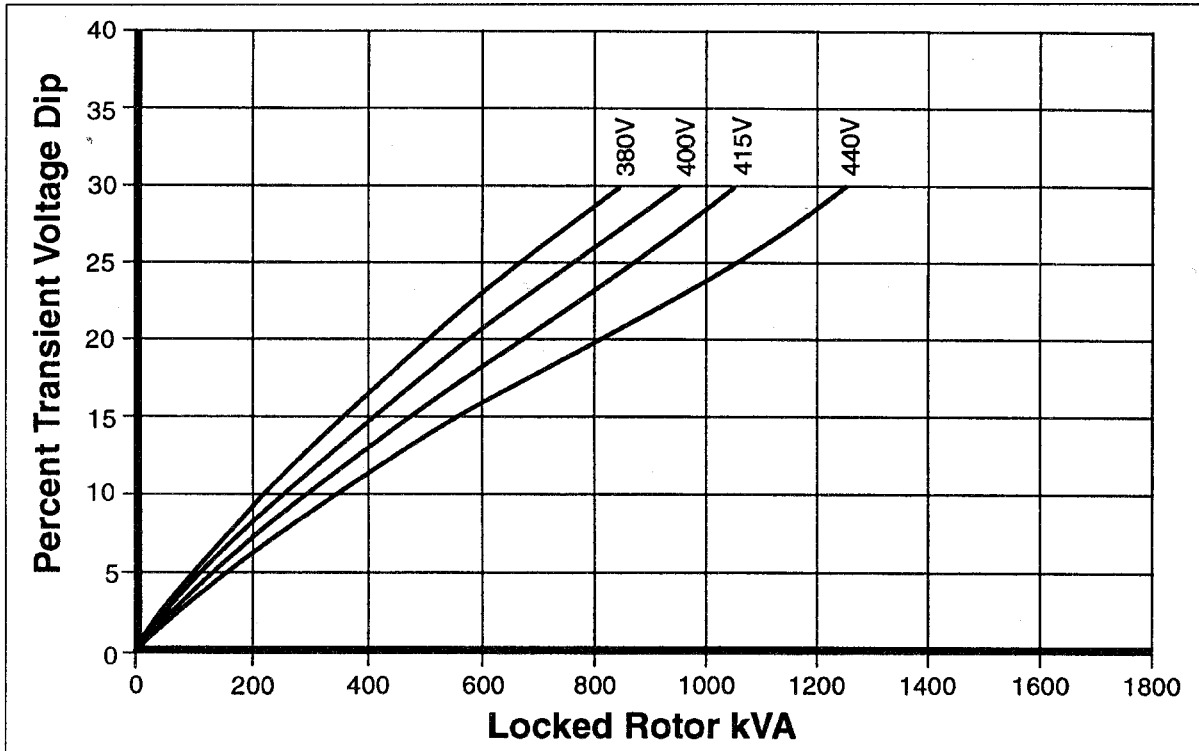

**SERIES 4 WINDING 311
LOCKED ROTOR MOTOR STARTING CURVE**

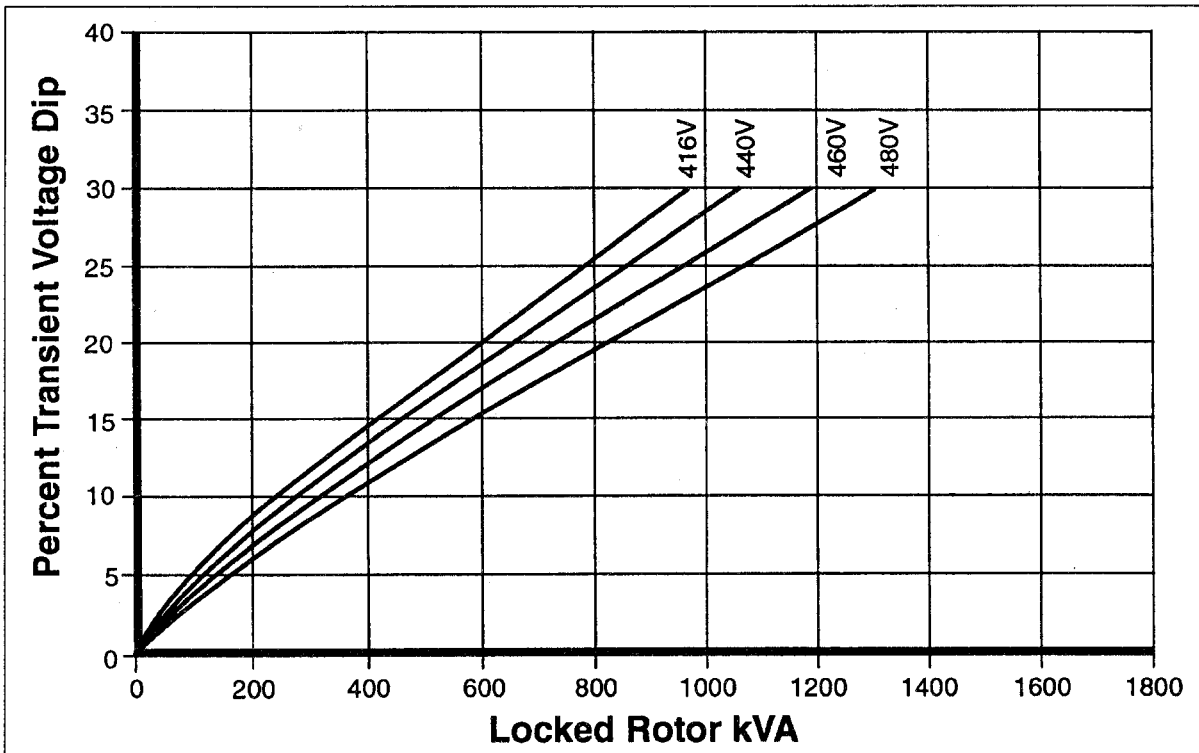

THREE PHASE EFFICIENCY CURVES

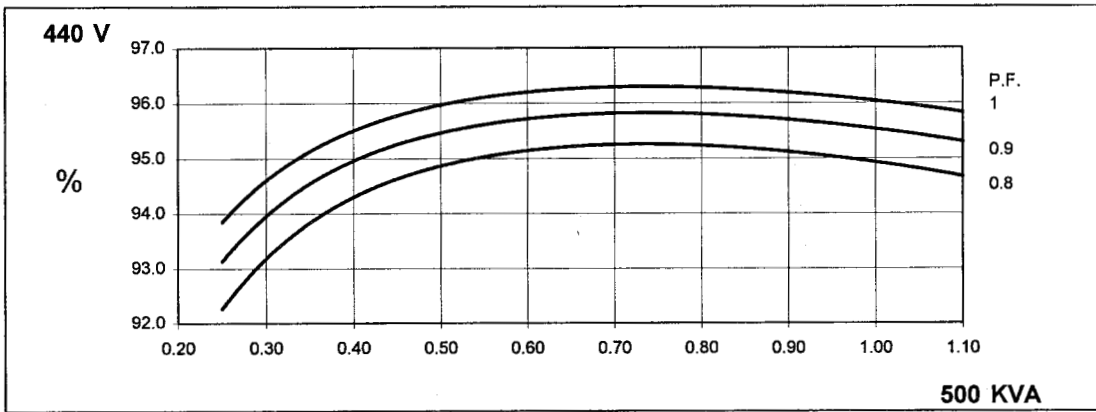
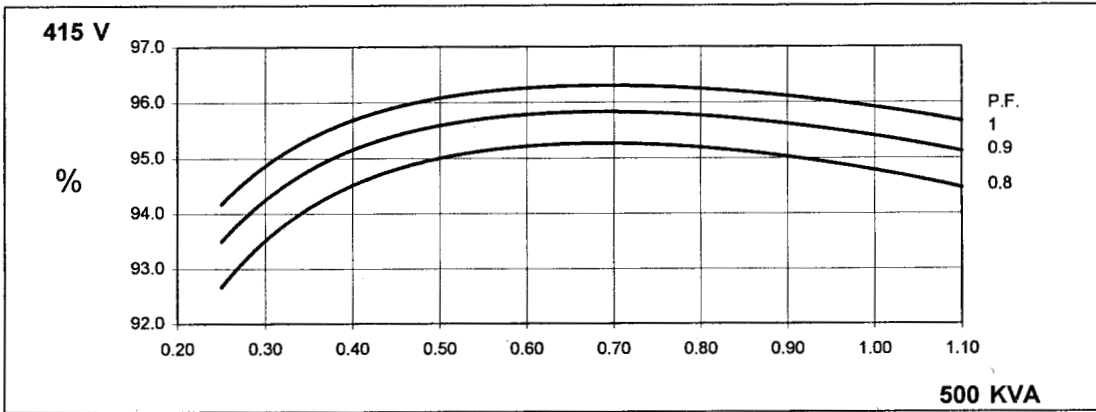
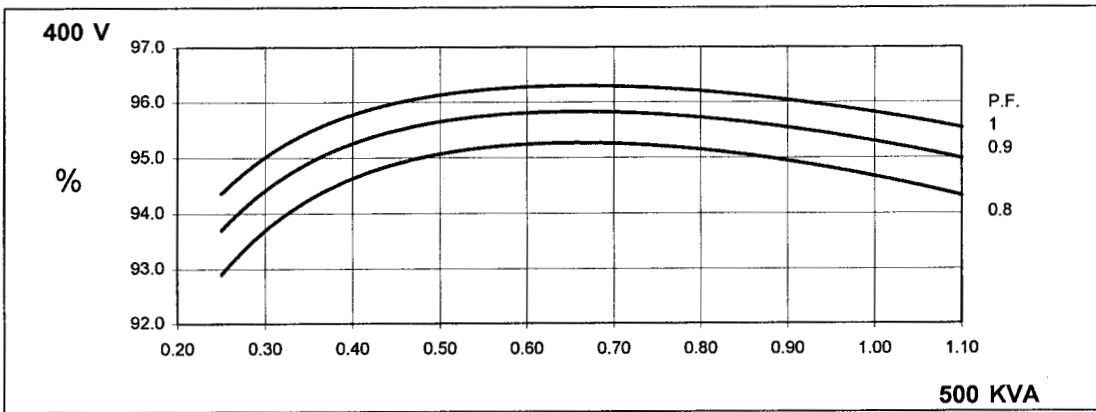
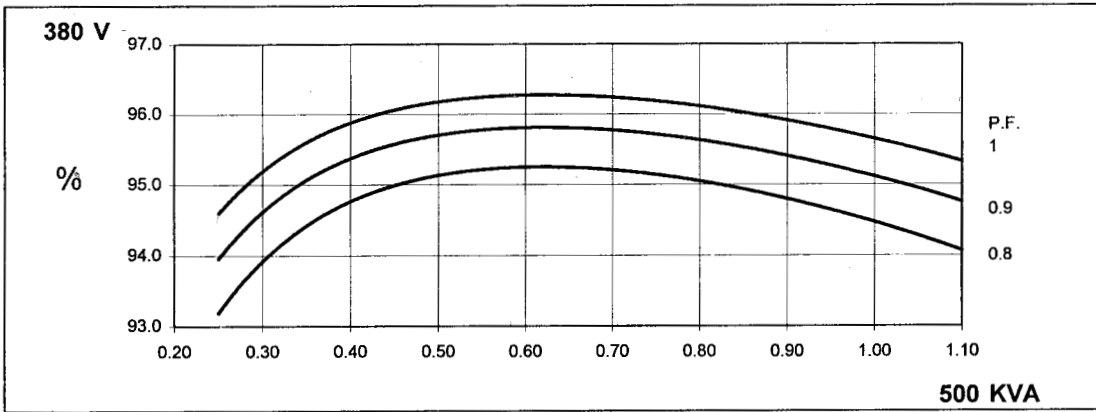

THREE PHASE EFFICIENCY CURVES

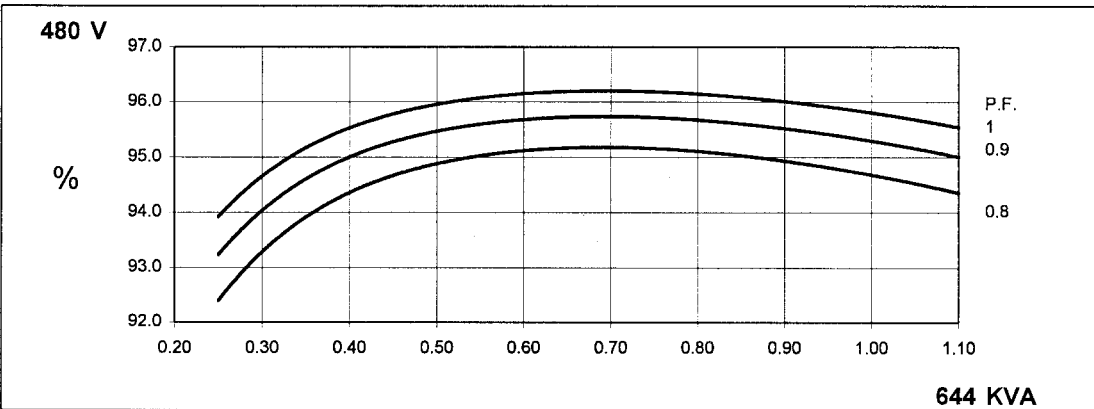
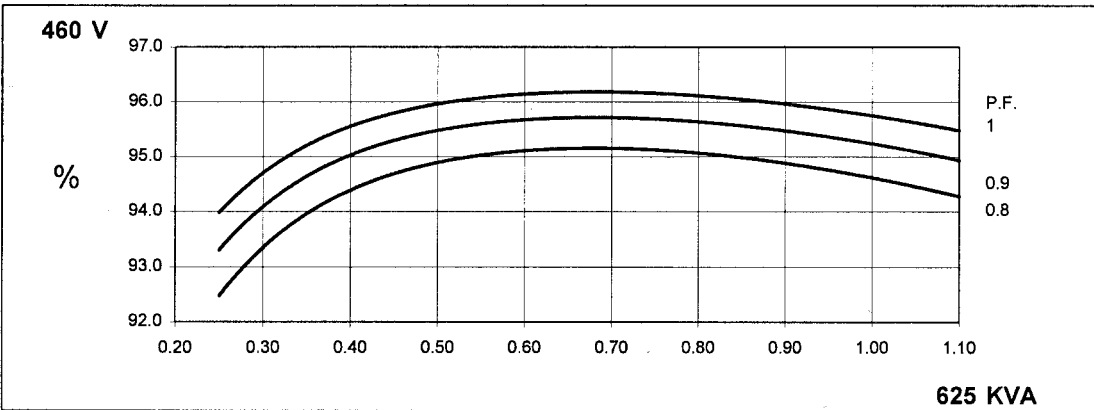
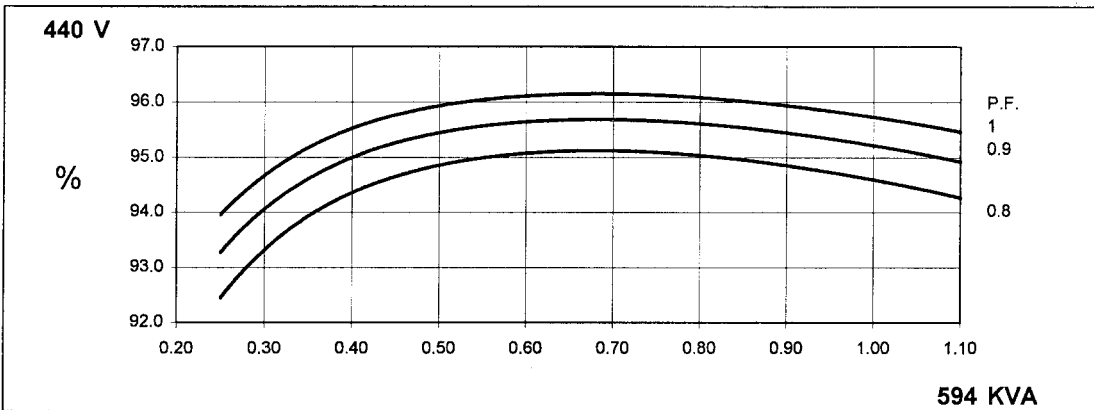
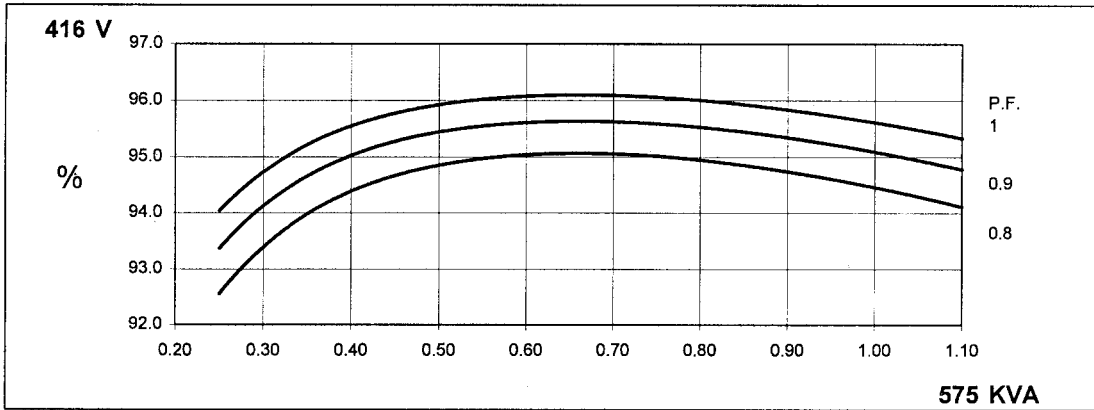

FRAME HC534D HCK534D 50 Hz

SERIES THREE Three Phase Short Circuit Decrement Curve No-load Excitation at Rated Speed

Based on series star (wye) connection

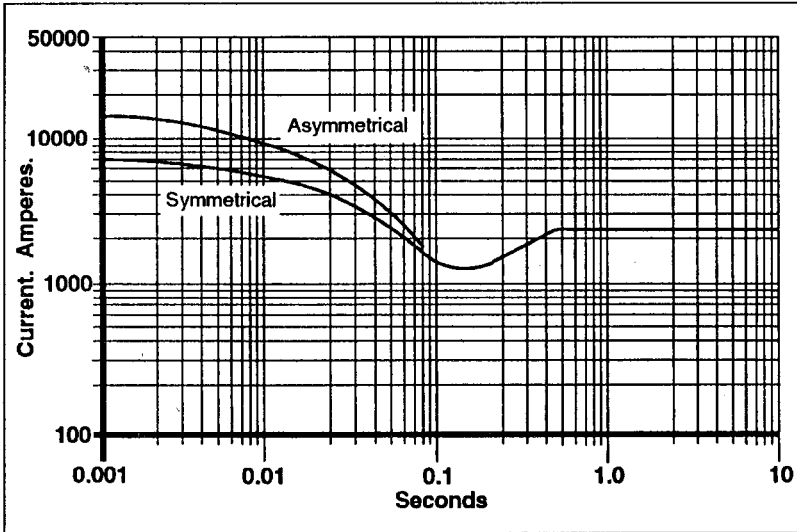

Note 1

The following multiplication factors should be used to adjust the values from curve between time 0.001 seconds and the minimum current point in respect of nominal operating voltage :

VOLTAGE	FACTOR
380 V	X 1.0
400 V	X 1.06
415 V	X 1.09
440 V	X 1.12

The sustained current value is constant irrespective of voltage level.

Note 2

The following multiplication factors should be used to convert the values calculated in accordance with NOTE 1 to those applicable to the various types of short circuit :

	3 PHASE	2 PHASE L-L	1 PHASE L-N
Instantaneous	X 1.00	X 0.87	X 1.30
Minimum	X 1.00	X 1.80	X 3.20
Sustained	X 1.00	X 1.50	X 2.50
Max. sustained duration	10 sec.	5 sec.	2 sec.

All other times are unchanged.

Note 3

Curves are drawn for Series Star (Wye) connected machines. For other connections the following multipliers should be applied to current values shown :

Parallel Star (Wye) Curve current value X 2
Series Delta (Δ) Curve current value X 1.732

Times are unchanged.

FRAME HC534D HCK534D 60 Hz

SERIES THREE Three Phase Short Circuit Decrement Curve No-load Excitation at Rated Speed

Based on series star (wye) connection

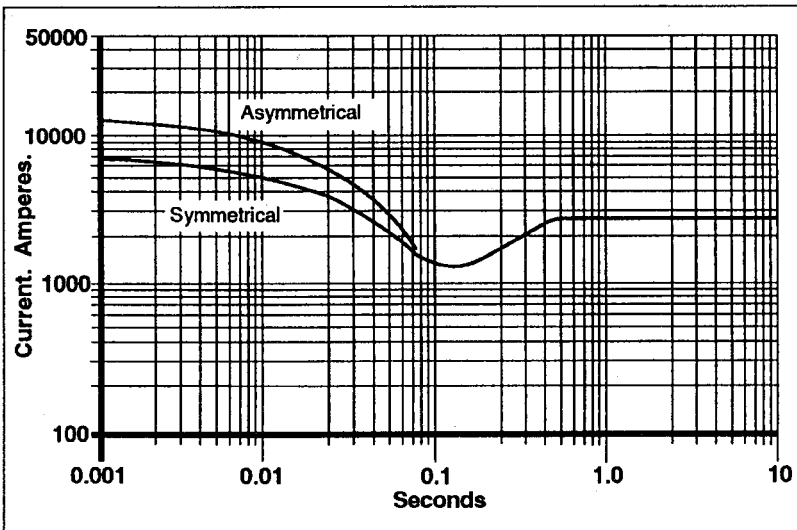

Note 1

The following multiplication factors should be used to adjust the values from curve between time 0.001 seconds and the minimum current point in respect of nominal operating voltage :

VOLTAGE	FACTOR
416 V	X 1.0
440 V	X 1.06
460 V	X 1.12
480 V	X 1.20

The sustained current value is constant irrespective of voltage level.

Note 2

The following multiplication factors should be used to convert the values calculated in accordance with NOTE 1 to those applicable to the various types of short circuit :

	3 PHASE	2 PHASE L-L	1 PHASE L-N
Instantaneous	X 1.00	X 0.87	X 1.30
Minimum	X 1.00	X 1.80	X 3.20
Sustained	X 1.00	X 1.50	X 2.50
Max. sustained duration	10 sec.	5 sec.	2 sec.

All other times are unchanged.

Note 3

Curves are drawn for Series Star (Wye) connected machines. For other connections the following multipliers should be applied to current values shown :

Parallel Star (Wye) Curve current value X 2
Series Delta (Δ) Curve current value X 1.732

Times are unchanged.

NEWAGE
INTERNATIONAL

NEWAGE INTERNATIONAL LIMITED
PO Box 17, Barnack Road, Stamford, Lincolnshire PE9 2NB, England.
Telephone 44 (0) 1780 484000
Telex 32268 Cables Newage Stamford Fax 44 (0) 1780 484100