



Energía que Mueve al Mundo



ottomotores

CUMMINS SERIE NTA

Definiciones

Potencia Prime

Estos valores son aplicables para el suministro de energía eléctrica continua (a carga variable) en lugar de la red comercial + 10% sobrecarga

Potencia Stand by

Estos valores son aplicables para el suministro de energía eléctrica continua (con carga variable) en caso de falla de la red comercial. No se permite sobrecarga sobre estos valores.

Tabla de Potencias

Modelo	Voltaje	kVA Prime	kWe Prime	kVA Stand-by	kWe Stand-by
CNY350	220-440V	398	318	438	350
CNY400	220-440V	455	364	500	400

0.8 Factor de potencia

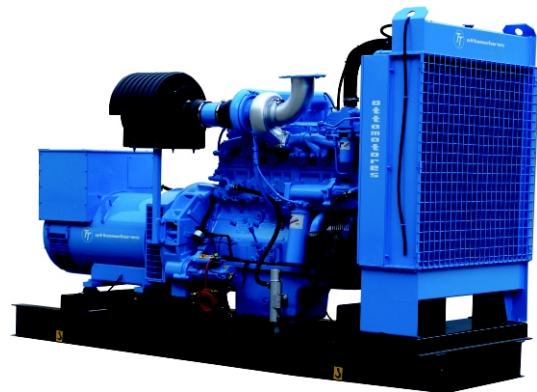

Información Técnica

Datos Técnicos	CNY350	CNY400
Frecuencia:	60 Hz	60 Hz
Marca / Modelo	NTA855G3	NTA855G5
Generador Modelo:	Stamford HCI434E	Stamford HCI434F
Número de Cilindros:	6 en línea	6 en línea
Diametro por Carrera :in (mm)	5.5X6.0 (140X152)	5.5X6.0 (140X152)
Relación de Compresión:	14.0:1	14.0:1
Aspiración:	turbo y postenfriado	turbo y postenfriado
Velocidad:	1800 RPM	1800 RPM
Potencia: BHP(kWm)	535 (399)	605 (451)
Presion Efectiva: psi (kPA)	275 (1896)	311 (2147)
Velocidad de Piston: ft/min (m/s)	1800 (9.1)	1800 (9.1)
Consumo a plena carga: lt / hr - 100%	96,00	110,00
Calor Expulsado en el Sistema de Escape: BTU/min (kWm)	15420 (271)	18520 (326)
Calor Expulsado en el Sistema de Enfriamiento: BTU/min (kWm)	13375 (235)	15125 (266)
Temperatura de Escape: °F (°C)	980 (527)	995 (535)
Flujo de Enfriamiento en el Radiador m ³ /seg - FPM	llame a fabrica	llame a fabrica
Flujo de Escape: cfm	3190 (1506)	3780 (1785)

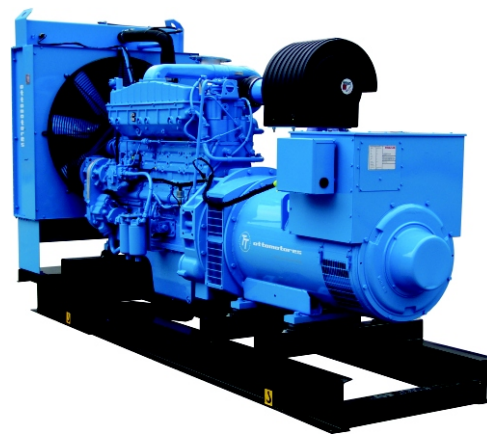

Nota: Imagen de carácter ilustrativa ya que los equipos en foto pudieran incluir accesorios opcionales

Como leer nuestro código: Ejem: CNY300

C=Motor Cummins
N=Generador Newage Stamford
Y=60Hz-1800 RPM
300= Potencia del Equipo.



Ottomotores, S.A de C.V.

Calz. San Lorenzo No.1150
Col. Cerro de la estrella, C.P. 09860
Delg. Iztapalapa México, D.F.
Tels:52-55-5624-5600

Fax: 52-55-5426-5521 / 52-55-5426-5581
email: ventas@ottomotores.com.mx

sitio web: www.ottomotores.com.mx

Dimensiones



Tabla de Dimensiones

CNY350	Equipo con Base Estructural			Equipo con Base Tanque			Equipo con Caseta Acústica*		
	A	B	C	x	y	z	D	E	F
	315,00	115,00	182,00	349,00	160,00	194,00			
	Peso: 3150,00 kgs			Peso: 3633,00 kgs			Peso: 4487,00kgs		

CNY400	Equipo con Base Estructural			Equipo con Base Tanque			Equipo con Caseta Acústica*		
	A	B	C	x	y	z	D	E	F
C.pack	315,00	115,00	182,00	349,00	160,00	194,00			
	Peso: 3297,00 kgs			Peso: 3780,00 kgs			Peso: 4634,00kgs		

[*] Equipo opcional

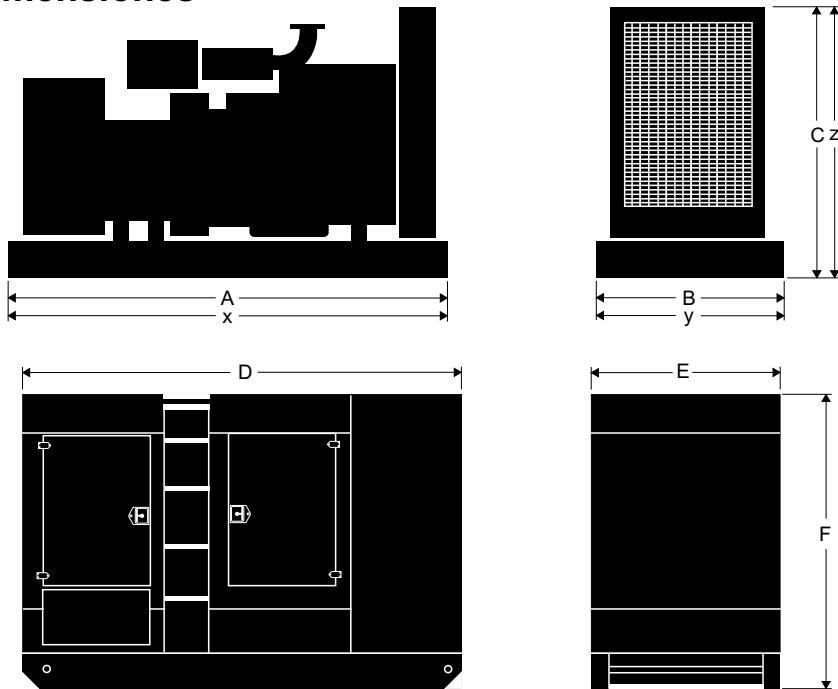
Información Técnica

Nota: las condiciones de referencia estándar son de 25 °C (77 ° F) temperatura de entrada de aire. Todos los datos de desempeño de motores son basados en la potencia mencionada arriba.

Datos de consumo de combustible a plena carga con combustible diesel tienen una gravedad específica de 0,85.

Comercializado por:

Módulos de Control



Ottomotors tiene una posición única en la fabricación de grupos electrógenos utilizando en ellos módulos de control que cumplen con todos los niveles de requerimiento del mercado nacional y de exportación.



Las diferentes soluciones de controles que se tienen para nuestra gama de plantas generadoras, permite una operación simple en modo manual y automático, así mismo permiten desarrollar proyectos de sincronía entre plantas generadoras o con la red de energía eléctrica.



La familia de módulos de control en transición abierta (DALE 3200) permite tener control en forma automática de la unidad de transferencia, así como el monitoreo del grupo generador.



Nuestro módulos de control cuentan con puerto de comunicación RS485 para la comunicación remota con el grupo generador.



Los módulos pueden ser monitoreados através de un excelente software para observar parámetros del equipo de manera fácil y rápida.

La familia de módulos de control para la sincronía (6100, 6050 y 6300), incorporan un amplio sistema de monitoreos además de conexión a Internet (LAN) o mensaje SMS vía celular, o usando los puertos de comunicación RS485 a través de ModBus



ottomotors

Energía que Mueve al Mundo

Calz. San Lorenzo No.1150
Col. Cerro de la Estrella, C.P.09860
Delegación Iztapalapa México D.F.
Tels: 52-55-5624-5600
Fax: 52-55-5426-55-21 / 52-55-54265581

E-mail ventas1@ottomotors.com.mx
ventas2@ottomotors.com.mx

Web site. www.ottomotors.com.mx

MODELS
 CNE400
 CNY350
 CNY400

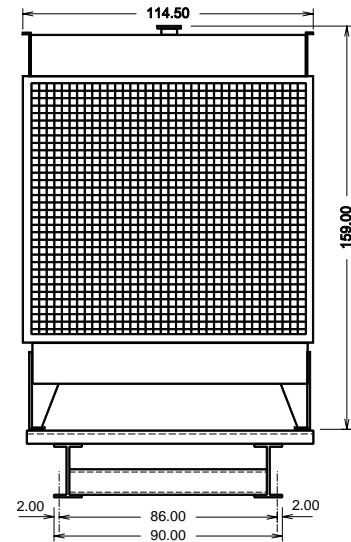
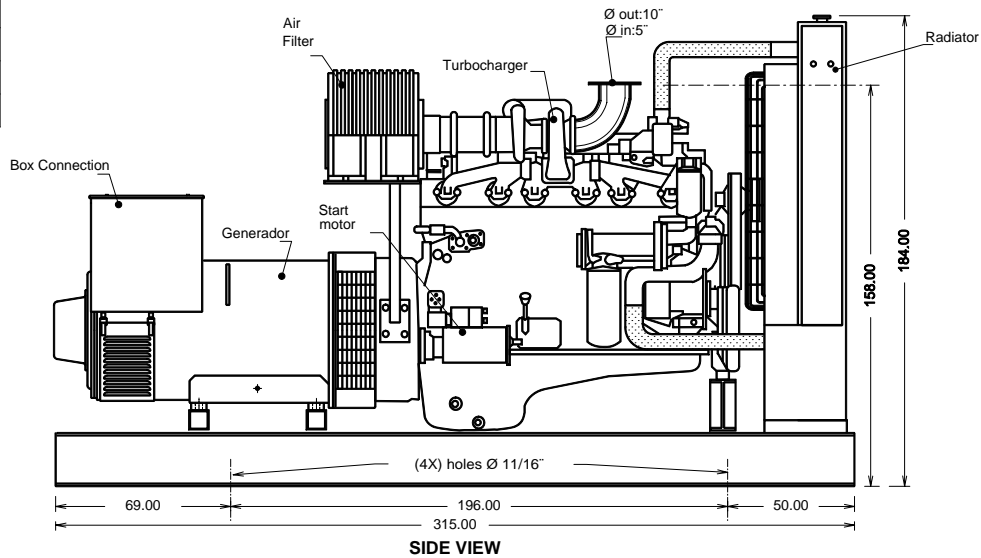

DESCRIPTION	
RADIATOR:	OV-12-6H
ENGINE:	NTA855G3/G4/G5
AIR: FILTER	AH1135
BASE FRAME:	BP-NTAG3-STF BP-NTAG5-STF
# SPRING AVMS:	4 PZS

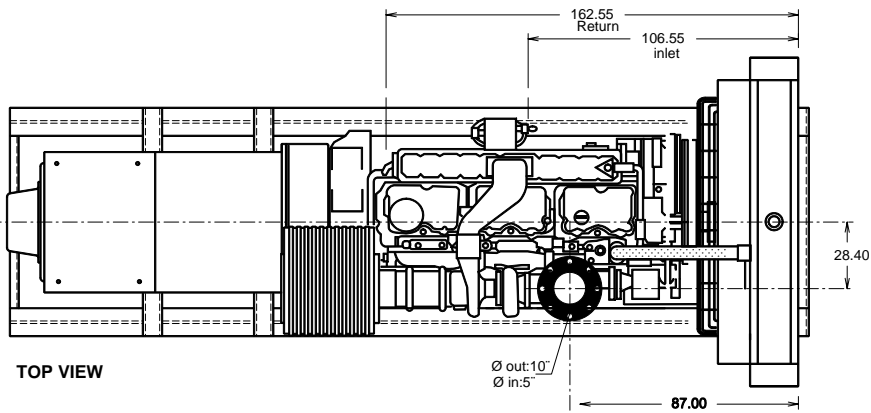

-THE GENSET DIMENSIONS ARE THE SAME BY FAMILY MODEL, THERE COULD BE ONLY DIFFERENCES ON THE ALTERNATOR LENGTH SEE SPECIFIC GENERAL ARRANGEMENT DRAWING OF CERTAIN MODEL
 -TOTAL WEIGHT COULD VARY CHECK RATING CHART FOR EACH MODEL

Customer: _____ S/O: _____

Rev.	Description	Date	Certificated

Title: **CUMMINS ENGINE NTA855G3/G4/G5 - STAMFORD ALTERNATOR**

Draw: R.G.C. Revised: F.H.M. Certificated: F.H.M. Code: **CNEY-10**

Date: JAN 05th 2005 Date: JAN 05th 2005 Date: JAN 05th 2005 Dept.: Engineering

Marks: cms Draw:
 Scale: s/e Of:
 Ⓢ

Reviews

Otomotors keeps the right to change the information with out prior notice

**CUMMINS ENGINE COMPANY, INC**

Columbus, Indiana 47201

ENGINE PERFORMANCE CURVEBasic Engine Model:
NTA855-G3Curve Number:
FR-1623Page
No.Engine Critical Parts List:
CPL: 0991Date:
30Sep98Displacement : **14.0 litre (855 in³)**Bore : **140 mm (5.5 in.)** Stroke : **152 mm (6.0 in.)**No. of Cylinders : **6**Aspiration : **Turbocharged and Aftercooled**

Engine Speed RPM	Standby Power		Prime Power		Continuous Power	
	kWm	BHP	kWm	BHP	kWm	BHP
1500	----	----	----	----	----	----
1800	399	535	358	480	280	375

Engine Performance Data @ 1500 RPM**Not Available at 1500 RPM****Not Available at 1500 RPM****Engine Performance Data @ 1800 RPM**

OUTPUT POWER			FUEL CONSUMPTION			
%	kWm	BHP	kg/ kWm-h	lb/ BHP-h	litre/ hour	U.S. Gal/ hour
STANDBY POWER						
100	399	535	0.205	0.336	96	25.3
PRIME POWER						
100	358	480	0.207	0.339	87	22.9
75	269	360	0.209	0.345	66	17.5
50	179	240	0.223	0.384	47	12.3
25	90	120	0.255	0.420	27	7.1
CONTINUOUS POWER						
100	280	375	0.208	0.344	69	18.2

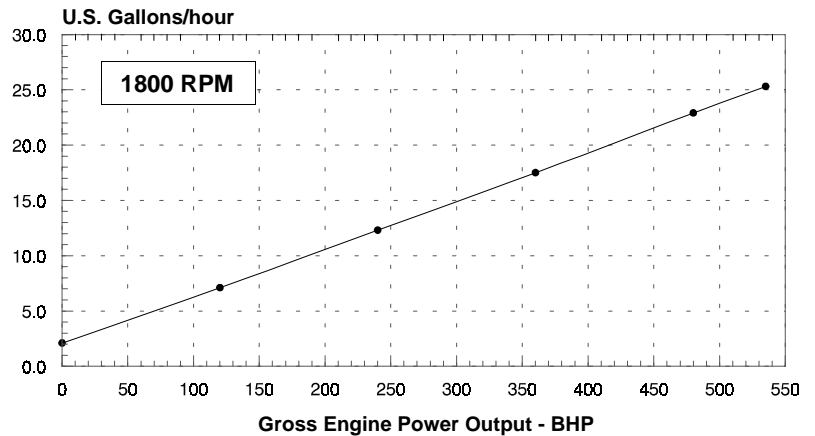

CONVERSIONS: (Litres = U.S. Gal x 3.785) (Engine kWm = BHP x 0.746) (U.S. Gal = Litres x 0.2642) (Engine BHP = Engine kWm x 1.34)

Data shown above represent gross engine performance capabilities obtained and corrected in accordance with ISO-3046 conditions of 100 kPa (29.53 in Hg) barometric pressure [110 m (361 ft) altitude], 25 °C (77 °F) air inlet temperature, and relative humidity of 30% with No. 2 diesel or a fuel corresponding to ASTM D2. See reverse side for application rating guidelines.

The fuel consumption data is based on No. 2 diesel fuel weight at 0.85 kg/litre (7.1 lbs/U.S. gal).

Power output curves are based on the engine operating with fuel system, water pump and lubricating oil pump; not included are battery charging alternator, fan, optional equipment and driven components.

POWER RATING APPLICATION GUIDELINES FOR GENERATOR DRIVE ENGINES

These guidelines have been formulated to ensure proper application of generator drive engines in A.C. generator set installations. Generator drive engines are not designed for and shall not be used in variable speed D.C. generator set applications.

STANDBY POWER RATING is applicable for supplying emergency power for the duration of the utility power outage. No overload capability is available for this rating. Under no condition is an engine allowed to operate in parallel with the public utility at the Standby Power rating.

This rating should be applied where reliable utility power is available. A standby rated engine should be sized for a maximum of an 80% average load factor and 200 hours of operation per year. This includes less than 25 hours per year at the Standby Power rating. Standby ratings should never be applied except in true emergency power outages. Negotiated power outages contracted with a utility company are not considered an emergency.

CONTINUOUS POWER RATING is applicable for supplying utility power at a constant 100% load for an unlimited number of hours per year. No overload capability is available for this rating.

PRIME POWER RATING is applicable for supplying electric power in lieu of commercially purchased power. Prime Power applications must be in the form of one of the following two categories:

UNLIMITED TIME RUNNING PRIME POWER

Prime Power is available for an unlimited number of hours per year in a variable load application. Variable load should not exceed a 70% average of the Prime Power rating during any operating period of 250 hours.

The total operating time at 100% Prime Power shall not exceed 500 hours per year.

A 10% overload capability is available for a period of 1 hour within a 12 hour period of operation. Total operating time at the 10% overload power shall not exceed 25 hours per year.

LIMITED TIME RUNNING PRIME POWER

Prime Power is available for a limited number of hours in a non-variable load application. It is intended for use in situations where power outages are contracted, such as in utility power curtailment. Engines may be operated in parallel to the public utility up to 750 hours per year at power levels never to exceed the Prime Power rating. The customer should be aware, however, that the life of any engine will be reduced by this constant high load operation. Any operation exceeding 750 hours per year at the Prime Power rating should use the Continuous Power rating.

Reference Standards:

BS-5514 and DIN-6271 standards are based on ISO-3046.

Operation At Elevated Temperature And Altitude:

The engine may be operated at:

1800 RPM up to 5,000 ft. (1525 m) and 104 °F (40 °C) without power deration.

For sustained operation above these conditions, derate by 4% per 1,000 ft (300 m), and 1% per 10 °F (2% per 11 °C).

Cummins Engine Company, Inc.

Engine Data Sheet

ENGINE MODEL : **NTA855-G3**

CONFIGURATION NUMBER : D093580DX02

DATA SHEET : DS-4495-A

DATE : 30Sep98

PERFORMANCE CURVE : FR-1623

INSTALLATION DIAGRAM

• Fan to Flywheel : 3626385

CPL NUMBER

• Engine Critical Parts List

: 0991

GENERAL ENGINE DATA

Type	4-Cycle; In-line; 6-Cylinder Diesel
Aspiration	Turbocharged and Aftercooled
Bore x Stroke..... — in x in (mm x mm)	5.5 x 6.0 (140 x 152)
Displacement..... — in ³ (liter)	855 (14.0)
Compression Ratio.....	14.0 : 1
Dry Weight	
Fan to Flywheel Engine..... — lb (kg)	2900 (1315)
Heat Exchanger Cooled Engine..... — lb (kg)	3130 (1420)
Wet Weight	
Fan to Flywheel Engine..... — lb (kg)	3018 (1369)
Heat Exchanger Cooled Engine..... — lb (kg)	3308 (1501)
Moment of Inertia of Rotating Components	
• with FW 1109 Flywheel..... — lb _m • ft ² (kg • m ²)	118.5 (4.99)
• with FW 1001 Flywheel..... — lb _m • ft ² (kg • m ²)	180.3 (7.60)
Center of Gravity from Rear Face of Flywheel Housing..... — in (mm)	27.7 (704)
Center of Gravity Above Crankshaft Centerline..... — in (mm)	5.5 (140)
Maximum Static Loading at Rear Main Bearing..... — lb (kg)	N.A.

ENGINE MOUNTING

Maximum Bending Moment at Rear Face of Block..... — lb • ft (N • m)	1000 (1356)
---	-------------

EXHAUST SYSTEM

Maximum Back Pressure..... — in Hg (mm Hg)	3 (76)
--	--------

AIR INDUCTION SYSTEM

Maximum Intake Air Restriction		
• with Dirty Filter Element..... — in H ₂ O (mm H ₂ O)	25	(635)
• with Normal Duty Air Cleaner and Clean Filter Element..... — in H ₂ O (mm H ₂ O)	10	(254)
• with Heavy Duty Air Cleaner and Clean Filter Element..... — in H ₂ O (mm H ₂ O)	15	(381)

COOLING SYSTEM

Coolant Capacity — Engine Only..... — US gal (liter)	5.5	(20.8)
— with HX 1134 Heat Exchanger..... — US gal (liter)	13.0	(49.2)
Maximum Coolant Friction Head External to Engine		
— 1800 rpm..... — psi (kPa)	7	(48)
— 1500 rpm..... — psi (kPa)	6	(41)
Maximum Static Head of Coolant Above Engine Crank Centerline..... — ft (m)	60	(18.3)
Standard Thermostat (Modulating) Range..... — °F (°C)	180 - 200	(82 - 93)
Minimum Pressure Cap..... — psi (kPa)	10	(69)
Maximum Top Tank Temperature for Standby / Prime Power..... — °F (°C)	220 / 212	(104 / 100)
Minimum Raw Water Flow @ 90°F to HX 1134 Heat Exchanger..... — US gpm (liter / min)	54	(204)
Maximum Raw Water Inlet Pressure at HX 1134 Heat Exchanger..... — psi (kPa)	50	(345)

LUBRICATION SYSTEM

Oil Pressure @ Idle Speed..... — psi (kPa)	15	(103)
@ Governed Speed..... — psi (kPa)	35 - 45	(241 - 310)
Maximum Oil Temperature..... — °F (°C)	250	(121)
Oil Capacity with OP 1396 Oil Pan : High - Low..... — US gal (liter)	9.5 - 7.5	(36.0 - 28.4)
Total System Capacity (Including Combo Filter)..... — US gal (liter)	10.2	(38.6)
Angularity of OP 1396 Oil Pan — Front Down.....	45°	
— Front Up.....	45°	
— Side to Side.....	45°	

FRAME HC434F/444F HCK434F/444F

WINDING 311

RATINGS	REFER TO RATINGS BOOK
OVERLOAD	REFER TO RATINGS BOOK
ALTITUDE	REFER TO RATINGS BOOK
AMBIENT TEMP.	REFER TO RATINGS BOOK

CONTROL SYSTEM SER. 3	SEPARATELY EXCITED BY P.M.G. FRAME DESIGNATION HC434		
A.V.R.	MX341	MX321	
VOLTAGE REGULATION	± 1.0%	± 0.5%	WITH 4% ENGINE GOVERNING
SUSTAINED SHORT CIRCUIT	REFER TO SHORT CIRCUIT DECREMENT CURVES OF THIS SECTION		

CONTROL SYSTEM SER. 4	SELF EXCITED FRAME DESIGNATION HC444		
A.V.R.	SX440	SX421	
VOLTAGE REGULATION	± 1.0%	± 0.5%	WITH 4% ENGINE GOVERNING
SUSTAINED SHORT CIRCUIT	SERIES 4 CONTROL DOES NOT SUSTAIN A SHORT CIRCUIT CURRENT		

INSULATION SYSTEM	CLASS H	
PROTECTION	IP22 STANDARD - IP23 OPTIONAL (5% DERATE)	
RATED POWER FACTOR	0.8	
STATOR WINDING	DOUBLE LAYER LAP	
WINDING PITCH	TWO THIRDS	
WINDING LEADS	12	
STATOR WDG. RESISTANCE	0.010 Ohms PER PHASE AT 22°C SERIES STAR CONNECTED	
ROTOR WDG. RESISTANCE	1.35 Ohms at 22°C	
R.F.I. SUPPRESSION	BS EN 50081/2-1/2 VDE 0875G VDE 0875N For other standards apply to the factory	
WAVEFORM DISTORTION	NO LOAD < 1.5% NON-DISTORTING BALANCED LINEAR LOAD < 5.0%	
MAXIMUM OVERSPEED	2250 Rev/Min	
BEARING DRIVE END HC ONLY	BALL. 6317 (ISO)	
BEARING NON-DRIVE END	BALL. 6314 (ISO)	
EFFICIENCY	REFER TO EFFICIENCY CURVES OF THIS SECTION	
	1 BEARING	2 BEARING HC ONLY
WEIGHT COMP. GENERATOR	1170 kg	1160 kg
WEIGHT WOUND STATOR	535 kg	535 kg
WEIGHT WOUND ROTOR	473 kg	440 kg
WR ² INERTIA	5.53 kgm ²	5.22 kgm ²

	50 Hz				60 Hz			
TELEPHONE INTERFERENCE	THF < 2%				TIF < 50			
COOLING AIR FOR HC	0.486 m ³ /sec 1030 cfm				0.58 m ³ /sec 1240 cfm			
COOLING AIR FOR HCK	0.68 m ³ /sec 1450 cfm				0.83 m ³ /sec 1760 cfm			
VOLTAGE SERIES STAR (Y)	380/220	400/231	415/240	440/254	416/240	440/254	460/266	480/277
VOLTAGE PARALLEL STAR (Y)	190/110	200/115	208/120	220/127	208/120	220/127	230/133	240/138
VOLTAGE EDISON DELTA (Δ)	220/110	230/115	240/120	250/125	240/120	254/127	266/133	277/138
kVA BASE RATING FOR REACTANCE VALUES	380	380	380	380	444	456	463	475
X _d DIR. AXIS SYNCHRONOUS	2.59	2.34	2.17	1.93	3.21	2.95	2.74	2.59
X' _d DIR. AXIS TRANSIENT	0.17	0.16	0.14	0.13	0.18	0.18	0.17	0.16
X'' _d DIR. AXIS SUBTRANSIENT	0.12	0.11	0.10	0.09	0.13	0.12	0.12	0.11
X _q QUAD. AXIS REACTANCE	2.25	2.03	1.87	1.67	2.84	2.60	2.42	2.28
X'' _q QUAD. AXIS SUBTRANSIENT	0.31	0.28	0.25	0.23	0.42	0.38	0.36	0.34
X _L LEAKAGE REACTANCE	0.06	0.05	0.05	0.04	0.07	0.06	0.06	0.06
X ₂ NEGATIVE SEQUENCE	0.22	0.20	0.18	0.17	0.28	0.26	0.24	0.23
X ₀ ZERO SEQUENCE	0.09	0.07	0.07	0.06	0.10	0.08	0.08	0.08
REACTANCES ARE SATURATED				VALUES ARE PER UNIT AT RATING AND VOLTAGE INDICATED				
T' _d TRANSIENT TIME CONST.	0.080 sec							
T'' _d SUB-TRANSTIME CONST.	0.019 sec							
T' _{do} O.C. FIELD TIME CONST.	1.700 sec							
T _a ARMATURE TIME CONST.	0.018 sec							
SHORT CIRCUIT RATIO	1/X _d							

ISSUE 8

Continuous development of our products entitles us to change specification details without notice, therefore they must not be regarded as binding.

**SERIES 3 WINDING 311
 LOCKED ROTOR MOTOR STARTING CURVE**

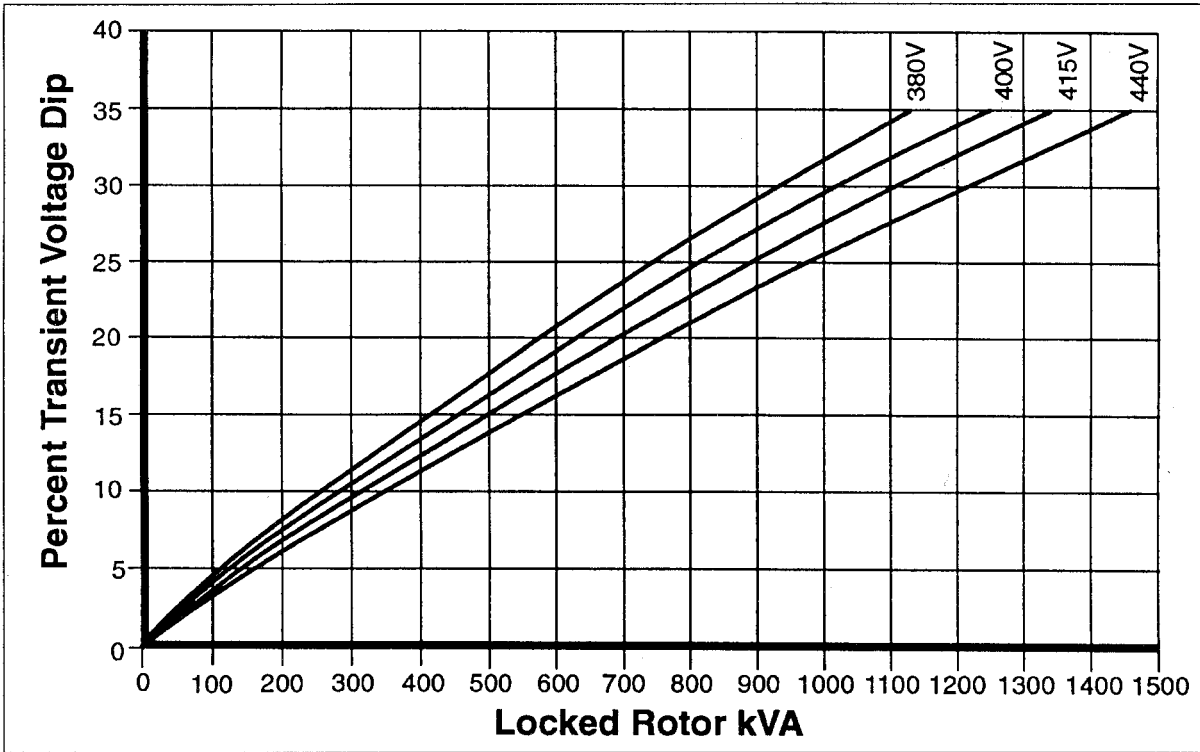

**SERIES 3 WINDING 311
 LOCKED ROTOR MOTOR STARTING CURVE**

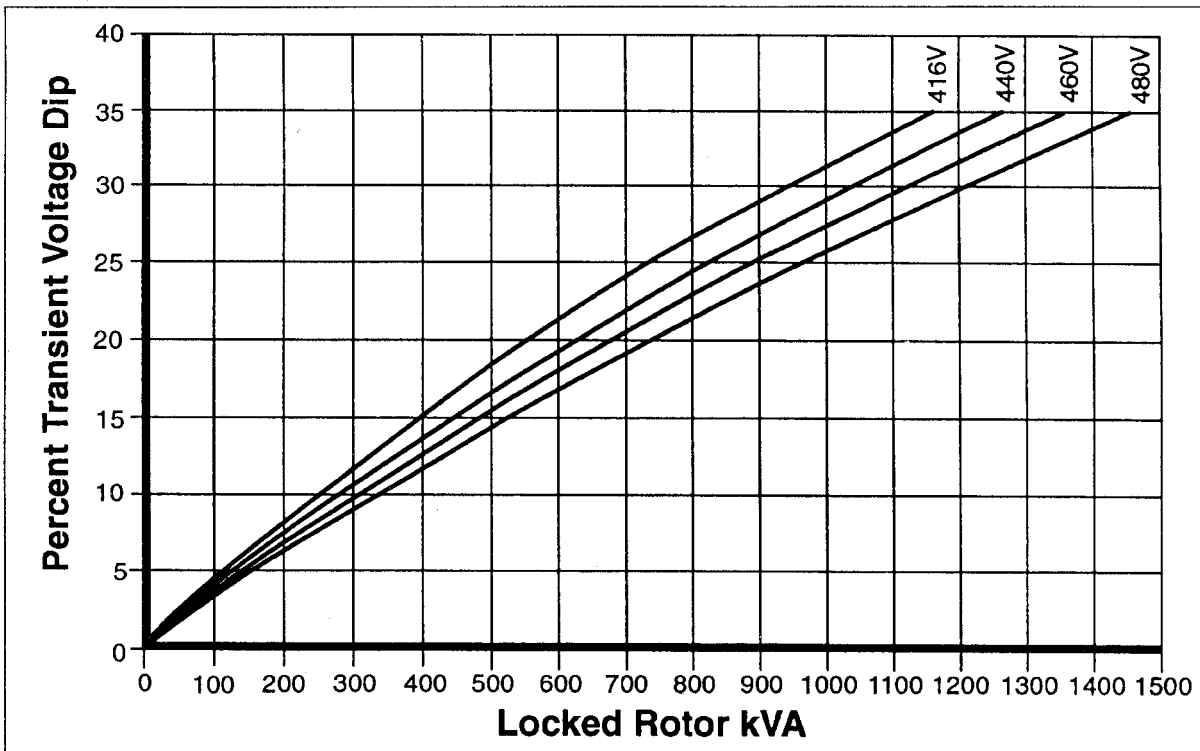

**SERIES 4 WINDING 311
LOCKED ROTOR MOTOR STARTING CURVE**

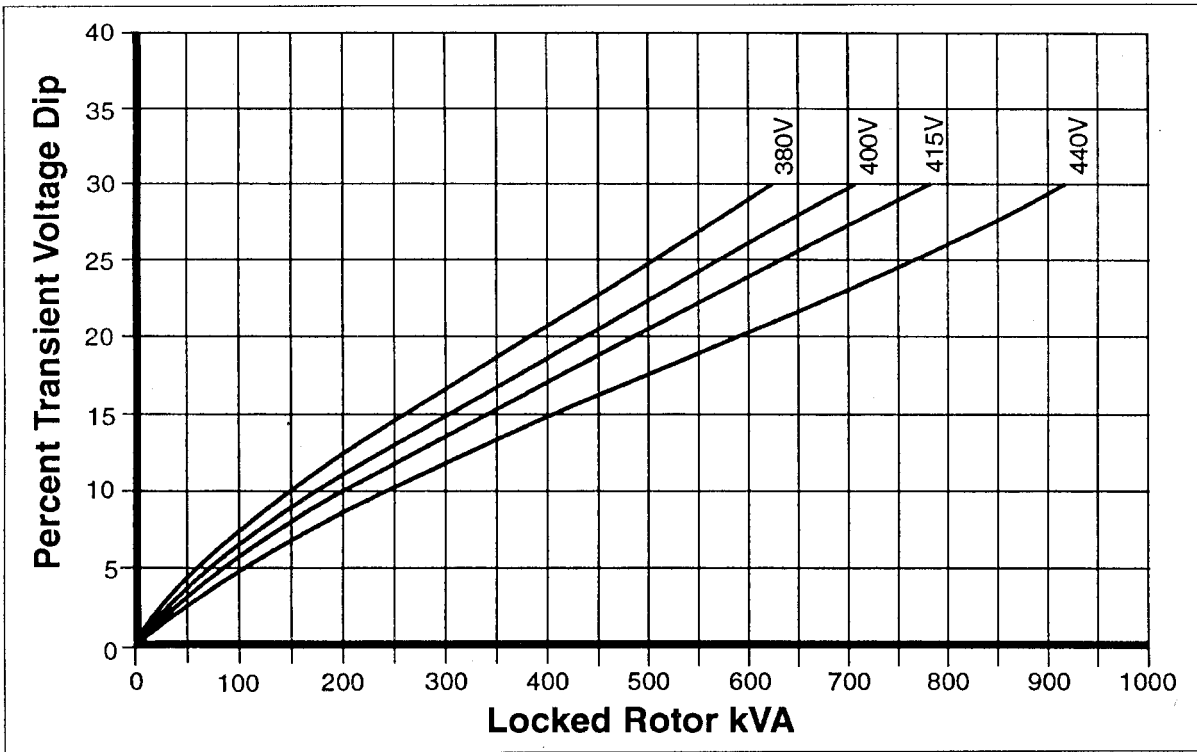

**SERIES 4 WINDING 311
LOCKED ROTOR MOTOR STARTING CURVE**

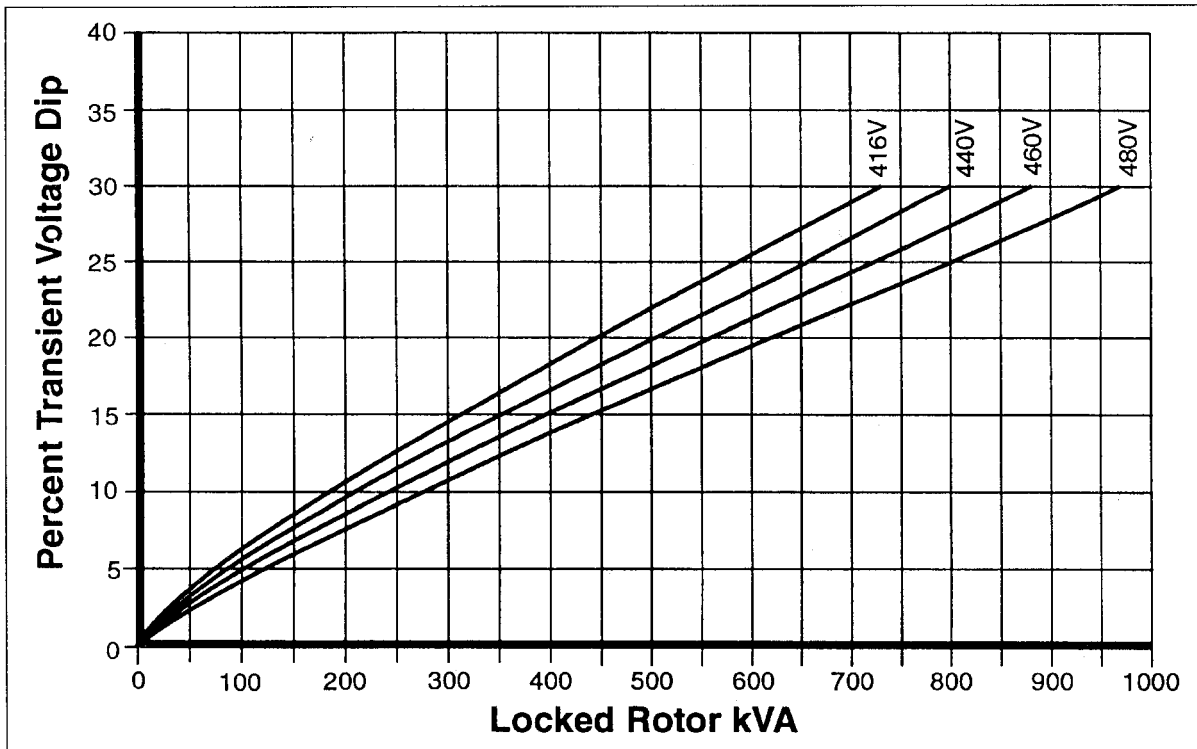

THREE PHASE EFFICIENCY CURVES

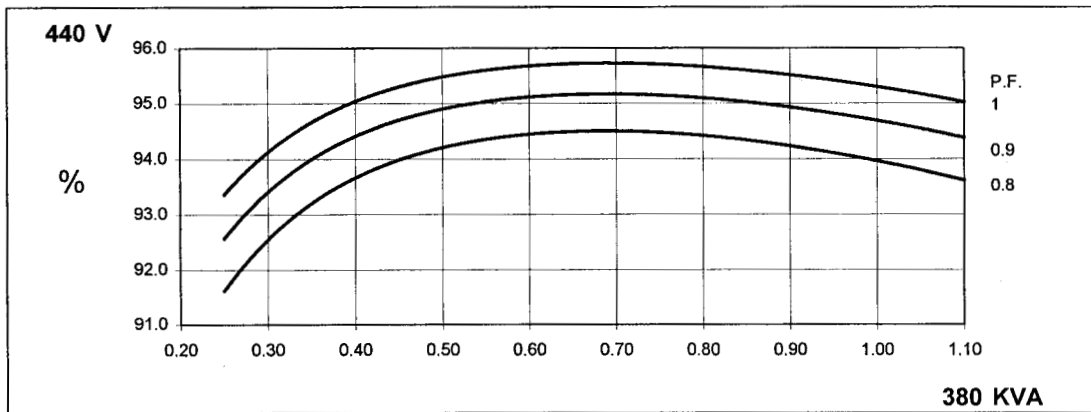
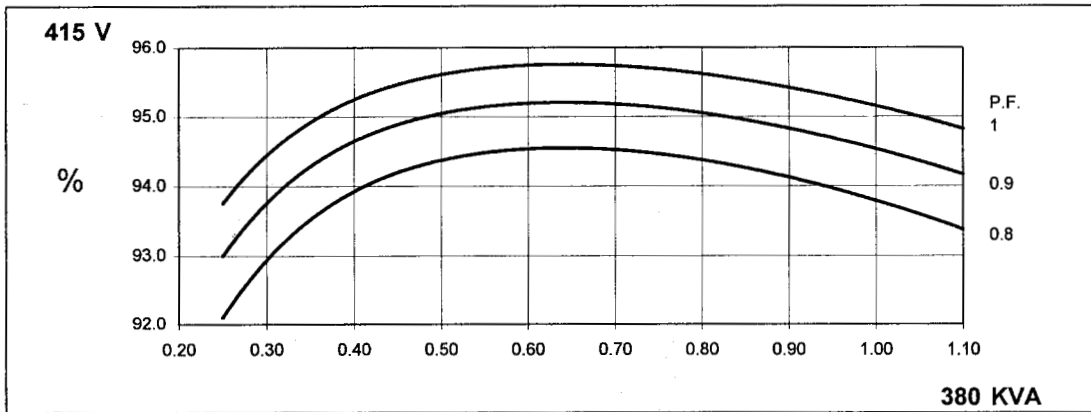
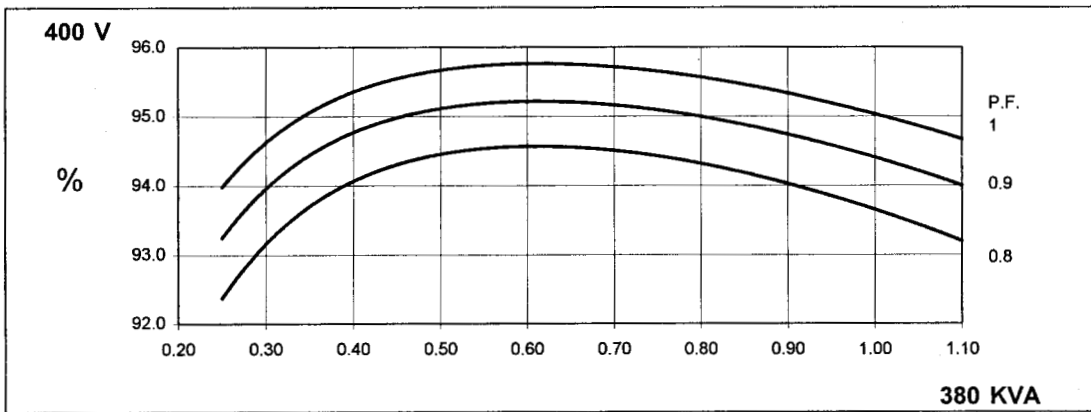
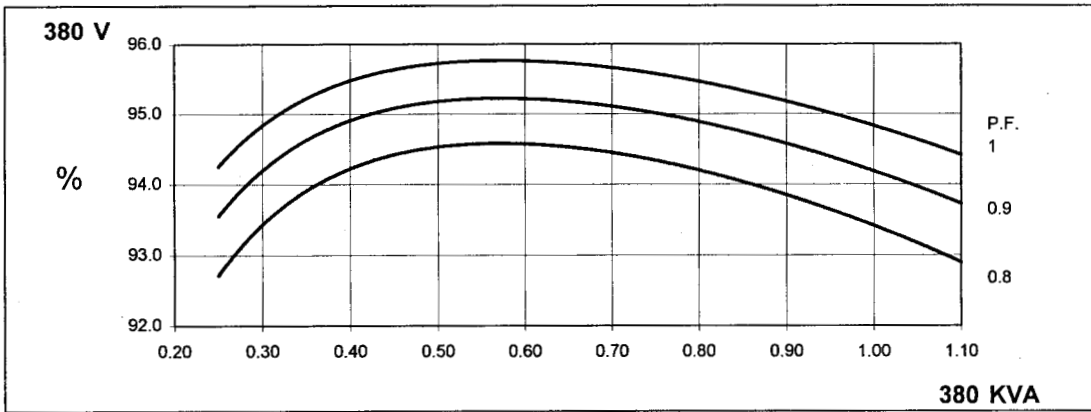

THREE PHASE EFFICIENCY CURVES

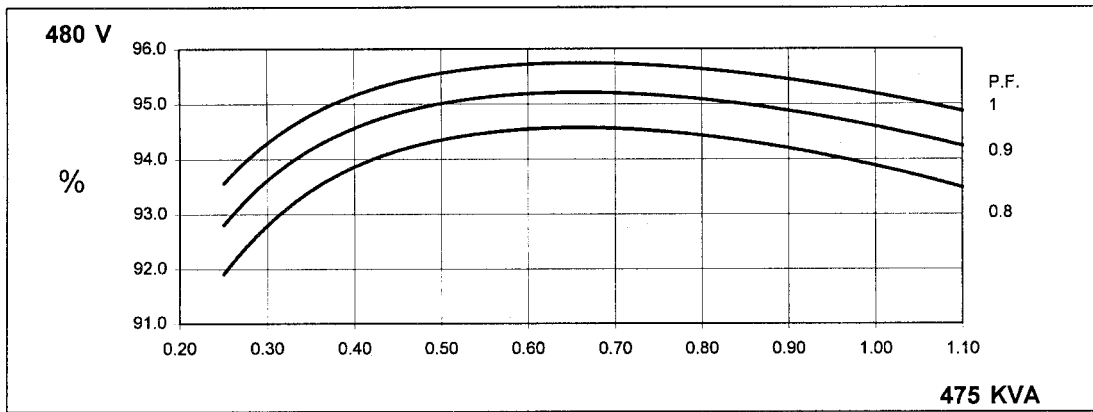
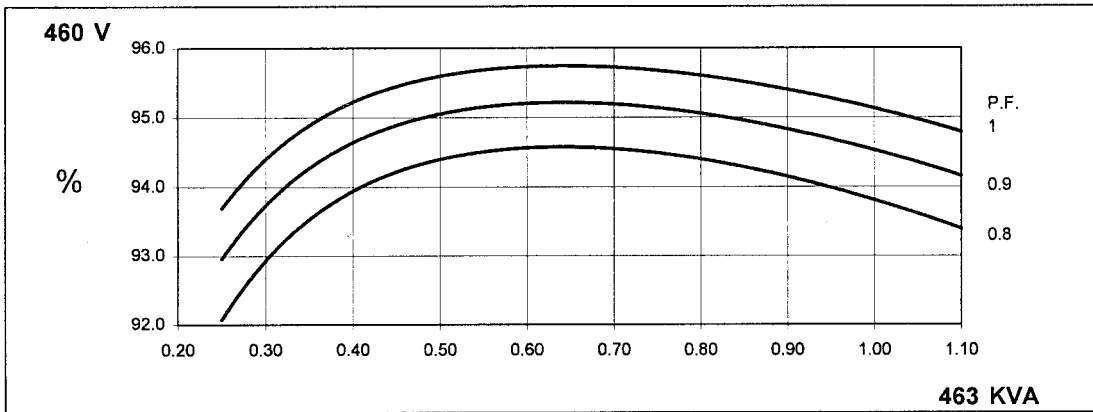
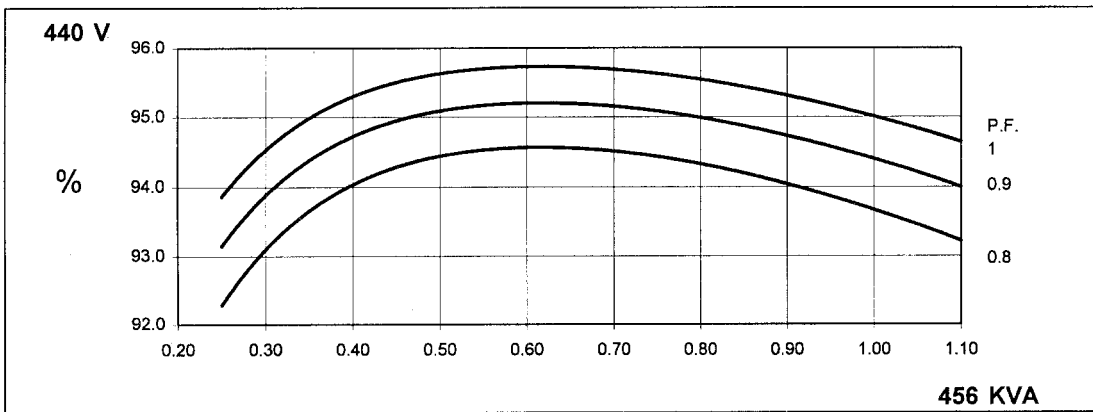
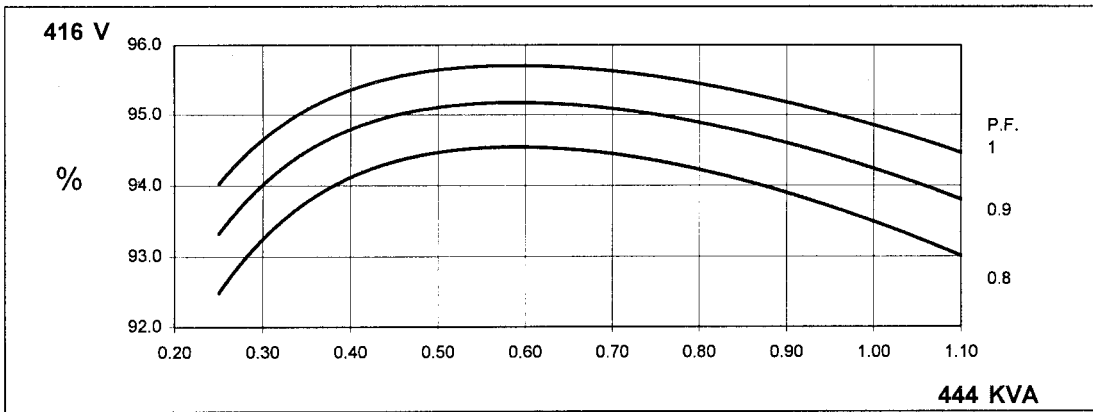

FRAME HC434F HCK434F 50 Hz

SERIES THREE

Three Phase Short Circuit Decrement Curve No-load Excitation at Rated Speed

Based on series star (wye) connection

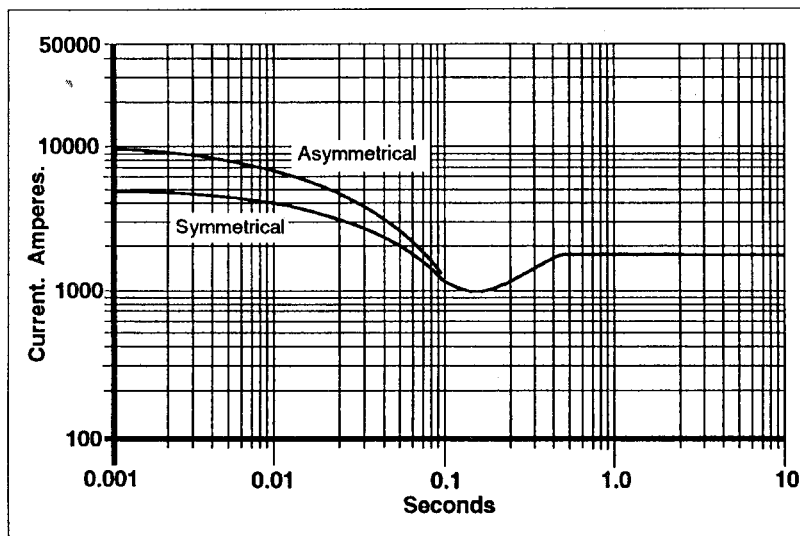

Note 1

The following multiplication factors should be used to adjust the values from curve between time 0.001 seconds and the minimum current point in respect of nominal operating voltage :

VOLTAGE	FACTOR
380 V	X 1.0
400 V	X 1.07
415 V	X 1.12
440 V	X 1.18

The sustained current value is constant irrespective of voltage level.

Note 2

The following multiplication factors should be used to convert the values calculated in accordance with NOTE 1 to those applicable to the various types of short circuit :

	3 PHASE	2 PHASE L-L	1 PHASE L-N
Instantaneous	X 1.00	X 0.87	X 1.30
Minimum	X 1.00	X 1.80	X 3.20
Sustained	X 1.00	X 1.50	X 2.50
Max. sustained duration	10 sec.	5 sec.	2 sec.

All other times are unchanged.

Note 3

Curves are drawn for Series Star (Wye) connected machines. For other connections the following multipliers should be applied to current values shown :

Parallel Star (Wye) Curve current value X 2
Series Delta (Δ) Curve current value X 1.732

Times are unchanged.

FRAME HC434F HCK434F 60 Hz

SERIES THREE

Three Phase Short Circuit Decrement Curve No-load Excitation at Rated Speed

Based on series star (wye) connection

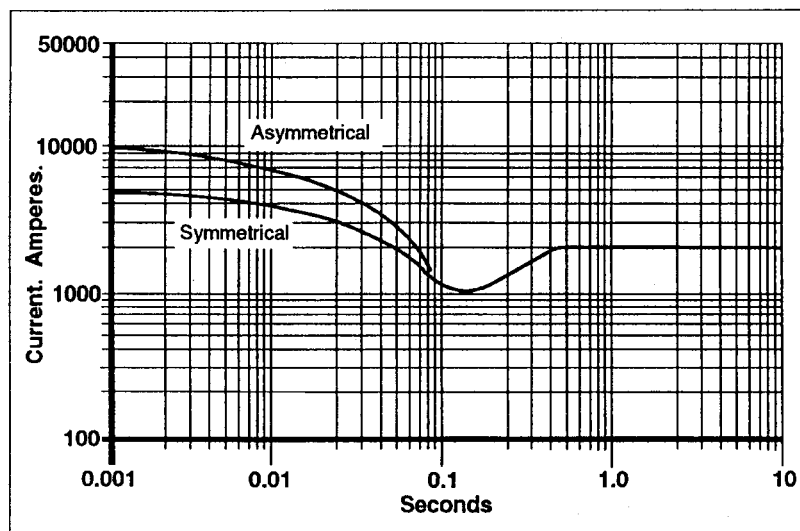

Note 1

The following multiplication factors should be used to adjust the values from curve between time 0.001 seconds and the minimum current point in respect of nominal operating voltage :

VOLTAGE	FACTOR
416 V	X 1.0
440 V	X 1.05
460 V	X 1.08
480 V	X 1.12

The sustained current value is constant irrespective of voltage level.

Note 2

The following multiplication factors should be used to convert the values calculated in accordance with NOTE 1 to those applicable to the various types of short circuit :

	3 PHASE	2 PHASE L-L	1 PHASE L-N
Instantaneous	X 1.00	X 0.87	X 1.30
Minimum	X 1.00	X 1.8	X 3.20
Sustained	X 1.00	X 1.50	X 2.50
Max. sustained duration	10 sec.	5 sec.	2 sec.

All other times are unchanged.

Note 3

Curves are drawn for Series Star (Wye) connected machines. For other connections the following multipliers should be applied to current values shown :

Parallel Star (Wye) Curve current value X 2
Series Delta (Δ) Curve current value X 1.732

Times are unchanged.

NEWAGE
INTERNATIONAL

NEWAGE INTERNATIONAL LIMITED
PO Box 17, Barnack Road, Stamford, Lincolnshire PE9 2NB, England.
Telephone 44 (0) 1780 484000
Telex 32268 Cables Newage Stamford Fax 44 (0) 1780 484100