



ottomotores

CUMMINS SERIE 6C

Energía que Mueve al Mundo

Definiciones

Potencia Prime

Estos valores son aplicables para el suministro de energía eléctrica continua (a carga variable) en lugar de la red comercial + 10% sobrecarga

Potencia Stand by

Estos valores son aplicables para el suministro de energía eléctrica continua (con carga variable) en caso de falla de la red comercial. No se permite sobrecarga sobre estos valores.

Tabla de Potencias

Modelo	Voltaje	kVA Prime	kWe Prime	kVA Stand-by	kWe Stand-by
CNY150	220-440V	170	136	188	150
CNY175	220-440V	199	159	219	175
CNY200	220-440V	227	182	250	200

0.8 Factor de potencia

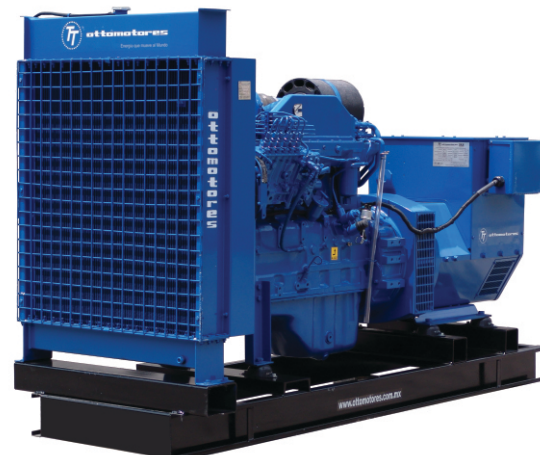

Información Técnica

Datos Técnicos	CNY150 / CNY175	CNY200
Frecuencia:	60 Hz	60 Hz
Marca / Modelo	6CTA8.3G2	6CTAA8.3G3
Generador Modelo:	Stamford UCI274F	Stamford UCI274H
Número de Cilindros:	6 en línea	6 en línea
Diametro por Carrera .in (mm)	4.49X5.32 (114X135)	4.49X5.32 (114X135)
Relación de Compresión:	16.8 : 1	16.8 : 1
Aspiración:	Turbo y Postenfriado	Turbo y cambio c/aire
Velocidad:	1800 RPM	1800 RPM
Potencia: BHP(kWm)	277 (207)	317 (237)
Presion Efectiva: psi (kPA)	242 (1669)	276 (1905)
Velocidad dePiston: ft/min (m/s)	1596 (8.1)	1596 (8.1)
Consumo a plena carga: lt / hr - 100%	45	64
Calor Expulsado en el Sistema de Escape: BTU/min (kWm)	10220 (180)	13142 (231)
Calor Expulsado en el Sistema de Enfriamiento: BTU/min (kWm)	6630 (117)	2916 (51)
Temperatura de Escape: °F (°C)	1055 (569)	1056 (569)
Flujo de Enfriamiento en el Radiador m³/seg - FPM	llame a fabrica	llame a fabrica
Flujo de Escape: cfm	1515 (715)	1819 (858)

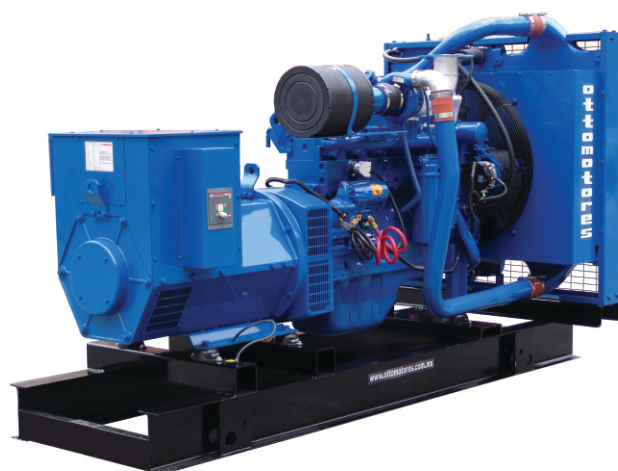

Nota: Imagen de carácter ilustrativa ya que los equipos en foto pudieran incluir accesorios opcionales

Como leer nuestro codigo: Ejem: CNY150

C=Motor Cummins
N=Generador Newage Stamford
Y=60Hz-1800 RPM
150= Potencia del Equipo.



LAPEM

Ottomotores, S.A de C.V.

Calz. San Lorenzo No.1150
Col. Cerro de la estrella, C.P. 09860
Delg. Iztapalapa México, D.F.
Tels:52-55-5624-5600

Fax: 52-55-5426-5521 / 52-55-5426-5581
email: ventas@ottomotores.com.mx

sitio web: www.ottomotores.com.mx

Dimensiones



Tabla de Dimensiones

CNY150	Equipo con Base Estructural			Equipo con Base Tanque			Equipo con Caseta Acústica*		
	A	B	C	x	y	z	D	E	F
	235,00	91,00	123,00	260,00	109,00	170,00	326,00	109,00	192,00
	Peso: 1357,00 kgs			Peso: 1780,00 kgs					

CNY175	Equipo con Base Estructural			Equipo con Base Tanque			Equipo con Caseta Acústica*		
	A	B	C	x	y	z	D	E	F
	235,00	91,00	149,00	260,00	109,00	170,00	326,00	109,00	192,00
	Peso: 1407,00 kgs			Peso: 1796,00 kgs					

CNY200	Equipo con Base Estructural			Equipo con Base Tanque			Equipo con Caseta Acústica*		
	A	B	C	x	y	z	D	E	F
	260,00	120,00	160,00	280,00	145,00	179,50	343,00	145,00	190,00
	Peso: 1642,00 kgs			Peso: 2035,00 kgs					

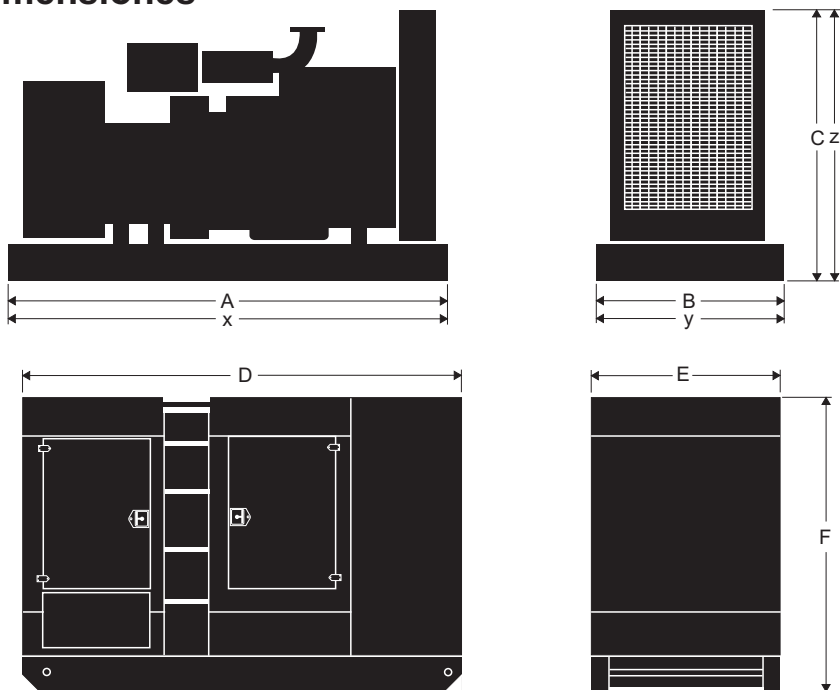
[*] Equipo opcional

Información Técnica

Nota: las condiciones de referencia estándar son de 25 °C (77 ° F) temperatura de entrada de aire. Todos los datos de desempeño de motores son basados en la potencia mencionada arriba.

Datos de consumo de combustible a plena carga con combustible diesel tienen una gravedad específica de 0,85.

Comercializado por:

Módulos de Control



Ottomotores tiene una posición única en la fabricación de grupos electrógenos utilizando en ellos módulos de control que cumplen con todos los niveles de requerimiento del mercado nacional y de exportación.



Las diferentes soluciones de controles que se tienen para nuestra gama de plantas generadoras, permite una operación simple en modo manual y automático, así mismo permiten desarrollar proyectos de sincronía entre plantas generadoras o con la red de energía eléctrica.



La familia de módulos de control en transición abierta (DALE 3200) permite tener control en forma automática de la unidad de transferencia, así como el monitoreo del grupo generador.



Nuestro módulos de control cuentan con puerto de comunicación RS485 para la comunicación remota con el grupo generador.



Los módulos pueden ser monitoreados a través de un excelente software para observar parámetros del equipo de manera fácil y rápida.



La familia de módulos de control para la sincronía (6100, 6050 y 6300), incorporan un amplio sistema de monitoreos además de conexión a Internet (LAN) o mensaje SMS vía celular, o usando los puertos de comunicación RS485 a través de ModBus



ottomotores

Energía que Mueve al Mundo

Calz. San Lorenzo No.1150
Col. Cerro de la Estrella, C.P.09860
Delegación Iztapalapa México D.F.
Tels: 52-55-5624-5600
Fax: 52-55-5426-55-21 / 52-55-54265581

E-mail ventas1@ottomotores.com.mx
ventas2@ottomotores.com.mx

Web site. www.ottomotores.com.mx

MODELS
 CNE175
 CNY190
 CNY150
 CNY175

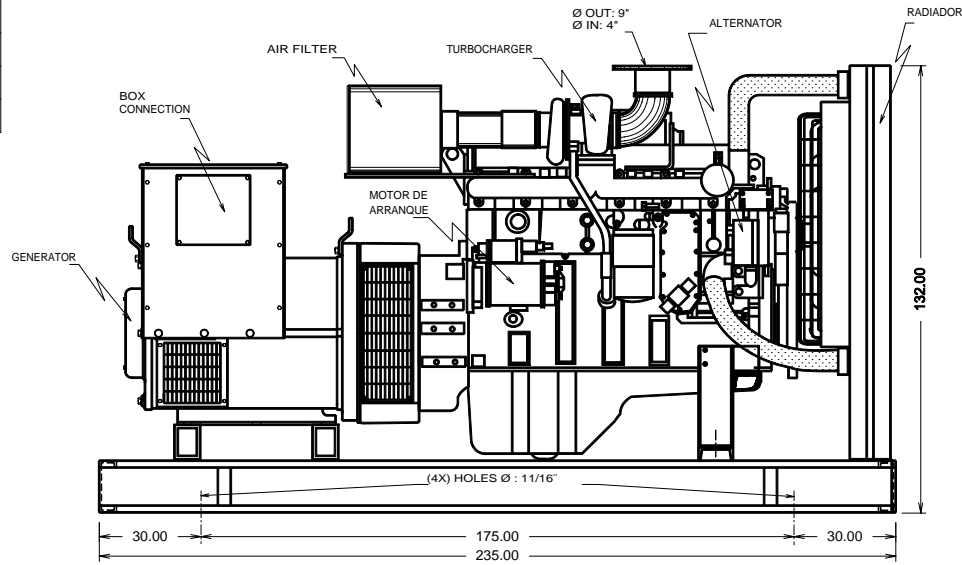

SIDE VIEW

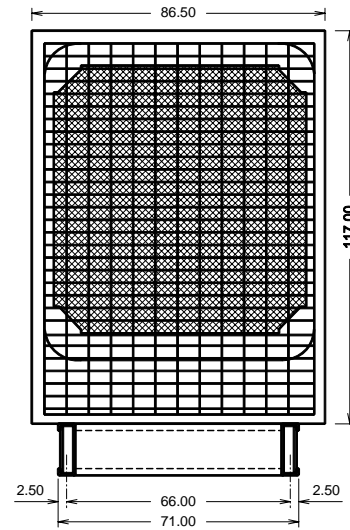

FRONT VIEW

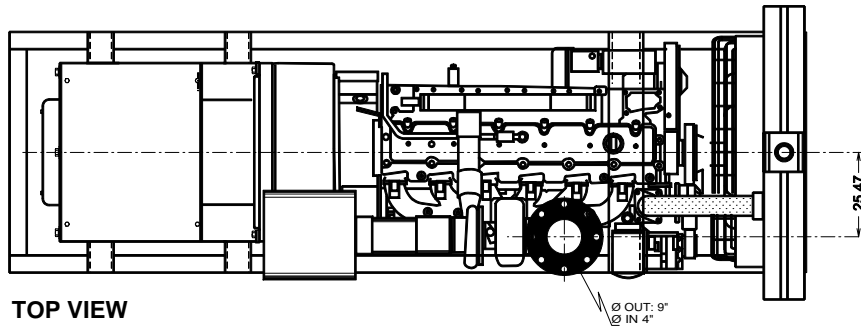

TOP VIEW

DESCRIPTION	
RADIATOR:	OT3 - 125
ENGINE:	6CTA8.3G2
AIR FILTER:	AH1196
BASE FRAME:	BMT-6CTA8-STF
# SPRING AVMS	4 PZS

NOTES:
 -THE GENSET DIMENSIONS ARE THE SAME BY FAMILY MODEL, THERE COULD BE ONLY DIFFERENCES ON THE ALTERNATOR LENGHT SEE SPECIFIC GENERAL ARRAGEMENT DRAWING OF CERTAIN MODEL
 -TOTAL WEIGHT COULD VARY CHECK RATING CHART FOR EACH MODEL

Customer:	S/O:	Title: CUMMINS ENGINE 6CTA8.3G2 - STAMFORD ALTERNATOR				
		Draw: R.G.C.	Revised: F.H.M.	Certificated: F.H.M.	Code: CNEY-06	
		Date: JAN 05th 2005	Date: JAN 05th 2005	Date: JAN 05th 2005	Dept.: Engineering	
					Marks: cms	Draw:
					Scale: s/e	Of:
Rev.	Description	Date	Certificated			
Reviews				Ottomotors keeps the right to change the information with out prior notice		

FRAME UC274G

WINDING 311

RATINGS	REFER TO RATINGS BOOK
OVERLOAD	REFER TO RATINGS BOOK
ALTITUDE	REFER TO RATINGS BOOK
AMBIENT TEMP.	REFER TO RATINGS BOOK

CONTROL SYSTEM SER. 3	SEPARATELY EXCITED BY P.M.G.		
A.V.R.	MX341	MX321	
VOLTAGE REGULATION	± 1.0 %	± 0.5%	WITH 4% ENGINE GOVERNING
SUSTAINED SHORT CIRCUIT	REFER TO SHORT CIRCUIT DECREMENT CURVES OF THIS SECTION		

CONTROL SYSTEM SER. 4	SELF EXCITED		
A.V.R.	SX460	SX440	SX421
VOLTAGE REGULATION	± 1.5%	± 1.0%	± 0.5%
SUSTAINED SHORT CIRCUIT	SERIES 4 CONTROL DOES NOT SUSTAIN A SHORT CIRCUIT CURRENT		

INSULATION SYSTEM	CLASS H	
PROTECTION	IP22 STANDARD - IP23 OPTIONAL (5% DERATE)	
RATED POWER FACTOR	0.8	
STATOR WINDING	DOUBLE LAYER CONCENTRIC	
WINDING PITCH	TWO THIRDS	
WINDING LEADS	12	
STATOR WDG. RESISTANCE	0.021 Ohms PER PHASE AT 22°C SERIES STAR CONNECTED	
ROTOR WDG. RESISTANCE	1.76 Ohms at 22°C	
R.F.I. SUPPRESSION	B.S. 800 VDE 0875G VDE 0875N For other standards apply to the factory	
WAVEFORM DISTORTION	NO LOAD < 1.8% NON-DISTORTING BALANCED LINEAR LOAD < 5.0%	
MAXIMUM OVERSPEED	2250 Rev/Min	
BEARING DRIVE END	BALL. 6315 - 2RS. (ISO)	
BEARING NON-DRIVE END	BALL. 6310 - 2RS. (ISO)	
EFFICIENCY	REFER TO EFFICIENCY CURVES OF THIS SECTION	
	1 BEARING	2 BEARING
WEIGHT COMP. GENERATOR	583 kg	600 kg
WEIGHT WOUND STATOR	225 kg	225 kg
WEIGHT WOUND ROTOR	213.04 kg	201.57 kg
WR ² INERTIA	1.824 kgm ²	1.7703 kgm ²

	50 Hz				60 Hz			
TELEPHONE INTERFERENCE	THF < 2%				TIF < 50			
COOLING AIR	0.514 m ³ /sec 1090 cfm				0.617 m ³ /sec 1308 cfm			
VOLTAGE SERIES STAR (Y)	380	400	415	440	416	440	460	480
VOLTAGE PARALLEL STAR (Y)	190	200	208	220	208	220	230	240
VOLTAGE EDISON DELTA (Δ)	220	230	240	250	240	254	266	277
kVA BASE RATING FOR REACTANCE VALUES	175	175	175	171	200	212	212	225
X _d DIR. AXIS SYNCHRONOUS	2.19	1.97	1.83	1.58	2.51	2.38	2.17	2.11
X' _d DIR. AXIS TRANSIENT	0.18	0.17	0.16	0.14	0.22	0.21	0.18	0.18
X'' _d DIR. AXIS SUBTRANSIENT	0.13	0.12	0.11	0.10	0.15	0.14	0.12	0.12
X _q QUAD. AXIS REACTANCE	1.31	1.18	1.10	0.95	1.52	1.45	1.31	1.28
X'' _q QUAD. AXIS SUBTRANSIENT	0.17	0.16	0.15	0.13	0.19	0.18	0.16	0.16
X _L LEAKAGE REACTANGLE	0.08	0.07	0.07	0.06	0.09	0.09	0.08	0.08
X ₂ NEGATIVE SEQUENCE	0.14	0.12	0.11	0.10	0.16	0.15	0.14	0.13
X ₀ ZERO SEQUENCE	0.09	0.08	0.07	0.06	0.10	0.09	0.08	0.08

REACTANCES ARE SATURATED

VALUES ARE PER UNIT AT RATING AND VOLTAGE INDICATED

T' _d TRANSIENT TIME CONST.	0.038 sec
T'' _d SUB-TRANSTIME CONST.	0.012 sec
T' _{do} O.C. FIELD TIME CONST.	1.000 sec
T _a ARMATURE TIME CONST.	0.010 sec
SHORT CIRCUIT RATIO	1/x _d

ISSUE 3

Continuous development of our products entitles us to change specification details without notice. Therefore they must not be regarded as binding.

**SERIES 3 WINDING 311
LOCKED ROTOR MOTOR STARTING CURVE**

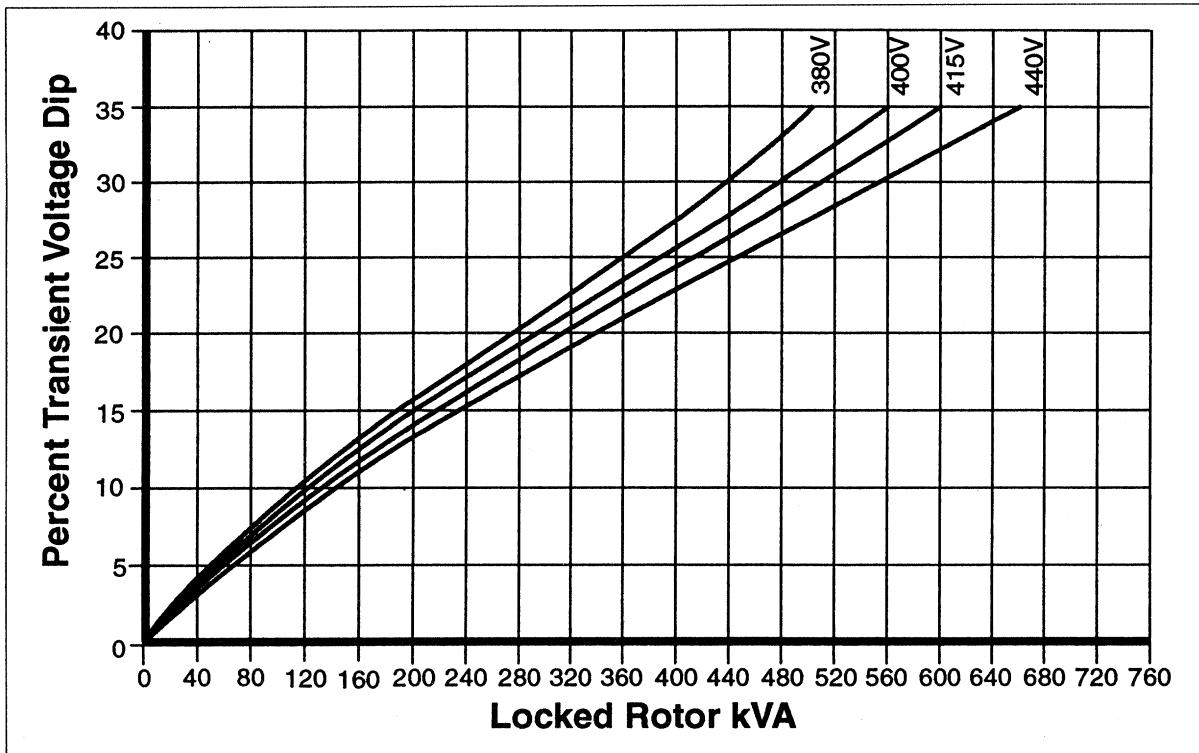

FRAME UC274G 60 HZ

**SERIES 3 WINDING 311
LOCKED ROTOR MOTOR STARTING CURVE**

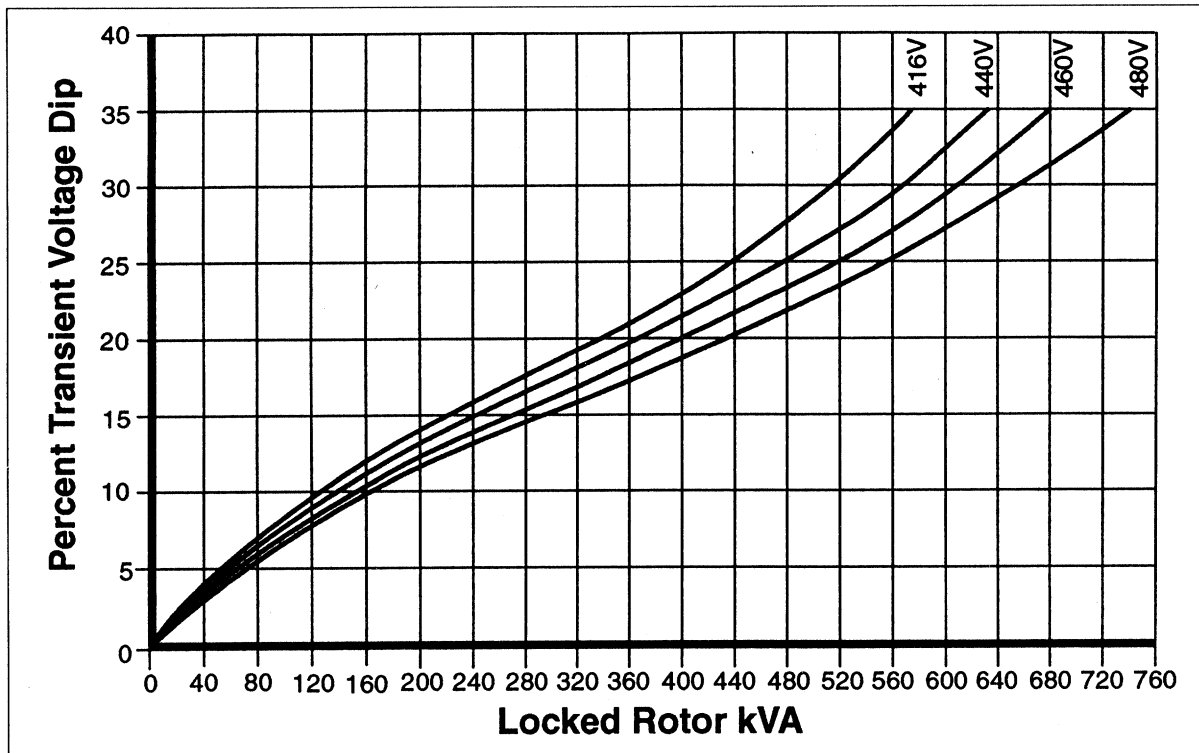

**SERIES 4 WINDING 311
LOCKED ROTOR MOTOR STARTING CURVE**

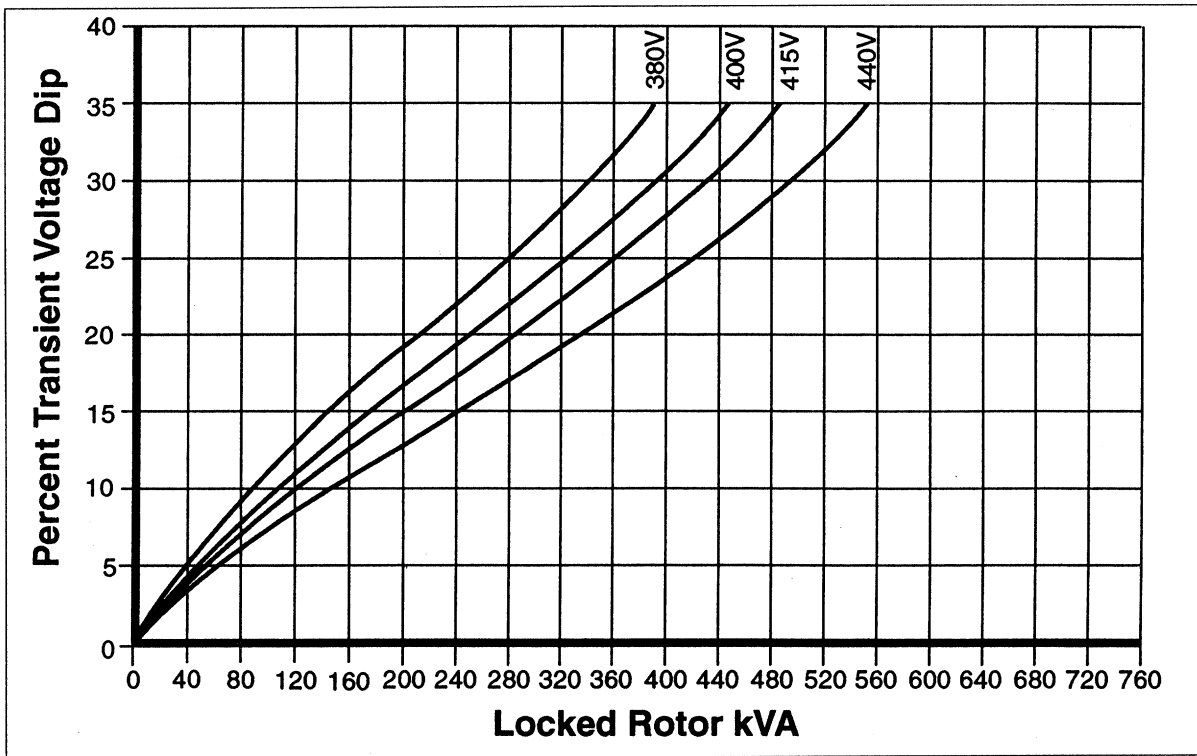

**SERIES 4 WINDING 311
LOCKED ROTOR MOTOR STARTING CURVE**

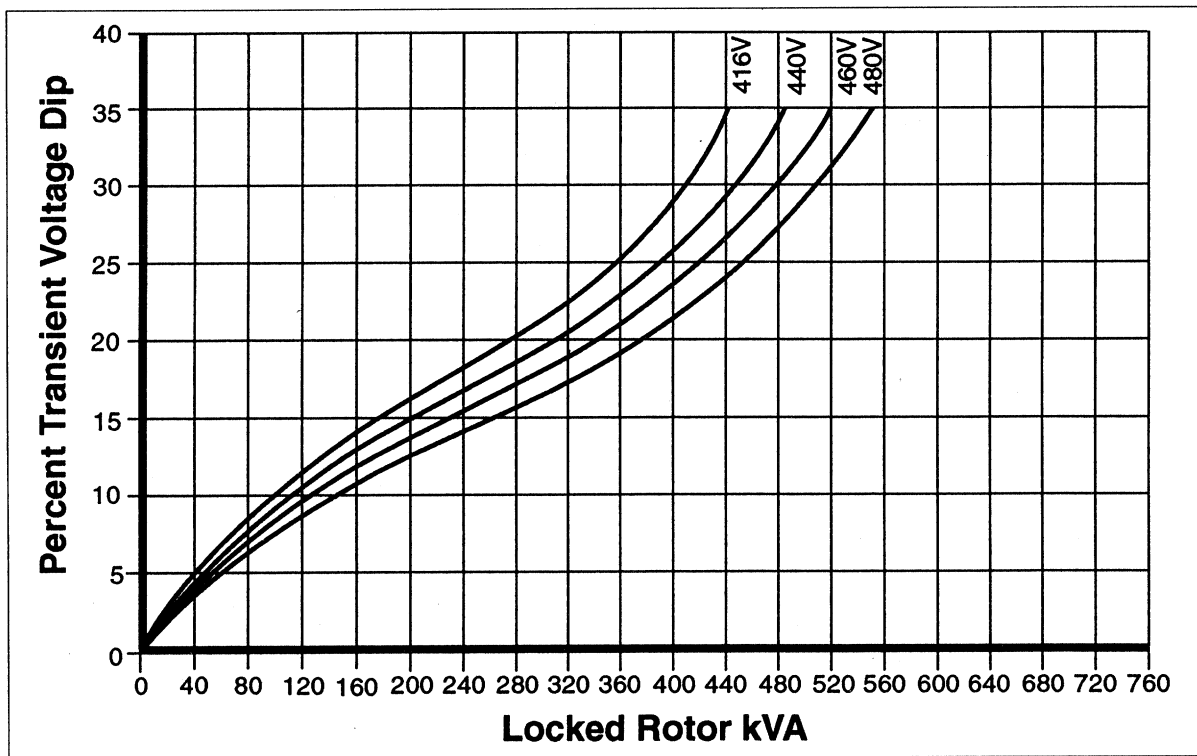

THREE PHASE EFFICIENCY CURVES

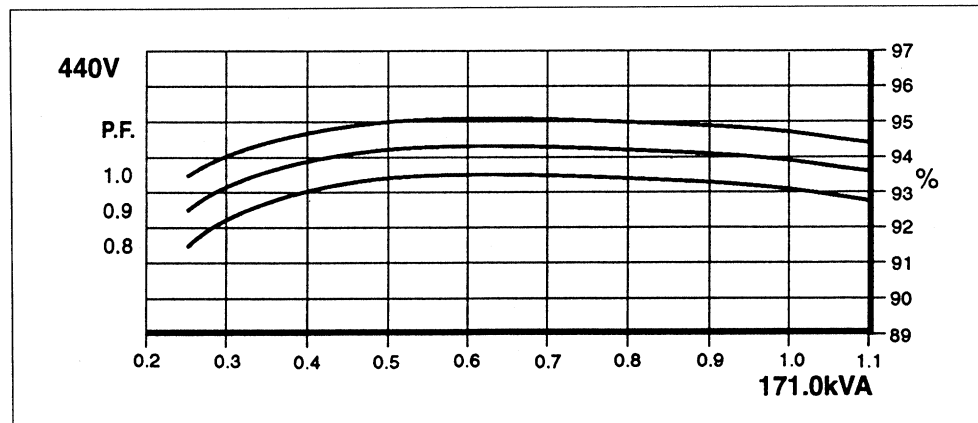
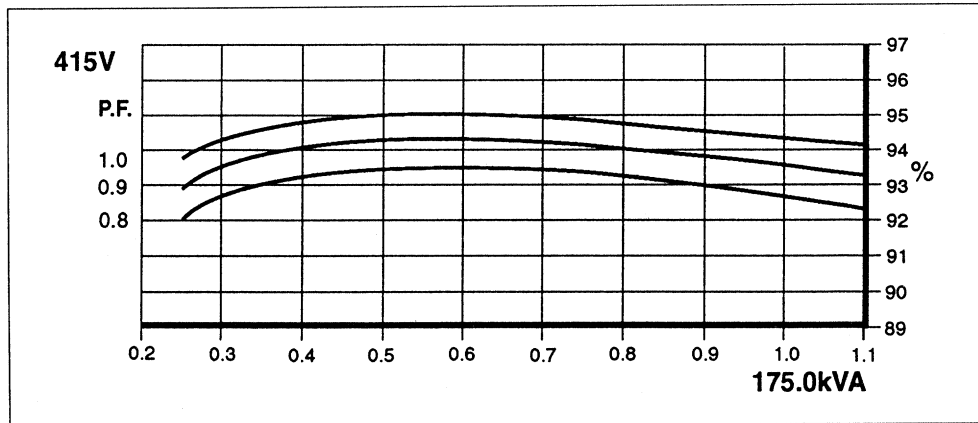
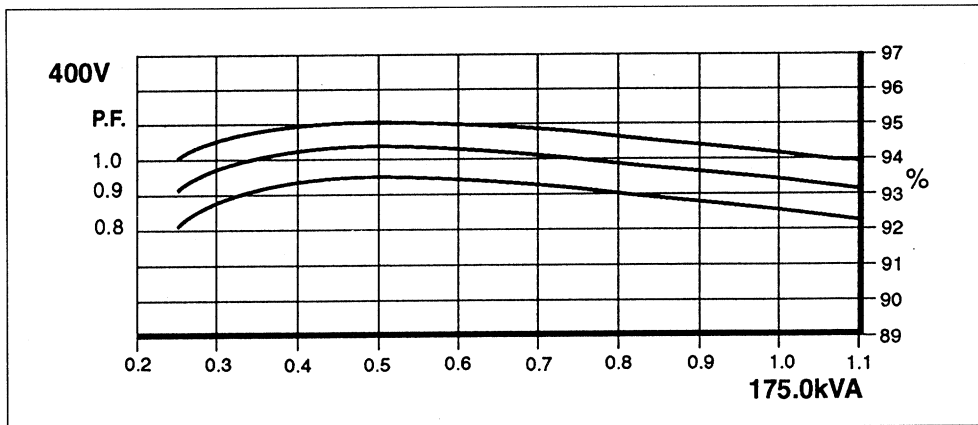
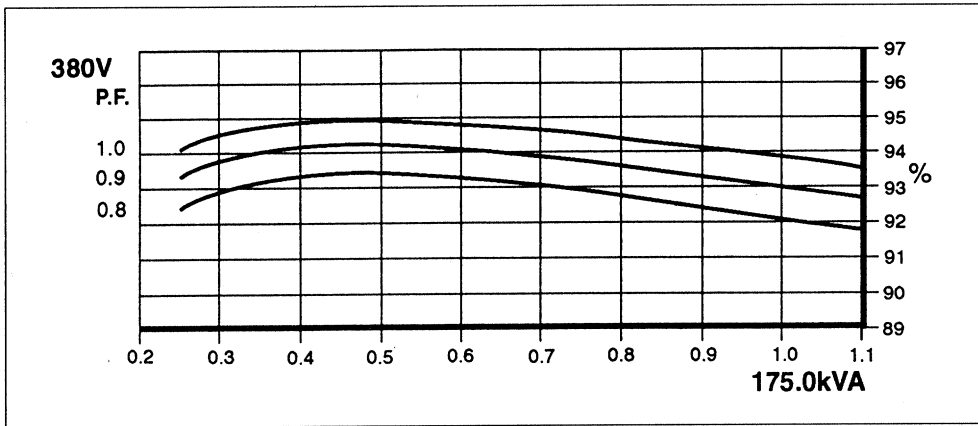

THREE PHASE EFFICIENCY CURVES

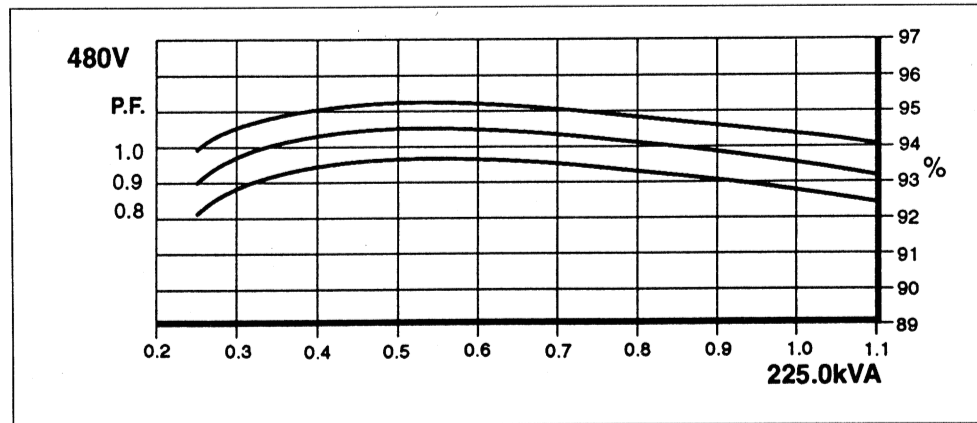
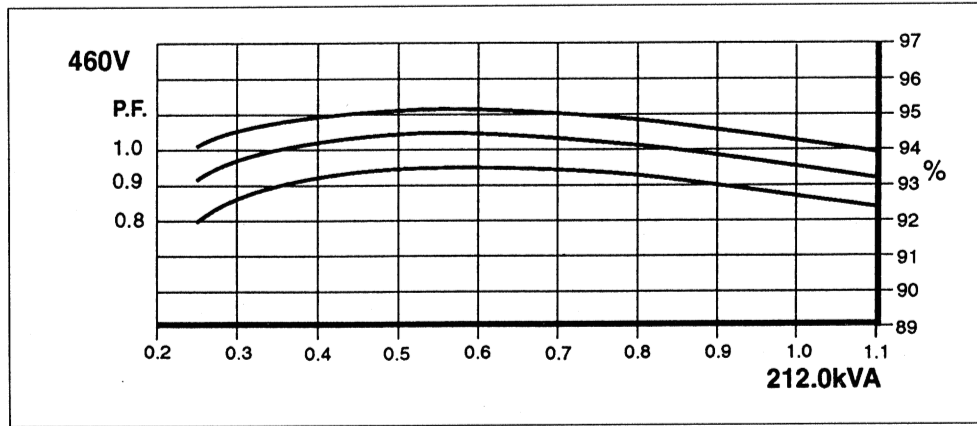
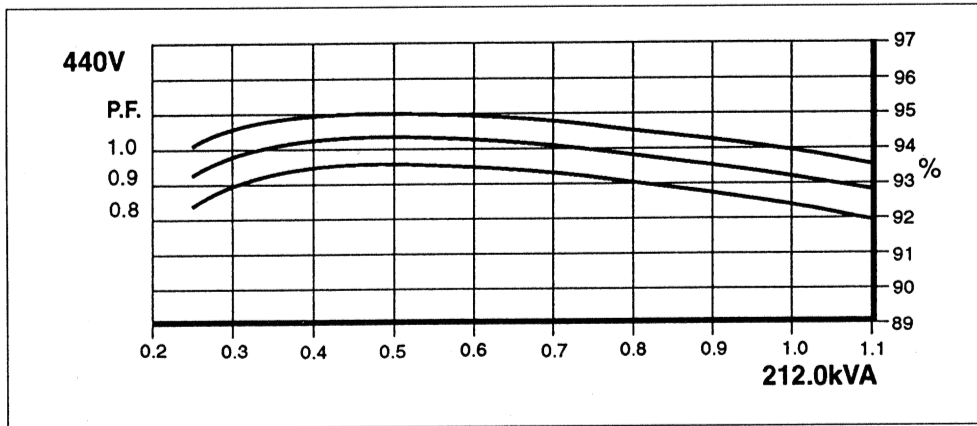
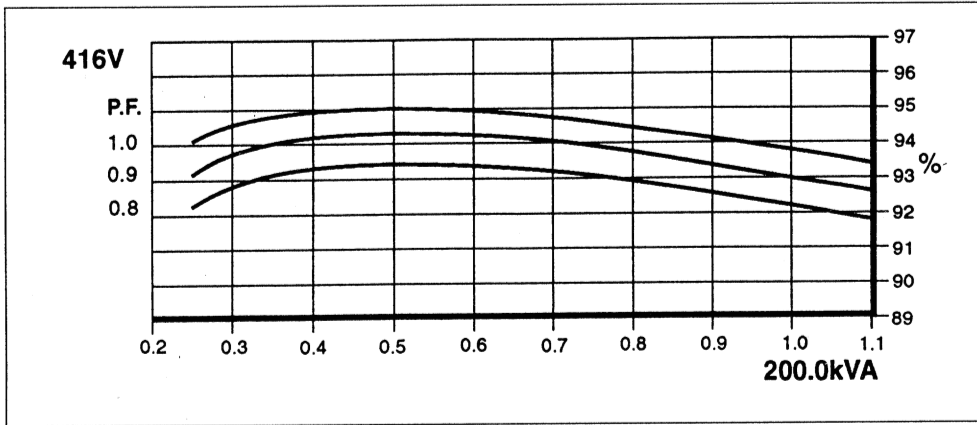

FRAME UC274G 50 HZ

SERIES THREE Three Phase Short Circuit Decrement Curve No-load Excitation at Rated Speed

Based on series star (wye) connection

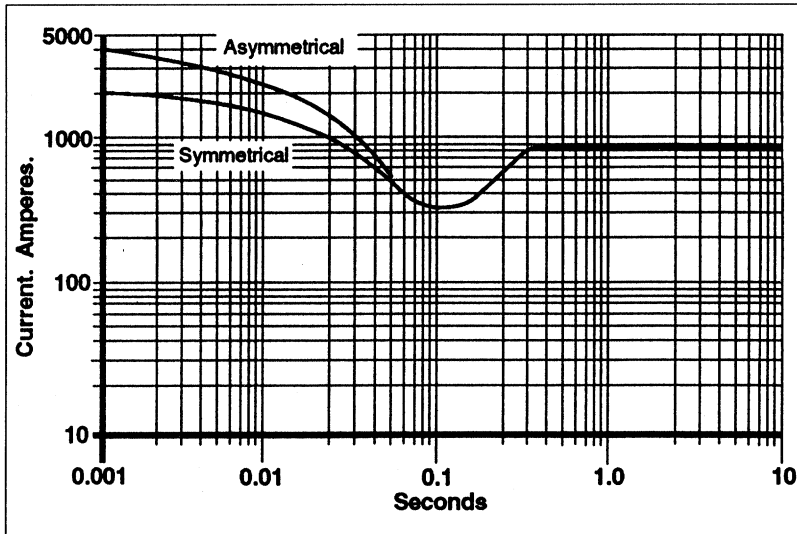

Note 1

The following multiplication factors should be used to adjust the values from curve between time 0.001 seconds and the minimum current point in respect of nominal operating voltage :

VOLTAGE	FACTOR
380 V	X 1.0
400 V	X 1.07
415 V	X 1.12
440 V	X 1.18

The sustained current value is constant irrespective of voltage level.

Note 2

The following multiplication factors should be used to convert the values calculated in accordance with NOTE 1 to those applicable to the various types of short circuit :

	3 PHASE	2 PHASE L-L	1 PHASE L-N
Instantaneous	X 1.00	X 0.87	X 1.30
Minimum	X 1.00	X 1.80	X 3.20
Sustained	X 1.00	X 1.50	X 2.50
Max. sustained duration	10 sec.	5 sec.	2 sec.

All other times are unchanged.

Note 3

Curves are drawn for Series Star (Wye) connected machines. For other connections the following multipliers should be applied to current values shown :

Parallel Star (Wye) Curve current value X 2
Series Delta (Δ) Curve current value X 1.732

Times are unchanged.

FRAME UC274G 60 HZ

SERIES THREE Three Phase Short Circuit Decrement Curve No-load Excitation at Rated Speed

Based on series star (wye) connection

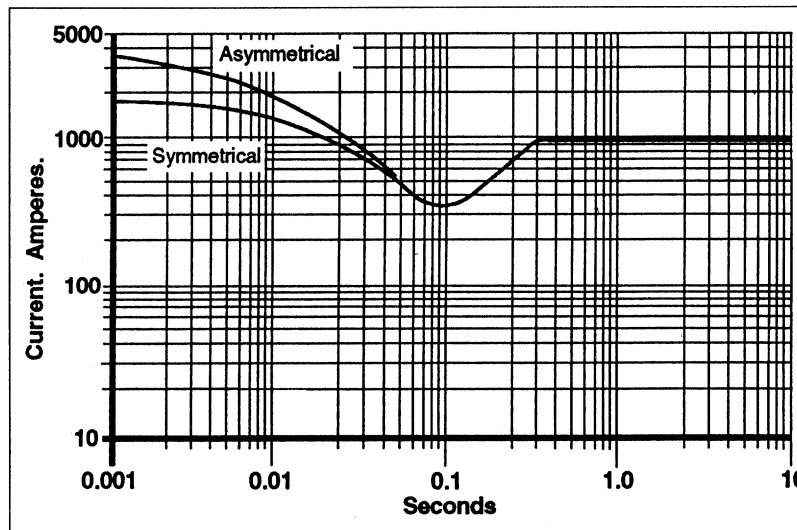

Note 1

The following multiplication factors should be used to adjust the values from curve between time 0.001 seconds and the minimum current point in respect of nominal operating voltage :

VOLTAGE	FACTOR
416 V	X 1.0
440 V	X 1.06
460 V	X 1.12
480 V	X 1.17

The sustained current value is constant irrespective of voltage level.

Note 2

The following multiplication factors should be used to convert the values calculated in accordance with NOTE 1 to those applicable to the various types of short circuit :

	3 PHASE	2 PHASE L-L	1 PHASE L-N
Instantaneous	X 1.00	X 0.87	X 1.30
Minimum	X 1.00	X 1.80	X 3.20
Sustained	X 1.00	X 1.50	X 2.50
Max. sustained duration	10 sec.	5 sec.	2 sec.

All other times are unchanged.

Note 3

Curves are drawn for Series Star (Wye) connected machines. For other connections the following multipliers should be applied to current values shown :

Parallel Star (Wye) Curve current value X 2
Series Delta (Δ) Curve current value X 1.732

Times are unchanged.

NEWAGE
INTERNATIONAL

NEWAGE INTERNATIONAL LIMITED

PO BOX 17, Barnack Road, Stamford, Lincolnshire PE9 2NB, England.

Telephone 44 (0) 1780 484000

Telex 32268 Cables Newage Stamford Fax 44 (0) 1780 484100

	CUMMINS ENGINE COMPANY, INC Columbus, Indiana 47201 ENGINE PERFORMANCE CURVE	Basic Engine Model: 6CTA8.3-G2	Curve Number: FR-90243 @ 1500 RPM FR-90242 @ 1800 RPM	G-DRIVE C8.3 1
		Engine Critical Parts List: CPL: 2218	Date: 17May99	
Displacement : 8.3 litre (505 in³)		Bore : 114 mm (4.49 in.) Stroke : 135 mm (5.32 in.)		
No. of Cylinders : 6		Aspiration : Turbocharged and Jacket Water Aftercooled		

•• PRELIMINARY ••

Engine Speed RPM	Standby Power		Prime Power		Continuous Power	
	kWm	BHP	kWm	BHP	kWm	BHP
1500	180	241	163	219	133	178
1800	207	277	188	252	159	213

Emissions Certification

This engine complies with certain emissions requirements established by US EPA/CARB and by the German TA-Luft. See Exhaust Emissions Data Sheet for conformance specifics.

Engine Performance Data @ 1500 RPM

OUTPUT POWER			FUEL CONSUMPTION			
%	kWm	BHP	kg/ kWm-h	lb/ BHP-h	litre/ hour	U.S. Gal/ hour
STANDBY POWER						
100	180	241	0.212	0.349	45	11.9
PRIME POWER						
100	163	219	0.210	0.345	40	10.7
75	122	164	0.207	0.340	30	7.9
50	82	110	0.210	0.345	20	5.3
25	41	55	0.229	0.377	11	2.9
CONTINUOUS POWER						
100	133	178	0.206	0.339	32	8.5

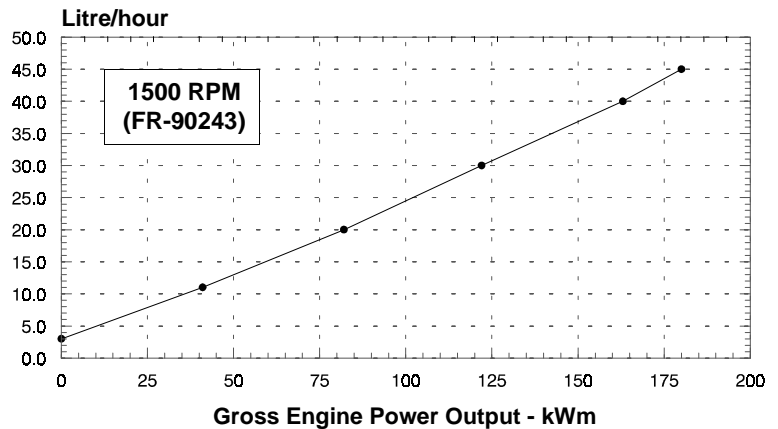

Engine Performance Data @ 1800 RPM

OUTPUT POWER			FUEL CONSUMPTION			
%	kWm	BHP	kg/ kWm-h	lb/ BHP-h	litre/ hour	U.S. Gal/ hour
STANDBY POWER						
100	207	277	0.219	0.361	53	14.1
PRIME POWER						
100	188	252	0.216	0.355	48	12.6
75	141	189	0.211	0.346	35	9.2
50	94	126	0.216	0.355	24	6.4
25	47	63	0.247	0.406	14	3.6
CONTINUOUS POWER						
100	159	213	0.213	0.350	40	10.5

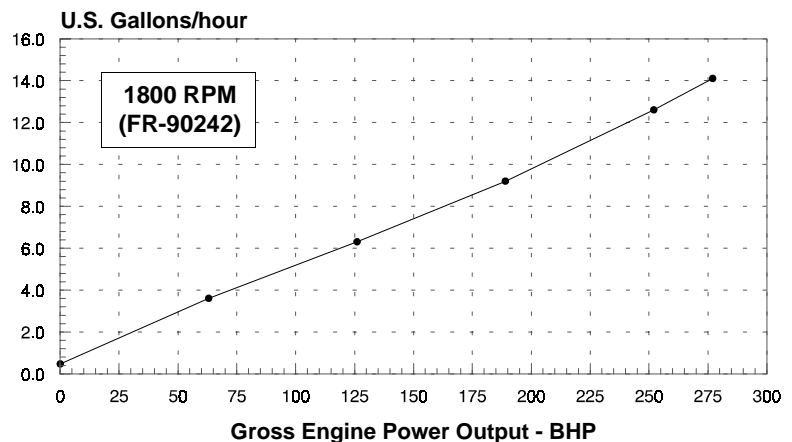

CONVERSIONS: (Litres = U.S. Gal x 3.785) (kWm = BHP x 0.746) (U.S. Gal = Litres x 0.2642) (BHP = kWm x 1.34)

Data shown above represent gross engine performance capabilities obtained and corrected in accordance with ISO-3046 conditions of 100 kPa (29.53 in Hg) barometric pressure [110 m (361 ft) altitude], 25 °C (77 °F) air inlet temperature, and relative humidity of 30% with No. 2 diesel or a fuel corresponding to ASTM D2. See reverse side for application rating guidelines.

The fuel consumption data is based on No. 2 diesel fuel weight at 0.85 kg/litre (7.1 lbs/U.S. gal).

Power output curves are based on the engine operating with fuel system, water pump and lubricating oil pump; not included are battery charging alternator, fan, optional equipment and driven components.

POWER RATING APPLICATION GUIDELINES FOR GENERATOR DRIVE ENGINES

These guidelines have been formulated to ensure proper application of generator drive engines in A.C. generator set installations. Generator drive engines are not designed for and shall not be used in variable speed D.C. generator set applications.

STANDBY POWER RATING is applicable for supplying emergency power for the duration of the utility power outage. No overload capability is available for this rating. Under no condition is an engine allowed to operate in parallel with the public utility at the Standby Power rating.

This rating should be applied where reliable utility power is available. A standby rated engine should be sized for a maximum of an 80% average load factor and 200 hours of operation per year. This includes less than 25 hours per year at the Standby Power rating. Standby ratings should never be applied except in true emergency power outages. Negotiated power outages contracted with a utility company are not considered an emergency.

CONTINUOUS POWER RATING is applicable for supplying utility power at a constant 100% load for an unlimited number of hours per year. No overload capability is available for this rating.

PRIME POWER RATING is applicable for supplying electric power in lieu of commercially purchased power. Prime Power applications must be in the form of one of the following two categories:

UNLIMITED TIME RUNNING PRIME POWER

Prime Power is available for an unlimited number of hours per year in a variable load application. Variable load should not exceed a 70% average of the Prime Power rating during any operating period of 250 hours.

The total operating time at 100% Prime Power shall not exceed 500 hours per year.

A 10% overload capability is available for a period of 1 hour within a 12 hour period of operation. Total operating time at the 10% overload power shall not exceed 25 hours per year.

LIMITED TIME RUNNING PRIME POWER

Prime Power is available for a limited number of hours in a non-variable load application. It is intended for use in situations where power outages are contracted, such as in utility power curtailment. Engines may be operated in parallel to the public utility up to 750 hours per year at power levels never to exceed the Prime Power rating. The customer should be aware, however, that the life of any engine will be reduced by this constant high load operation. Any operation exceeding 750 hours per year at the Prime Power rating should use the Continuous Power rating.

Reference Standards:

BS-5514 and DIN-6271 standards are based on ISO-3046.

Operation At Elevated Temperature And Altitude:

The engine may be operated at:

1800 RPM up to 5,000 ft (1525 m) and 104 °F (40 °C) without power deration.

1500 RPM up to 5,000 ft (1525 m) and 104 °F (40 °C) without power deration.

For sustained operation above these conditions, derate by 4% per 1,000 ft (300 m), and 1% per 10 °F (2% per 11 °C).

ENGINE MODEL : 6CTA8.3-G2

CONFIGURATION NUMBER : D413034GX02

DATA SHEET : DS-90242

DATE : 17May99

PERFORMANCE CURVE : FR-90243 @ 1500
FR-90242 @ 1800

INSTALLATION DIAGRAM

• Fan to Flywheel : 3170276

CPL NUMBER

• Engine Critical Parts List : 2218

GENERAL ENGINE DATA

Type	4-Cycle; In-line; 6-Cylinder Diesel
Aspiration	Turbocharged and Aftercooled
Bore x Stroke	4.49 x 5.32 (114 x 135)
Displacement	505 (8.3)
Compression Ratio	16.8 : 1
Dry Weight	
Fan to Flywheel Engine	1545 (702)
Heat Exchanger Cooled Engine	N/A
Wet Weight	
Fan to Flywheel Engine	1617 (735)
Heat Exchanger Cooled Engine	N/A
Moment of Inertia of Rotating Components	
• with FW 9232 Flywheel	37.6 (1.58)
Center of Gravity from Front Face of Block	21.3 (541)
Center of Gravity Above Crankshaft Centerline	6.4 (163)
Maximum Static Loading at Rear Main Bearing	N.A.

ENGINE MOUNTING

Maximum Bending Moment at Rear Face of Block	1000 (1356)
----------------------------------------------------	-------------

EXHAUST SYSTEM

Maximum Back Pressure	3 (76)
-----------------------------	--------

AIR INDUCTION SYSTEM

Maximum Intake Air Restriction		
• with Dirty Filter Element	25 (635)	
• with Normal Duty Air Cleaner and Clean Filter Element	10 (254)	
• with Heavy Duty Air Cleaner and Clean Filter Element	15 (381)	

COOLING SYSTEM

Coolant Capacity — Engine Only	3.25 (12.3)
— with HX — Heat Exchanger	N/A
Maximum Coolant Friction Head External to Engine	
— 1800 rpm	5 (35)
— 1500 rpm	4 (28)
Maximum Static Head of Coolant Above Engine Crank Centerline	60 (18.3)
Standard Thermostat (Modulating) Range	180 - 203 (82 - 95)
Minimum Pressure Cap	10 (69)
Maximum Top Tank Temperature for Standby / Prime Power	220 / 212 (104 / 100)
Minimum Raw Water Flow @ 90°F to HX — Heat Exchanger	N/A
Maximum Raw Water Inlet Pressure at HX — Heat Exchanger	N/A

LUBRICATION SYSTEM

Oil Pressure @ Idle Speed	15 (103)
@ Governed Speed	40 - 60 (276 - 414)
Maximum Oil Temperature	250 (121)
Oil Capacity with OP 9012 Oil Pan : High - Low	5 - 4 (18.9 - 15.1)
Total System Capacity (with Combo Filter)	6.3 (23.8)
Angularity of OP 9012 Oil Pan — Front Down	45°
— Front Up	45°
— Side to Side	45°

FUEL SYSTEM

Type Injection System	Bosch P3000 Direct Injection
Maximum Inlet Restriction at Lift Pump	4.0 (102) — in Hg (mm Hg)
Maximum Allowable Head on Injector Return Line (Consisting of Friction Head and Static Head)	10 (254) — in Hg (mm Hg)
Maximum Fuel Flow to Injection Pump.....	55 (208) — US gph (liter / hr)

ELECTRICAL SYSTEM

Cranking Motor (Heavy Duty, Positive Engagement).....	12	24
Battery Charging System, Negative Ground.....	63	40
Maximum Allowable Resistance of Cranking Circuit.....	0.00075	0.002
Minimum Recommended Battery Capacity		
• Cold Soak @ 50 °F (10 °C) and Above.....	— 0°F CCA	TBD
• Cold Soak @ 32 °F to 50 °F (0 °C to 10 °C)	— 0°F CCA	TBD
• Cold Soak @ 0 °F to 32 °F (-18 °C to 0 °C).....	— 0°F CCA	TBD

COLD START CAPABILITY

Minimum Ambient Temperature for Aided (with Coolant Heater) Cold Start within 10 seconds.....	— °F (°C)	TBD
Minimum Ambient Temperature for Unaided Cold Start.....	— °F (°C)	TBD

PERFORMANCE DATA

- All data is based on:
- Engine operating with fuel system, water pump, lubricating oil pump, air cleaner and exhaust silencer; not included are battery charging alternator, fan, and optional driven components.
 - Engine operating with fuel corresponding to grade No. 2-D per ASTM D975.
 - ISO 3046, Part 1, Standard Reference Conditions of:

Barometric Pressure	: 100 kPa (29.53 in Hg)	Air Temperature	: 25 °C (77 °F)
Altitude	: 110 m (361 ft)	Relative Humidity	: 30%

Steady State Stability Band at any Constant Load	— %	+/- 0.50
Estimated Free Field Sound Pressure Level of a Typical Generator Set;		
Excludes Exhaust Noise; at Rated Load and 7.5 m (24.6 ft); 1800 rpm / 1500 rpm.....	— dBA	N.A.
Exhaust Noise at 1 m Horizontally from Centerline of Exhaust Pipe Outlet Upwards at 45°.....	— dBA	N.A.

	STANDBY POWER		PRIME POWER	
	60 hz	50 hz	60 hz	50 hz
Governed Engine Speed	1800	1500	1800	1500
Engine Idle Speed.....	750 - 950	750 - 950	750 - 950	750 - 950
Gross Engine Power Output.....	277 (207)	241 (180)	252 (188)	219 (163)
Brake Mean Effective Pressure.....	242 (1669)	252 (1737)	220 (1517)	229 (1579)
Piston Speed	1596 (8.1)	1330 (6.8)	1596 (8.1)	1330 (6.8)
Friction Horsepower	30 (22)	23 (17)	30 (22)	23 (17)
Engine Water Flow at Stated Friction Head External to Engine:				
• 1 psi Friction Head.....	64 (4.0)	53 (3.3)	64 (4.0)	53 (3.3)
• Maximum Friction Head.....	55 (3.5)	45 (2.8)	55 (3.5)	45 (2.8)
Engine Data with Dry Type Exhaust Manifold				
Intake Air Flow.....	550 (259)	437 (206)	540 (255)	407 (192)
Exhaust Gas Temperature	1055 (569)	1046 (563)	955 (513)	996 (536)
Exhaust Gas Flow	1515 (715)	1225 (578)	1400 (660)	1100 (519)
Air to Fuel Ratio.....	23.7 : 1	22.3 : 1	26.1 : 1	23.2 : 1
Radiated Heat to Ambient	1850 (33)	1465 (26)	1645 (29)	1370 (24)
Heat Rejection to Coolant.....	6630 (117)	5415 (95)	6055 (107)	4695 (83)
Heat Rejection to Exhaust	10220 (180)	7900 (139)	8900 (157)	6985 (123)

Governed Engine Speed

Engine Idle Speed.....

Gross Engine Power Output..... — BHP (kW_m)

Brake Mean Effective Pressure..... — psi (kPa)

Piston Speed

Friction Horsepower

Engine Water Flow at Stated Friction Head External to Engine:

- 1 psi Friction Head..... — US gpm (liter / s)
- Maximum Friction Head..... — US gpm (liter / s)

Engine Data with Dry Type Exhaust Manifold

Intake Air Flow..... — cfm (liter / s)

Exhaust Gas Temperature

Exhaust Gas Flow

Air to Fuel Ratio..... — air : fuel

Radiated Heat to Ambient

Heat Rejection to Coolant..... — BTU / min (kW_m)

Heat Rejection to Exhaust

•• PRELIMINARY ••

N.A. - Data is Not Available
N/A - Not Applicable to this Engine
TBD - To Be Determined