



ottomotores

# CUMMINS SERIE KTA

Energía que Mueve al Mundo

## Definiciones

### Potencia Prime

Estos valores son aplicables para el suministro de energía eléctrica continua (a carga variable) en lugar de la red comercial + 10% sobrecarga

### Potencia Stand by

Estos valores son aplicables para el suministro de energía eléctrica continua (con carga variable) en caso de falla de la red comercial. No se permite sobrecarga sobre estos valores.

## Tabla de Potencias

Modelo	Voltaje	kVA Prime	kWe Prime	kVA Stand-by	kWe Stand-by
CNY1250	440-220V	1420	1136	1563	1250
CNY1500	440-220V	1705	1364	1875	1500

0.8 Factor de potencia



## Información Técnica

Technica Data	CNY1250	CNY1500
<b>Frecuencia:</b>	60 Hz	60 Hz
<b>Marca / Modelo</b>	KTA50G3	KTA50G9
<b>Generador Modelo:</b>	Stamford PI734A	Stamford PI734C
<b>Número de Cilindros:</b>	16 en "V"	16 en "V"
<b>Diametro por Carrera :in (mm)</b>	6.25 x 6.25 (159 x 159)	
<b>Relación de Compresión:</b>	13.9:1	13.9:1
<b>Aspiración:</b>	Turbocargado y Postenfriado	
<b>Velocidad:</b>	1800 RPM	1800 RPM
<b>Potencia: BHP(kWm)</b>	1850 (1380)	2220 (1656)
<b>Presion Efectiva: psi (kPA)</b>	265 (1827)	318 (2221)
<b>Velocidad dePiston: ft/min (m/s)</b>	1875 (9.5)	1875 (9.5)
<b>Consumo a plena carga: lt / hr - 100%</b>	330.00	392.00
<b>Calor Expulsado en el Sistema de Escape: BTU/min (kWm)</b>	53000 (935)	58925 (1040)
<b>Calor Expulsado en el Sistema de Enfriamiento: BTU/min (kWm)</b>	51000 (900)	19500 (345)
<b>Temperatura de Escape: °F (°C)</b>	887 (475)	960 (515)
<b>Flujo de Enfriamiento en el Radiador m³/seg - FPM</b>	call factory	call factory
<b>Flujo de Escape: cfm (liter/s)</b>	9100 (4295)	10650 (5025)

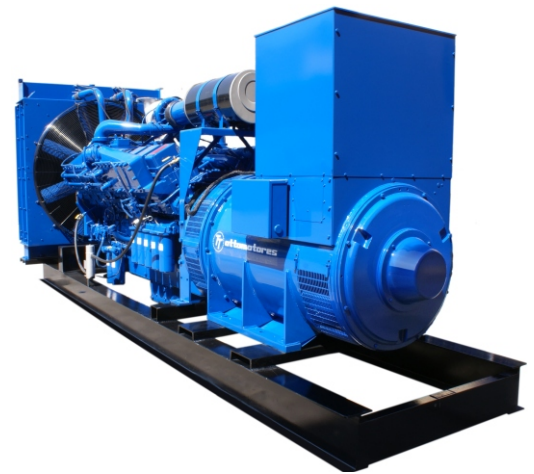

Nota: Imagen de carácter ilustrativa ya que los equipos en foto pudieran incluir accesorios opcionales

Como leer nuestro codigo: Ejem: CNY1250

C=Motor Cummins  
N=Generador Newage Stamford  
Y=60Hz-1800 RPM  
1250= Potencia del Equipo.



Ottomotores, S.A de C.V.

Calz. San Lorenzo No.1150  
Col. Cerro de la estrella, C.P. 09860  
Delg. Iztapalapa México, D.F.  
Tels:52-55-5624-5600

Fax: 52-55-5426-5521 / 52-55-5426-5581  
email: [ventas@ottomotores.com.mx](mailto:ventas@ottomotores.com.mx)

sitio web: [www.ottomotores.com.mx](http://www.ottomotores.com.mx)

# Dimensiones

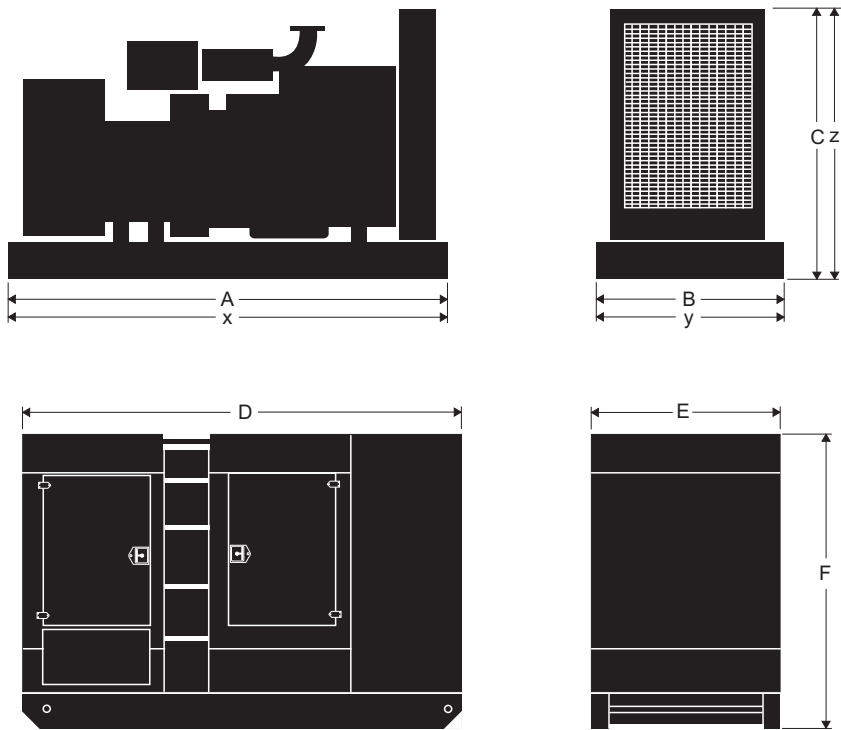

## Tabla de Dimensiones

Model	Equipo con Base Estructural			Equipo con Base Tanque			Equipo con Caseta Acústica*		
	A	B	C	x	y	z	D	E	F
CNY1250	528,00	200,50	239,46	☐			771,00	226,00	305,40
	Peso: 9325,00kgs								
CNY1600	595,00	207,00	235,64				Peso: 12948,00kgs		
	Peso: 10376,00 kgs								

☐ En proceso. Llame a Fabrica

[\*] Equipo opcional

## Información Técnica

Nota: las condiciones de referencia estándar son de 25 °C (77 ° F) temperatura de entrada de aire. Todos los datos de desempeño de motores son basados en la potencia mencionada arriba.

Datos de consumo de combustible a plena carga con combustible diesel tienen una gravedad específica de 0,85.

Comercializado por:

# Módulos de Control



Ottomotores tiene una posición única en la fabricación de grupos electrógenos utilizando en ellos módulos de control que cumplen con todos los niveles de requerimiento del mercado nacional y de exportación.



Las diferentes soluciones de controles que se tienen para nuestra gama de plantas generadoras, permite una operación simple en modo manual y automático, así mismo permiten desarrollar proyectos de sincronía entre plantas generadoras o con la red de energía eléctrica.



La familia de módulos de control en transición abierta ( DALE 3200 ) permite tener control en forma automática de la unidad de transferencia, así como el monitoreo del grupo generador.



Nuestro módulos de control cuentan con puerto de comunicación RS485 para la comunicación remota con el grupo generador.



Los módulos pueden ser monitoreados através de un excelente software para observar parámetros del equipo de manera fácil y rápida.



La familia de módulos de control para la sincronía (6100, 6050 y 6300), incorporan un amplio sistema de monitoreos además de conexión a Internet (LAN) o mensaje SMS vía celular, o usando los puertos de comunicación RS485 a través de ModBus



**ottomotores**

Energía que Mueve al Mundo

Calz. San Lorenzo No.1150  
Col. Cerro de la Estrella, C.P.09860  
Delegación Iztapalapa México D.F.  
Tels: 52-55-5624-5600  
Fax.52-55-5426-55-21 / 52-55-54265581

E-mail [ventas1@ottomotores.com.mx](mailto:ventas1@ottomotores.com.mx)  
[ventas2@ottomotores.com.mx](mailto:ventas2@ottomotores.com.mx)

Web site. [www.ottomotores.com.mx](http://www.ottomotores.com.mx)

© Ottomotores se reserva el derecho de hacer cambios sin previo aviso con el fin de mejorar nuestros productos 2010

MODELS  
CNE1430  
CNY1250

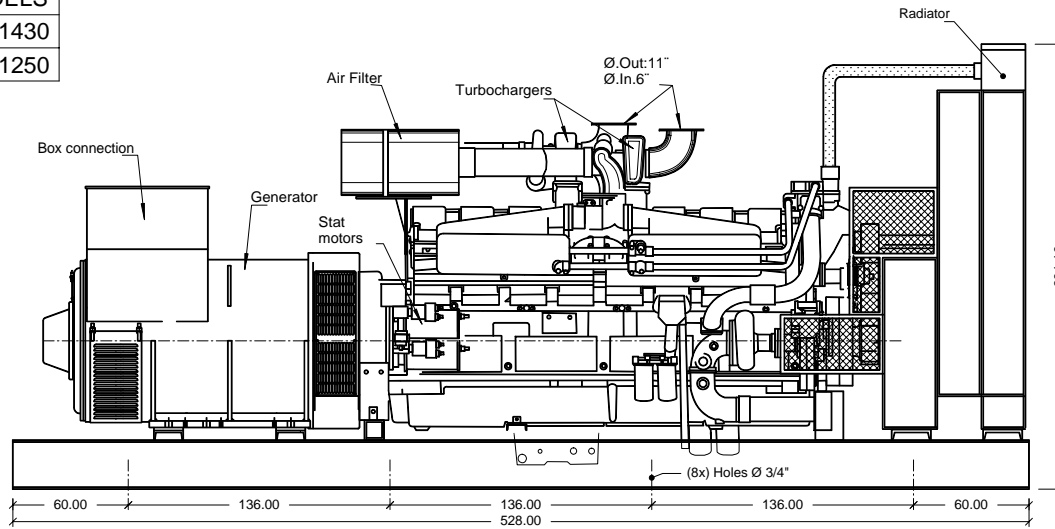

**SIDE VIEW**

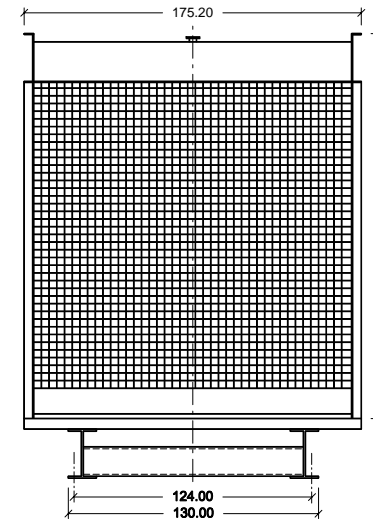

**FRONT VIEW**

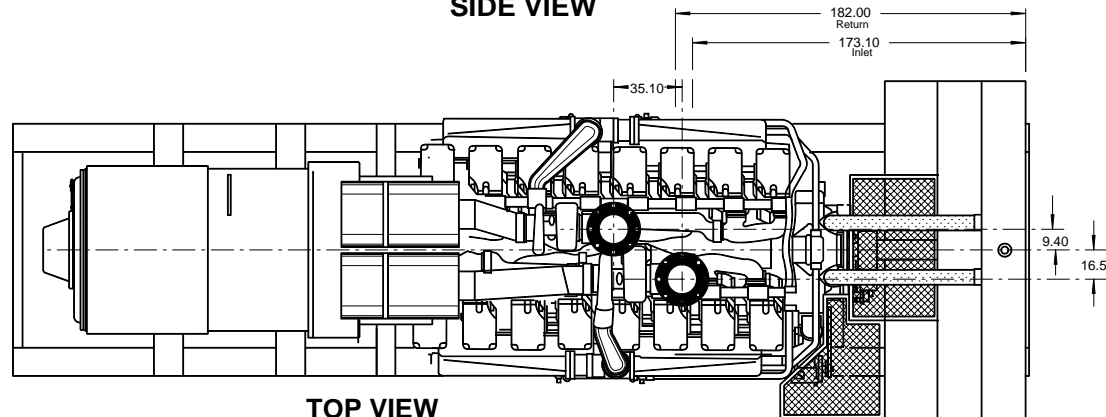

**TOP VIEW**

DESCRIPTION	
RADIATOR:	55705
ENGINE:	KTA 50 G3
AIR: FILTER:	AH1135 (2X)
BASE FRAME:	BP-KTA50G3-STF
# SPRING AVMS:	8 PZS

-THE GENSET DIMENSIONS ARE THE SAME BY FAMILY MODEL, THERE COULD BE ONLY DIFFERENCES ON THE ALTERNATOR LENGTH SEE SPECIFIC GENERAL ARRANGEMENT DRAWING OF CERTAIN MODEL  
-TOTAL WEIGHT COULD VARY CHECK RATING CHART FOR EACH MODEL

Customer:	S/O:

Rev.	Description	Date	Certificated

Title: <b>CUMMINS ENGINE KTA50G3 - STAMFORD ALTERNATOR</b>			
Draw: R.G.C.	Revised: F.H.M.	Certificated: F.H.M.	Code: <b>CNEY-16</b>
Date: JAN 05th 2005	Date: JAN 05th 2005	Date: JAN 05th 2005	Dept.: Engineering
		Marks: cms	Draw:
		Scale: s/e	Of:
Reviews			
Otomotors keeps the right to change the information with out prior notice			



**CUMMINS ENGINE COMPANY, INC**  
 Columbus, Indiana 47201  
**ENGINE PERFORMANCE CURVE**

Basic Engine Model:  
**KTA50-G3**

Curve Number:  
**FR-6250**

Page  
 No.

Engine Critical Parts List:  
**CPL: 2227**

Date:  
**12Jan01**

Displacement : **50.3 litre (3067 in<sup>3</sup>)**

Bore : **159 mm (6.25 in.)**      Stroke : **159 mm (6.25 in.)**

No. of Cylinders : **16**

Aspiration : **Turbocharged and Aftercooled**

Engine Speed	Standby Power Rating		Prime Power Rating				Continuous Power Rating	
			Limited Time		Unlimited Time			
RPM	kWm	BHP	kWm	BHP	kWm	BHP	kWm	BHP
1500	1227	1645	1150	1541	1097	1470	900	1206
1800	1380	1850	1300	1742	1220	1635	1000	1340

### Engine Performance Data @ 1500 RPM

OUTPUT POWER			FUEL CONSUMPTION			
%	kWm	BHP	kg/ kWm-h	lb/ BHP-h	litre/ hour	U.S. Gal/ hour
<b>STANDBY POWER</b>						
100	1227	1645	0.203	0.334	293	77.4
<b>PRIME -- LIMITED TIME RUNNING POWER</b>						
100	1150	1541	0.202	0.333	274	72.3
<b>PRIME -- UNLIMITED TIME RUNNING POWER</b>						
100	1097	1470	0.202	0.333	261	69.0
75	822	1102	0.206	0.338	199	52.5
50	548	735	0.216	0.355	139	36.6
25	275	368	0.234	0.385	76	20.0
<b>CONTINUOUS POWER</b>						
100	900	1206	0.204	0.336	216	57.1

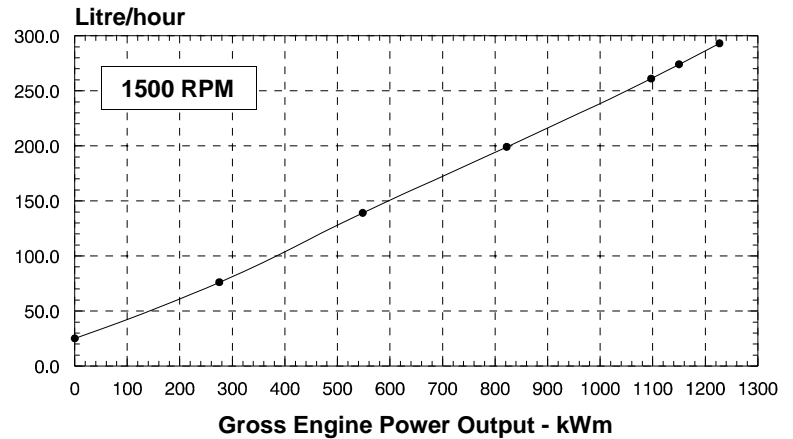

**CONVERSIONS:**    (Litres = U.S. Gal x 3.785)      (kWm = BHP x 0.746)      (U.S. Gal = Litres x 0.2642)      (BHP = Engine kWm x 1.34)

**These guidelines have been formulated to ensure proper application of generator drive engines in A.C. generator set installations. Generator drive engines are not designed for and shall not be used in variable speed D.C. generator set applications.**

**STANDBY POWER RATING**

Applicable for supplying emergency power for the duration of the utility power outage. No overload capability is available for this rating. Under no condition is an engine allowed to operate in parallel with the public utility at the Standby Power rating. This rating should be applied where reliable utility power is available. A Standby rated engine should be sized for a maximum of an 80% average load factor and 200 hours of operation per year. This includes less than 25 hours per year at the Standby Power rating. Standby ratings should never be applied except in true emergency power outages. Negotiated power outages contracted with a utility company are not considered an emergency.

**PRIME POWER RATING**

Applicable for supplying electric power in lieu of commercially purchased power. Prime Power applications must be in the form of one of the following two categories:

**UNLIMITED TIME RUNNING PRIME POWER**

Prime Power is available for an unlimited number of hours per year in a variable load application. Variable load should not exceed a 70% average of the Prime Power rating during any operating period of 250 hours. The total operating time at 100% Prime Power shall not exceed 500 hours per year. A 10% overload capability is available for a period of 1 hour within a 12-hour period of operation. Total operating time at the 10% overload power shall not exceed 25 hours per year.

**LIMITED TIME RUNNING PRIME POWER**

Limited Time Prime Power is available for a limited number of hours in a non-variable load application. It is intended for use in situations where power outages are contracted, such as in utility power curtailment. Engines may be operated in parallel to the public utility up to 750 hours per year at power levels never to exceed the Prime Power rating. The customer should be aware, however, that the life of any engine will be reduced by this constant high load operation. Any operation exceeding 750 hours per year at the Limited Time Prime Power rating should use the Continuous Power rating.

**CONTINUOUS POWER RATING**

Applicable for supplying utility power at a constant 100% load for an unlimited number of hours per year. No overload capability is available for this rating.

Data shown above represent gross engine performance capabilities obtained and corrected in accordance with ISO-3046 conditions of 100 kPa (29.5 in Hg) barometric pressure [110 m (361 ft) altitude], 25 °C (77 °F) air inlet temperature, and relative humidity of 30% with No. 2 diesel or a fuel corresponding to ASTM D2.

See reverse side for application rating guidelines.

The fuel consumption data is based on No. 2 diesel fuel weight at 0.85 kg/litre (7.1 lbs/U.S. gal).

Power output curves are based on the engine operating with fuel system, water pump and lubricating oil pump; not included are battery charging alternator, fan, optional equipment and driven components.

*D.K. Trueblood*



**CUMMINS ENGINE COMPANY, INC**  
 Columbus, Indiana 47201  
**ENGINE PERFORMANCE CURVE**

Basic Engine Model:  
**KTA50-G3**

Curve Number:  
**FR-6250**

Page No.

Engine Critical Parts List:  
**CPL: 2227**

Date:  
**12Jan01**

Displacement : **50.3 litre (3067 in<sup>3</sup>)**

Bore : **159 mm (6.25 in.)**      Stroke : **159 mm (6.25 in.)**

No. of Cylinders : **16**

Aspiration : **Turbocharged and Aftercooled**

Engine Speed	Standby Power Rating		Prime Power Rating				Continuous Power Rating	
			Limited Time		Unlimited Time			
RPM	kWm	BHP	kWm	BHP	kWm	BHP	kWm	BHP
1500	1227	1645	1150	1541	1097	1470	900	1206
1800	1380	1850	1300	1742	1220	1635	1000	1340

### Engine Performance Data @ 1800 RPM

OUTPUT POWER			FUEL CONSUMPTION			
%	kWm	BHP	kg/ kWm-h	lb/ BHP-h	litre/ hour	U.S. Gal/ hour
<b>STANDBY POWER</b>						
100	1380	1850	0.204	0.335	330	87.3
<b>PRIME -- LIMITED TIME RUNNING POWER</b>						
100	1300	1742	0.203	0.334	310	81.0
<b>PRIME -- UNLIMITED TIME RUNNING POWER</b>						
100	1220	1635	0.203	0.334	291	76.9
75	915	1226	0.207	0.340	222	58.7
50	610	818	0.220	0.361	157	41.6
25	305	409	0.249	0.410	89	23.6
<b>CONTINUOUS POWER</b>						
100	1000	1340	0.206	0.338	242	63.8

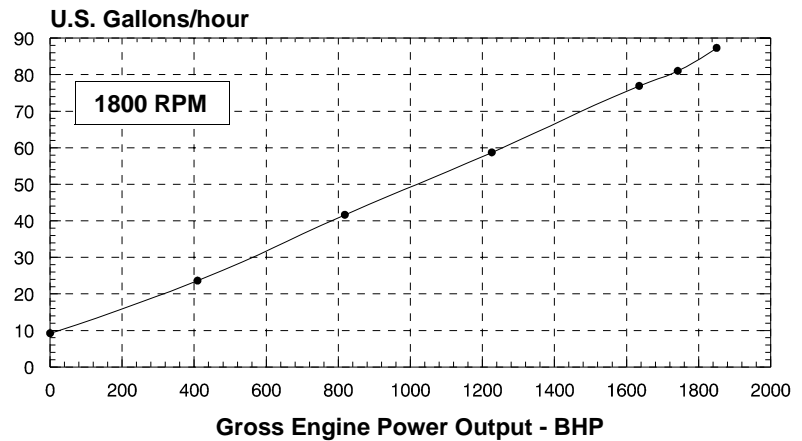

**CONVERSIONS:**    (Litres = U.S. Gal x 3.785)                      (kWm = BHP x 0.746)                      (U.S. Gal = Litres x 0.2642)                      (BHP = Engine kWm x 1.34)

**These guidelines have been formulated to ensure proper application of generator drive engines in A.C. generator set installations. Generator drive engines are not designed for and shall not be used in variable speed D.C. generator set applications.**

**STANDBY POWER RATING**  
 Applicable for supplying emergency power for the duration of the utility power outage. No overload capability is available for this rating. Under no condition is an engine allowed to operate in parallel with the public utility at the Standby Power rating. This rating should be applied where reliable utility power is available. A Standby rated engine should be sized for a maximum of an 80% average load factor and 200 hours of operation per year. This includes less than 25 hours per year at the Standby Power rating. Standby ratings should never be applied except in true emergency power outages. Negotiated power outages contracted with a utility company are not considered an emergency.

**PRIME POWER RATING**  
 Applicable for supplying electric power in lieu of commercially purchased power. Prime Power applications must be in the form of one of the following two categories:

**UNLIMITED TIME RUNNING PRIME POWER**  
 Prime Power is available for an unlimited number of hours per year in a variable load application. Variable load should not exceed a 70% average of the Prime Power rating during any operating period of 250 hours. The total operating time at 100% Prime Power shall not exceed 500 hours per year. A 10% overload capability is available for a period of 1 hour within a 12-hour period of operation. Total operating time at the 10% overload power shall not exceed 25 hours per year.

**LIMITED TIME RUNNING PRIME POWER**  
 Limited Time Prime Power is available for a limited number of hours in a non-variable load application. It is intended for use in situations where power outages are contracted, such as in utility power curtailment. Engines may be operated in parallel to the public utility up to 750 hours per year at power levels never to exceed the Prime Power rating. The customer should be aware, however, that the life of any engine will be reduced by this constant high load operation. Any operation exceeding 750 hours per year at the Limited Time Prime Power rating should use the Continuous Power rating.

**CONTINUOUS POWER RATING**  
 Applicable for supplying utility power at a constant 100% load for an unlimited number of hours per year. No overload capability is available for this rating.

Data shown above represent gross engine performance capabilities obtained and corrected in accordance with ISO-3046 conditions of 100 kPa (29.5 in Hg) barometric pressure [110 m (361 ft.) altitude], 25 °C (77 °F) air inlet temperature, and relative humidity of 30% with No. 2 diesel or a fuel corresponding to ASTM D2.

See reverse side for application rating guidelines.

The fuel consumption data is based on No. 2 diesel fuel weight at 0.85 kg/litre (7.1 lbs/U.S. gal).

Power output curves are based on the engine operating with fuel system, water pump and lubricating oil pump; not included are battery charging alternator, fan, optional equipment and driven components.

*D.K. Trueblood*

**TECHNICAL DATA DEPT.**

**CERTIFIED WITHIN 5%**

**CHIEF ENGINEER**

# KTA50-G3 Derate Curves @ 1500 RPM

CURVE NO : FR-6250  
DATE : 12Jan01

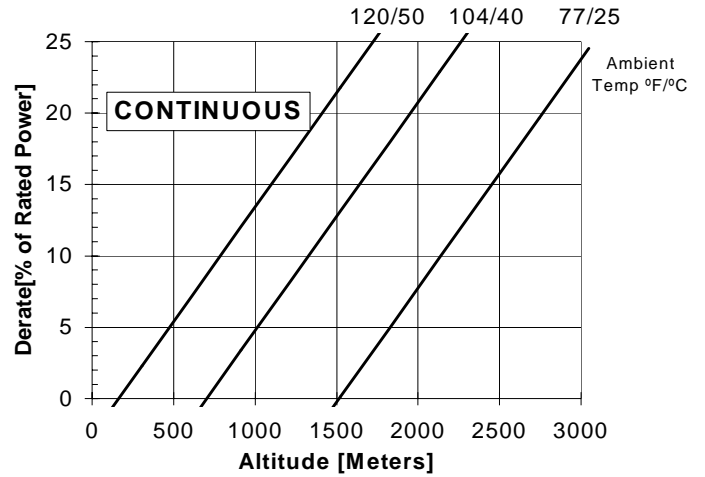
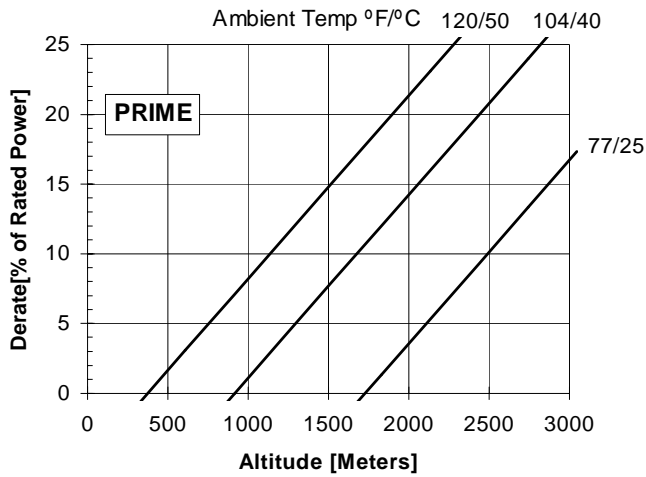
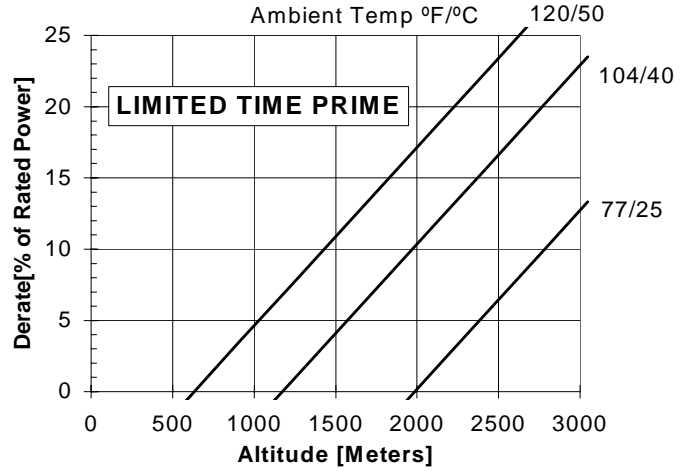
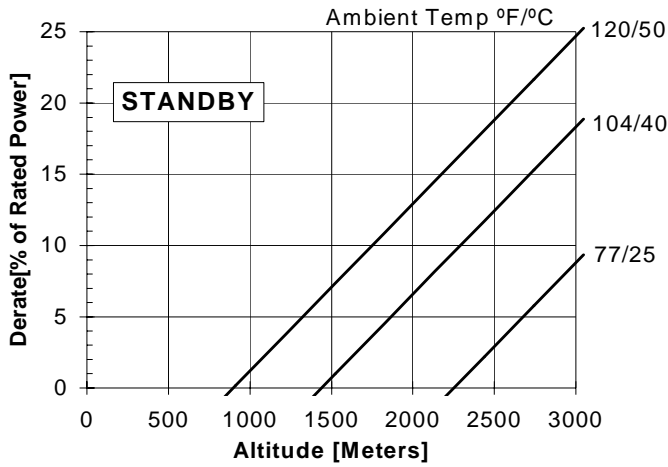

**NOTE:** Derates shown are based on 15 in H<sub>2</sub>O air intake restriction and 2 in Hg exhaust back pressure.

For sustained operation above these conditions, derate by an additional 5% per 1000 ft (300 m) and 9% per 18° F (10° C).

**Reference Standards:**

BS-5514 and DIN-6271 standards are based on ISO-3046.



**ELECTRICAL SYSTEM**

Cranking Motor (Heavy Duty, Positive Engagement) .....	— volt	24
Battery Charging System, Negative Ground .....	— ampere	35
Maximum Allowable Resistance of Cranking Circuit.....	— ohm	0.002
Minimum Recommended Battery Capacity		
• Cold Soak @ 50 °F (10 °C) and Above .....	— 0°F CCA	1280
• Cold Soak @ 32 °F to 50 °F (0 °C to 10 °C).....	— 0°F CCA	1800
• Cold Soak @ 0 °F to 32 °F (-18 °C to 0 °C).....	— 0°F CCA	1800

**COLD START CAPABILITY**

Minimum Ambient Temperature for Aided (with Coolant Heater) Cold Start within 10 seconds.....	— °F (°C)	50	(10)
Minimum Ambient Temperature for Unaided Cold Start.....	— °F (°C)	45	(7)

**PERFORMANCE DATA**

- All data is based on:
- Engine operating with fuel system, water pump, lubricating oil pump, air cleaner and exhaust silencer; not included are battery charging alternator, fan, and optional driven components.
  - Engine operating with fuel corresponding to grade No. 2-D per ASTM D975.
  - ISO 3046, Part 1, Standard Reference Conditions of:
 

Barometric Pressure	: 100 kPa (29.53 in Hg)	Air Temperature	: 25 °C (77 °F)
Altitude	: 110 m (361 ft)	Relative Humidity	: 30%

Steady State Stability Band at any Constant Load .....	— %	+/- 0.25
Estimated Free Field Sound Pressure Level of a Typical Generator Set;		
Excludes Exhaust Noise; at Rated Load and 7.5 m (24.6 ft); 1800 rpm / 1500 rpm.....	— dBA	94.6 / 92.4
Exhaust Noise at 1 m Horizontally from Centerline of Exhaust Pipe Outlet Upwards at 45°	— 1800 / 1500 rpm.....	dBA 126 / 125

Governed Engine Speed.....	— rpm
Engine Idle Speed .....	— rpm
Gross Engine Power Output.....	— BHP (kW <sub>m</sub> )
Brake Mean Effective Pressure .....	— psi (kPa)
Piston Speed.....	— ft / min (m / s)
Friction Horsepower .....	— HP (kW <sub>m</sub> )
Engine Water Flow at Stated Friction Head External to Engine:	
• 4 psi Friction Head.....	— US gpm (liter / s)
• Maximum Friction Head.....	— US gpm (liter / s)

	<b>STANDBY POWER</b>		<b>PRIME POWER UNLIMITED TIME</b>	
	<b>60 hz</b>	<b>50 hz</b>	<b>60 hz</b>	<b>50 hz</b>
Governed Engine Speed.....	1800	1500	1800	1500
Engine Idle Speed .....	725 - 775	725 - 775	725 - 775	725 - 775
Gross Engine Power Output.....	1850 (1380)	1645 (1227)	1635 (1220)	1470 (1097)
Brake Mean Effective Pressure .....	265 (1827)	283 (1951)	235 (1620)	253 (1744)
Piston Speed.....	1875 (9.5)	1562 (7.9)	1875 (9.5)	1562 (7.9)
Friction Horsepower .....	225 (168)	155 (116)	225 (168)	155 (116)
Engine Water Flow at Stated Friction Head External to Engine:				
• 4 psi Friction Head.....	535 (33.7)	440 (27.8)	535 (33.7)	440 (27.8)
• Maximum Friction Head.....	470 (29.6)	400 (25.2)	470 (29.6)	400 (25.2)
Intake Air Flow .....	3900 (1840)	3700 (1746)	3700 (1746)	3400 (1605)
Exhaust Gas Temperature.....	887 (475)	977 (525)	860 (460)	968 (520)
Exhaust Gas Flow .....	9100 (4295)	8500 (4011)	8400 (3964)	7900 (3728)
Air to Fuel Ratio .....	26.5 : 1	27.0 : 1	27.5 : 1	28.0 : 1
Radiated Heat to Ambient .....	10000 (176)	8500 (150)	8500 (150)	7300 (130)
Heat Rejection to Coolant .....	51000 (900)	44000 (775)	44000 (775)	38500 (680)
Heat Rejection to Exhaust.....	53000 (935)	48000 (845)	47000 (830)	43000 (760)

N.A. - Data is Not Available  
 N/A - Not Applicable to this Engine  
 TBD - To Be Determined

**ENGINE MODEL : KTA50-G3**  
**DATA SHEET : DS-6250**  
**DATE : 12Jan01**  
**CURVE NO. : FR-6250**

# KTA50-G3 Derate Curves @ 1800 RPM

CURVE NO : FR-6250

DATE : 12Jan01

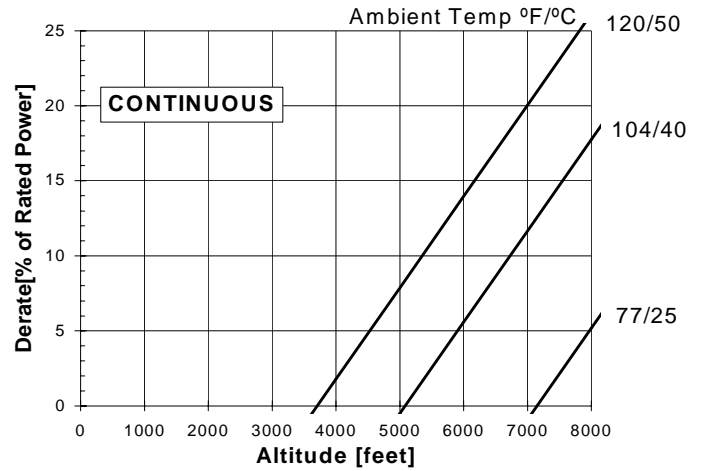
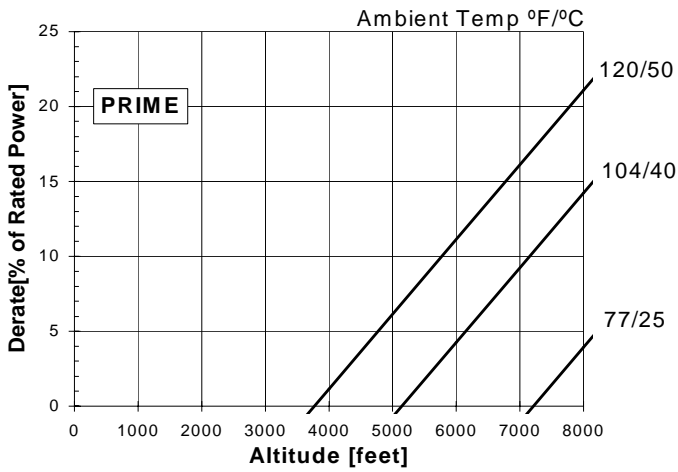
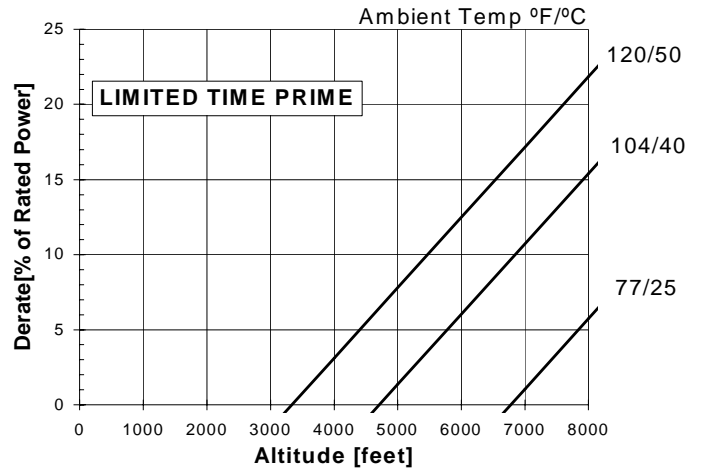
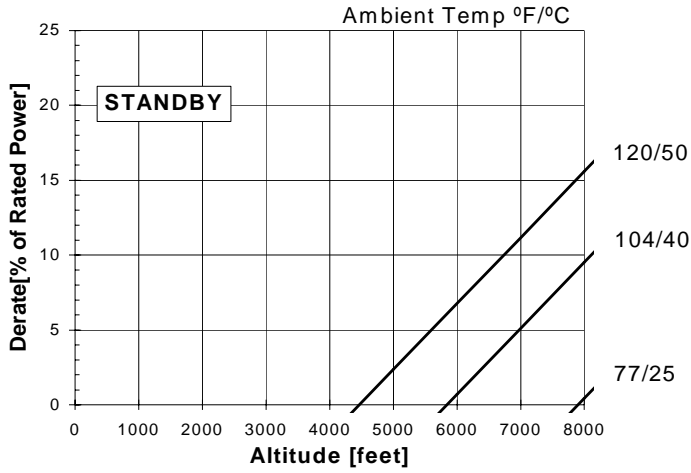

**NOTE:** Derates shown are based on 15 in H<sub>2</sub>O air intake restriction and 2 in Hg exhaust back pressure.

For sustained operation above these conditions, derate by an additional 6% per 1000 ft (300 m) and 8% per 18° F (10° C).

**Reference Standards:**

BS-5514 and DIN-6271 standards are based on ISO-3046.

**PI734A - Technical Data Sheet**

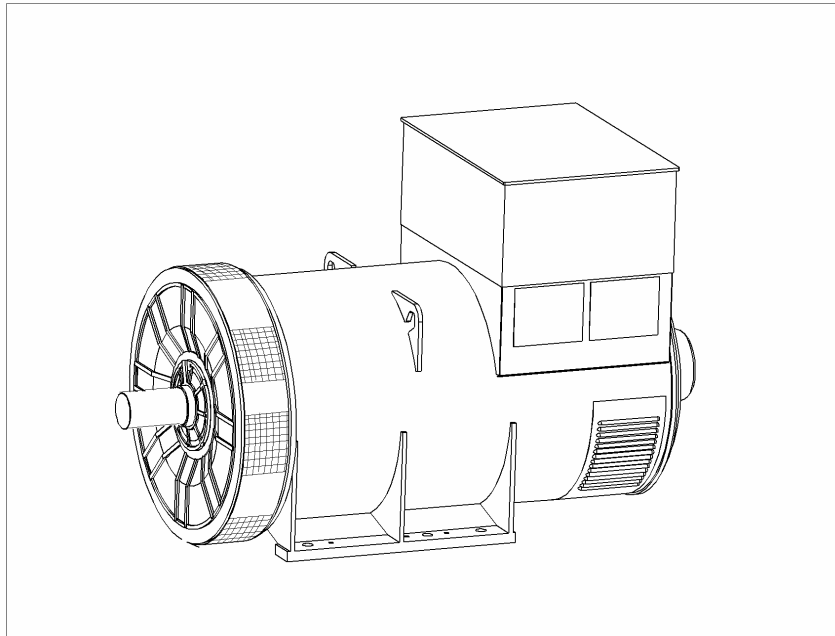

# PI734A

## SPECIFICATIONS & OPTIONS



### STANDARDS

Newage Stamford industrial generators meet the requirements of BS EN 60034 and the relevant sections of other national and international standards such as BS5000, VDE 0530, NEMA MG1-32, IEC60034, CSA C22.2-100, AS1359.

Other standards and certifications can be considered on request.

### DESCRIPTION

The STAMFORD PI range of synchronous ac generators are brushless with a rotating field. They are separately excited by the STAMFORD Permanent Magnet Generator (PMG). This is a shaft mounted, high frequency, pilot exciter which provides a constant supply of clean power via the Automatic Voltage Regulator (AVR) to the main exciter. The main exciter output is fed to the main rotor, through a full wave bridge rectifier, protected by surge suppression.

### VOLTAGE REGULATORS

The PI range generators complete with a PMG are available with one of two AVRs. Each AVR has soft start voltage build up and built in protection against sustained over-excitation, which will de-excite the generator after a minimum of 8 seconds.

Underspeed protection (UFRO) is also provided on both AVRs. The UFRO will reduce the generator output voltage proportional to the speed of the generator below a pre-settable level.

The **MX341 AVR** is two phase sensed with a voltage regulation of  $\pm 1\%$ . (see the note on regulation).

The **MX321 AVR** is 3 phase rms sensed with a voltage regulation of 0.5% rms (see the note on regulation). The UFRO circuit has adjustable slope and dwell for controlled recovery from step loads. An over voltage protection circuit will shutdown the output device of the AVR, it can also trip an optional excitation circuit breaker if required. As an option, short circuit current limiting is available with the addition of current transformers.

Both the MX341 and the MX321 need a generator mounted current transformer to provide quadrature droop characteristics for load sharing during parallel operation. Provision is also made for the connection of the STAMFORD power factor controller, for embedded applications, and a remote voltage trimmer.

### WINDINGS & ELECTRICAL PERFORMANCE

All generator stators are wound to 2/3 pitch. This eliminates triplen (3rd, 9th, 15th ...) harmonics on the voltage waveform and is found to be the optimum design for trouble-free supply of non-linear loads. The 2/3 pitch design avoids excessive neutral currents sometimes seen with higher winding pitches. A fully connected damper winding reduces oscillations during paralleling. This winding, with the 2/3 pitch and carefully selected pole and tooth designs, ensures very low levels of voltage waveform distortion.

### TERMINALS & TERMINAL BOX

Standard generators feature a main stator with 6 ends brought out to the terminals, which are mounted on the frame at the non-drive end of the generator. A sheet metal terminal box contains the AVR and provides ample space for the customers' wiring and gland arrangements. It has removable panels for easy access.

### SHAFT & KEYS

All generator rotors are dynamically balanced to better than BS6861:Part 1 Grade 2.5 for minimum vibration in operation. Two bearing generators are balanced with a half key.

### INSULATION/IMPREGNATION

The insulation system is class 'H', and meets the requirements of UL1446.

All wound components are impregnated with materials and processes designed specifically to provide the high build required for static windings and the high mechanical strength required for rotating components.

### QUALITY ASSURANCE

Generators are manufactured using production procedures having a quality assurance level to BS EN ISO 9001.

### NOTE ON REGULATION

The stated voltage regulation may not be maintained in the presence of certain radio transmitted signals. Any change in performance will fall within the limits of Criteria 'B' of EN 61000-6-2:2001. At no time will the steady-state voltage regulation exceed 2%.

NB Continuous development of our products entitles us to change specification details without notice, therefore they must not be regarded as binding.

Front cover drawing is typical of the product range.

**PI734A**  
**WINDING 312**

CONTROL SYSTEM	SEPARATELY EXCITED BY P.M.G.		
A.V.R.	MX341	MX321	
VOLTAGE REGULATION	± 1%	± 0.5 %	With 4% ENGINE GOVERNING
SUSTAINED SHORT CIRCUIT	REFER TO SHORT CIRCUIT DECREMENT CURVES (page 7)		

INSULATION SYSTEM	CLASS H							
PROTECTION	IP23							
RATED POWER FACTOR	0.8							
STATOR WINDING	DOUBLE LAYER LAP							
WINDING PITCH	TWO THIRDS							
WINDING LEADS	6							
MAIN STATOR RESISTANCE	0.0016 Ohms PER PHASE AT 22°C STAR CONNECTED							
MAIN ROTOR RESISTANCE	1.67 Ohms at 22°C							
EXCITER STATOR RESISTANCE	17.5 Ohms at 22°C							
EXCITER ROTOR RESISTANCE	0.048 Ohms PER PHASE AT 22°C							
R.F.I. SUPPRESSION	BS EN 61000-6-2 & BS EN 61000-6-4,VDE 0875G, VDE 0875N. refer to factory for others							
WAVEFORM DISTORTION	NO LOAD < 1.5% NON-DISTORTING BALANCED LINEAR LOAD < 5.0%							
MAXIMUM OVERSPEED	2250 Rev/Min							
BEARING DRIVE END	BALL. 6228 C3							
BEARING NON-DRIVE END	BALL. 6319 C3							
	1 BEARING				2 BEARING			
WEIGHT COMP. GENERATOR	2760 kg				2710 kg			
WEIGHT WOUND STATOR	1306 kg				1306 kg			
WEIGHT WOUND ROTOR	1139 kg				1077 kg			
WR <sup>2</sup> INERTIA	32.7498 kgm <sup>2</sup>				31.7489 kgm <sup>2</sup>			
SHIPPING WEIGHTS in a crate	2833kg				2779kg			
PACKING CRATE SIZE	194 x 105 x 154(cm)				194 x 105 x 154(cm)			
	50 Hz				60 Hz			
TELEPHONE INTERFERENCE	THF<2%				TIF<50			
COOLING AIR	2.69 m <sup>3</sup> /sec 5700 cfm				3.45 m <sup>3</sup> /sec 7300 cfm			
VOLTAGE STAR	380/220	400/231	415/240	440/254	416/240	440/254	460/266	480/277
kVA BASE RATING FOR REACTANCE VALUES	1225	1260	1260	1235	1370	1500	1510	1525
X <sub>d</sub> DIR. AXIS SYNCHRONOUS	3.51	3.26	3.02	2.64	4.23	4.14	3.81	3.53
X' <sub>d</sub> DIR. AXIS TRANSIENT	0.21	0.20	0.18	0.16	0.26	0.25	0.23	0.22
X'' <sub>d</sub> DIR. AXIS SUBTRANSIENT	0.16	0.15	0.14	0.12	0.19	0.19	0.17	0.16
X <sub>q</sub> QUAD. AXIS REACTANCE	2.26	2.10	1.95	1.70	2.73	2.67	2.46	2.28
X'' <sub>q</sub> QUAD. AXIS SUBTRANSIENT	0.32	0.29	0.27	0.24	0.38	0.37	0.34	0.32
X <sub>L</sub> LEAKAGE REACTANCE	0.04	0.04	0.03	0.03	0.05	0.05	0.04	0.04
X <sub>2</sub> NEGATIVE SEQUENCE	0.22	0.21	0.19	0.17	0.27	0.26	0.24	0.23
X <sub>0</sub> ZERO SEQUENCE	0.03	0.03	0.02	0.02	0.03	0.03	0.03	0.03
REACTANCES ARE SATURATED				VALUES ARE PER UNIT AT RATING AND VOLTAGE INDICATED				
T' <sub>d</sub> TRANSIENT TIME CONST.	0.13s							
T'' <sub>d</sub> SUB-TRANSTIME CONST.	0.01s							
T' <sub>do</sub> O.C. FIELD TIME CONST.	2.14s							
T <sub>a</sub> ARMATURE TIME CONST.	0.02s							
SHORT CIRCUIT RATIO	1/X <sub>d</sub>							

**50  
Hz**

**PI734A**  
Winding 312



**THREE PHASE EFFICIENCY CURVES**

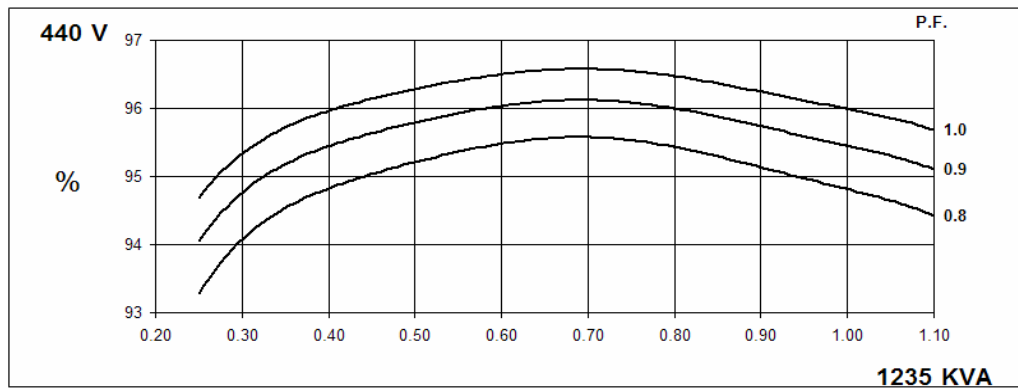
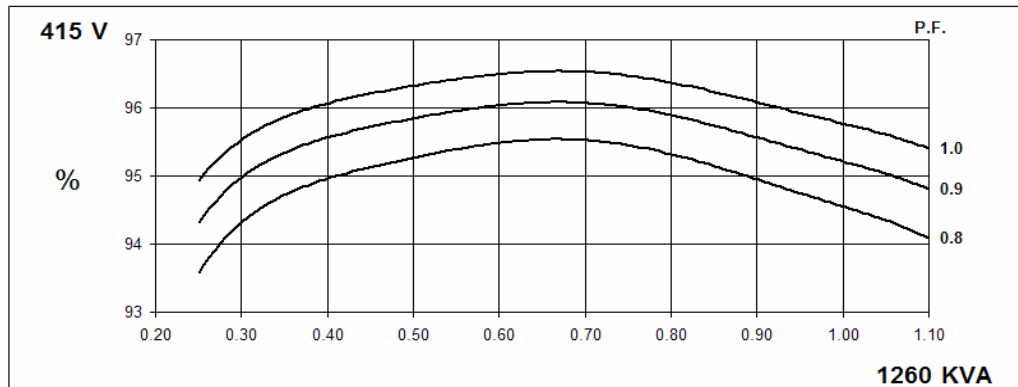
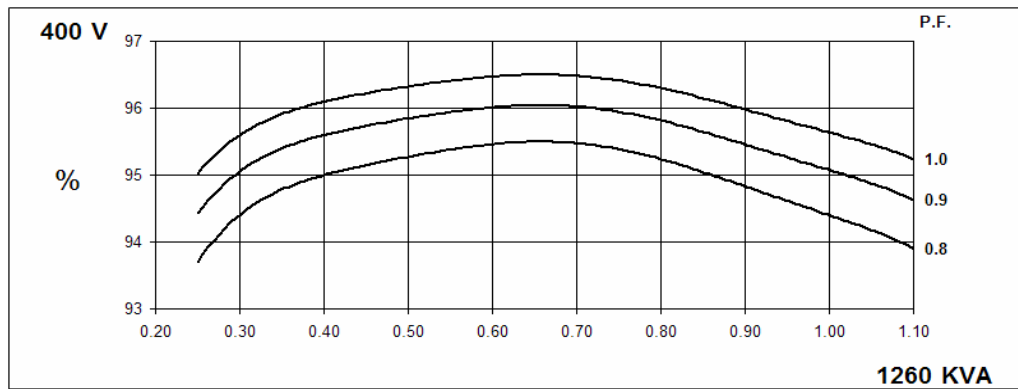
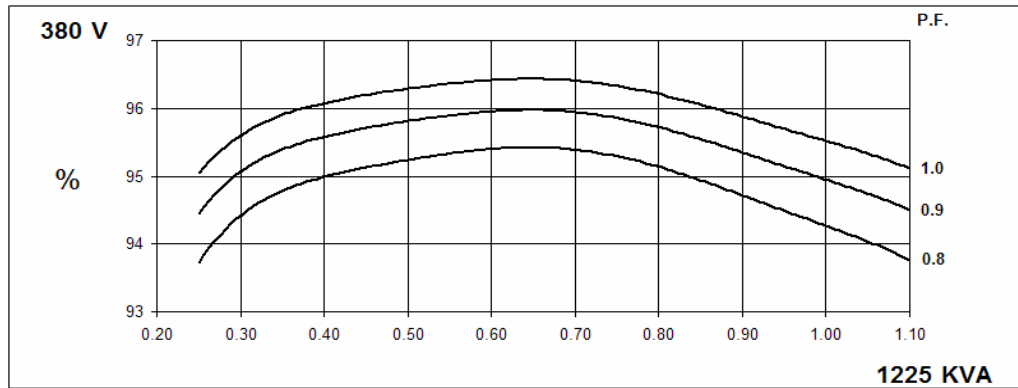

**THREE PHASE EFFICIENCY CURVES**

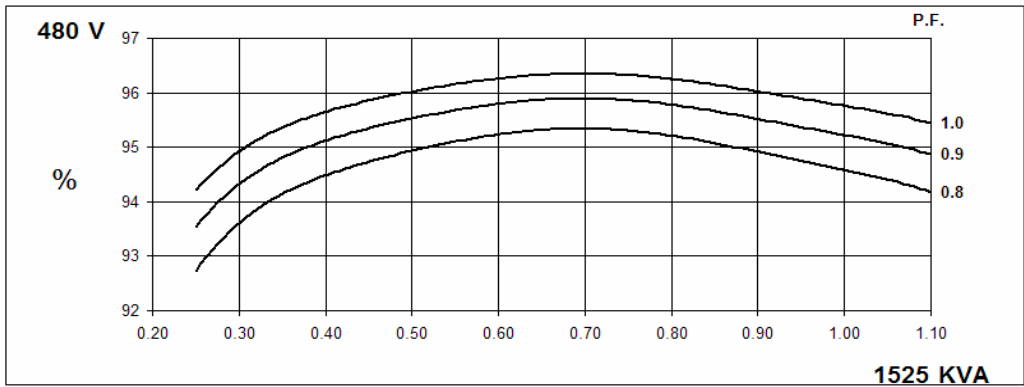
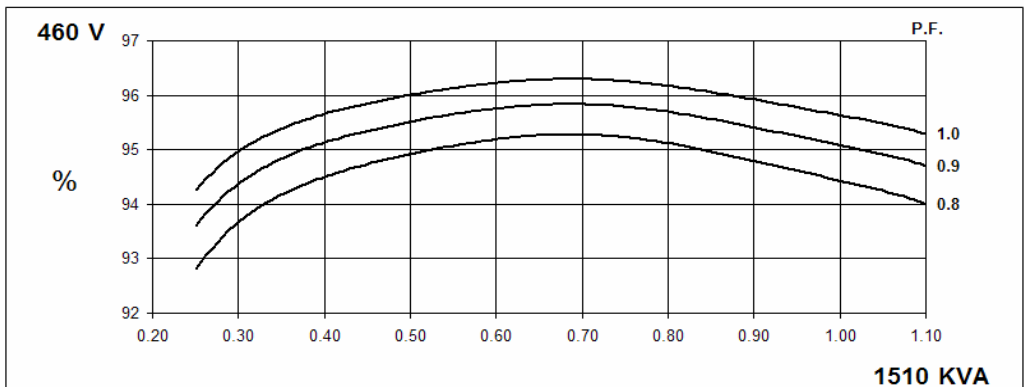
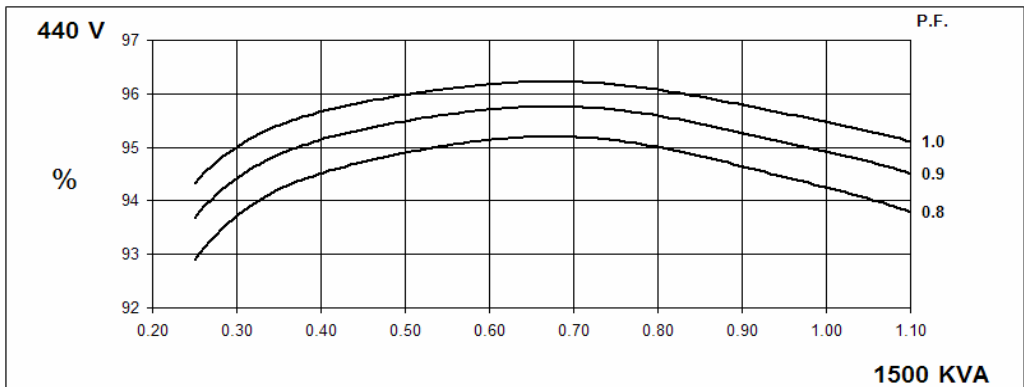
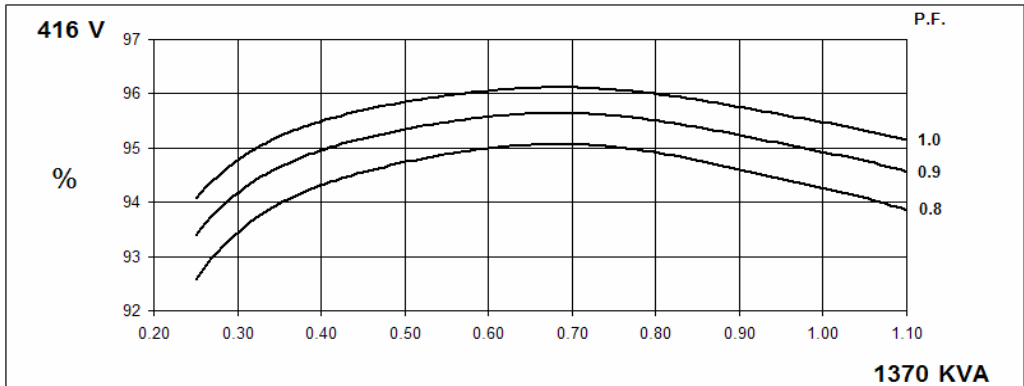

**PI734A**  
Winding 312



**Locked Rotor Motor Starting Curve**

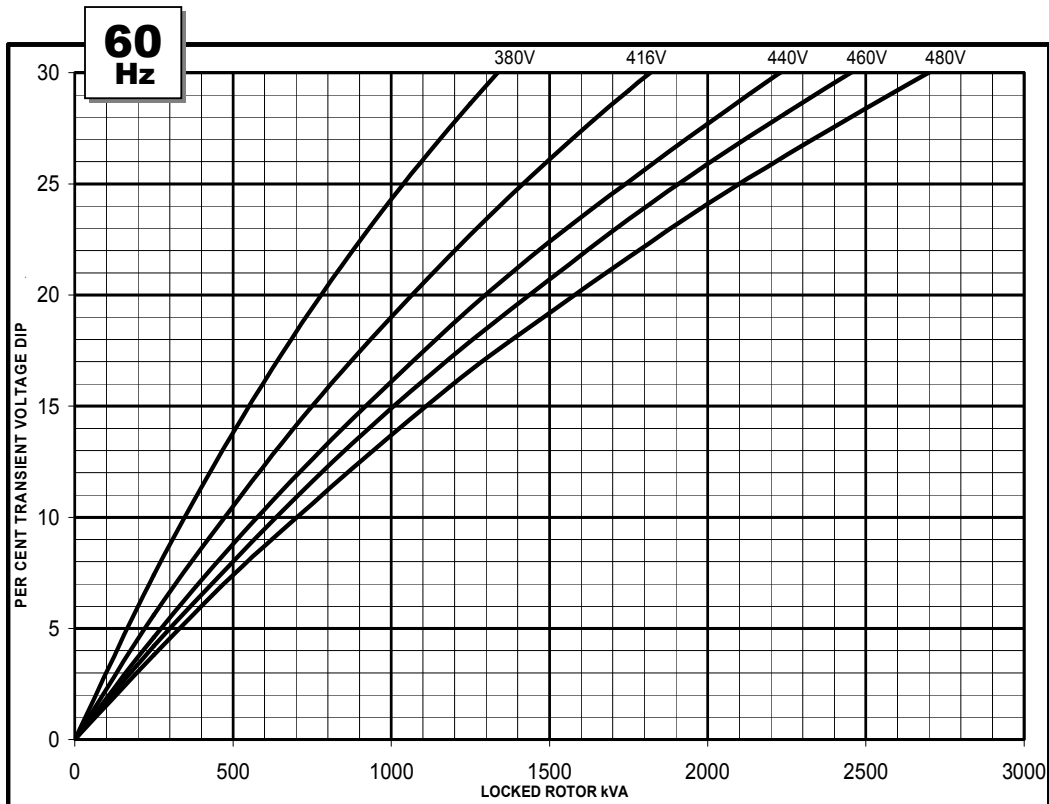

**Three-phase Short Circuit Decrement Curve. No-load Excitation at Rated Speed  
Based on star (wye) connection.**

**50  
Hz**

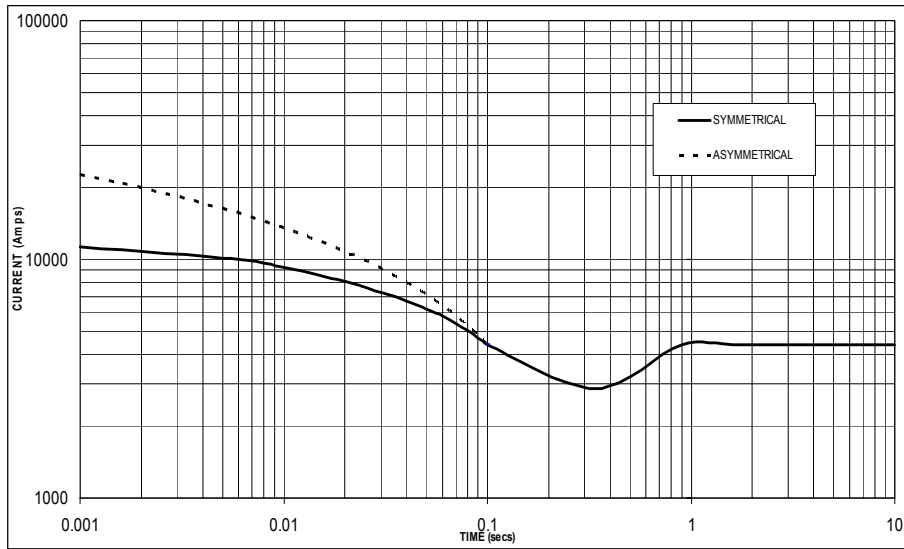

Sustained Short Circuit = 4,400 Amps

**60  
Hz**

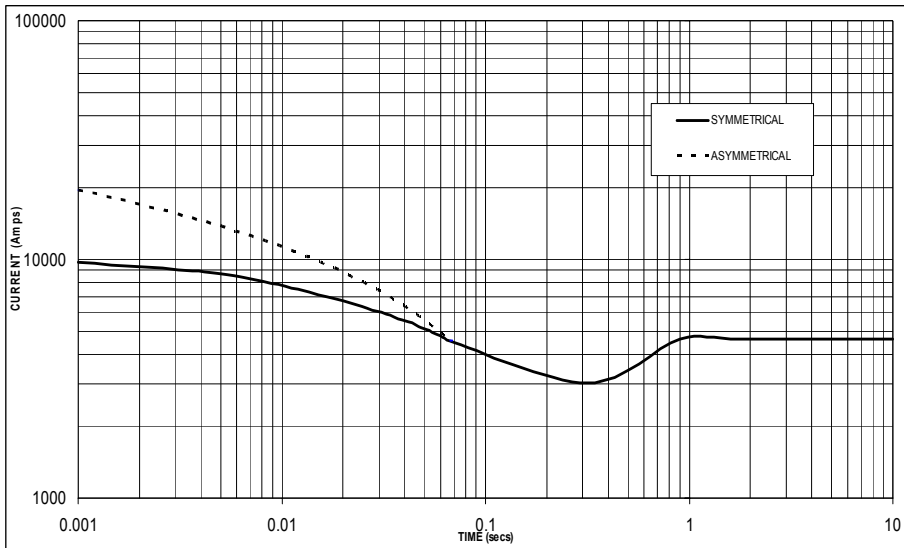

Sustained Short Circuit = 4,650 Amps

**Note 1**

The following multiplication factors should be used to adjust the values from curve between time 0.001 seconds and the minimum current point in respect of nominal operating voltage :

50Hz		60Hz	
Voltage	Factor	Voltage	Factor
380v	x 1.00	416v	x 1.00
400v	x 1.05	440v	x 1.06
415v	x 1.09	460v	x 1.10
440v	x 1.16	480v	x 1.15

The sustained current value is constant irrespective of voltage level

**Note 2**

The following multiplication factor should be used to convert the values calculated in accordance with NOTE 1 to those applicable to the various types of short circuit :

	3-phase	2-phase L-L	1-phase L-N
Instantaneous	x 1.00	x 0.87	x 1.30
Minimum	x 1.00	x 1.80	x 3.20
Sustained	x 1.00	x 1.50	x 2.50
Max. sustained duration	10 sec.	5 sec.	2 sec.

All other times are unchanged

**Note 3**

Curves are drawn for Star (Wye) connected machines.

# PI734A

Winding 312 / 0.8 Power Factor



## RATINGS

Class - Temp Rise		Cont. F - 105/40°C				Cont. H - 125/40°C				Standby - 150/40°C				Standby - 163/27°C			
<b>50Hz</b>	Star (V)	380	400	415	440	380	400	415	440	380	400	415	440	380	400	415	440
	kVA	1140	1175	1175	1150	1225	1260	1260	1235	1275	1315	1315	1290	1310	1350	1350	1325
	kW	912	940	940	920	980	1008	1008	988	1020	1052	1052	1032	1048	1080	1080	1060
	Efficiency (%)	94.5	94.6	94.8	95.0	94.3	94.4	94.6	94.8	94.1	94.2	94.4	94.7	94.0	94.1	94.3	94.6
	kW Input	965	994	992	968	1039	1068	1066	1042	1084	1117	1114	1090	1115	1148	1145	1121

<b>60Hz</b>	Star (V)	416	440	460	480	416	440	460	480	416	440	460	480	416	440	460	480
	kVA	1275	1395	1405	1415	1370	1500	1510	1525	1425	1560	1570	1585	1465	1605	1615	1630
	kW	1020	1116	1124	1132	1096	1200	1208	1220	1140	1248	1256	1268	1172	1284	1292	1304
	Efficiency (%)	94.5	94.5	94.6	94.8	94.3	94.2	94.4	94.6	94.1	94.1	94.3	94.5	94.0	94.0	94.2	94.4
	kW Input	1079	1181	1188	1194	1162	1274	1280	1290	1211	1326	1332	1342	1247	1366	1372	1381

## DIMENSIONS

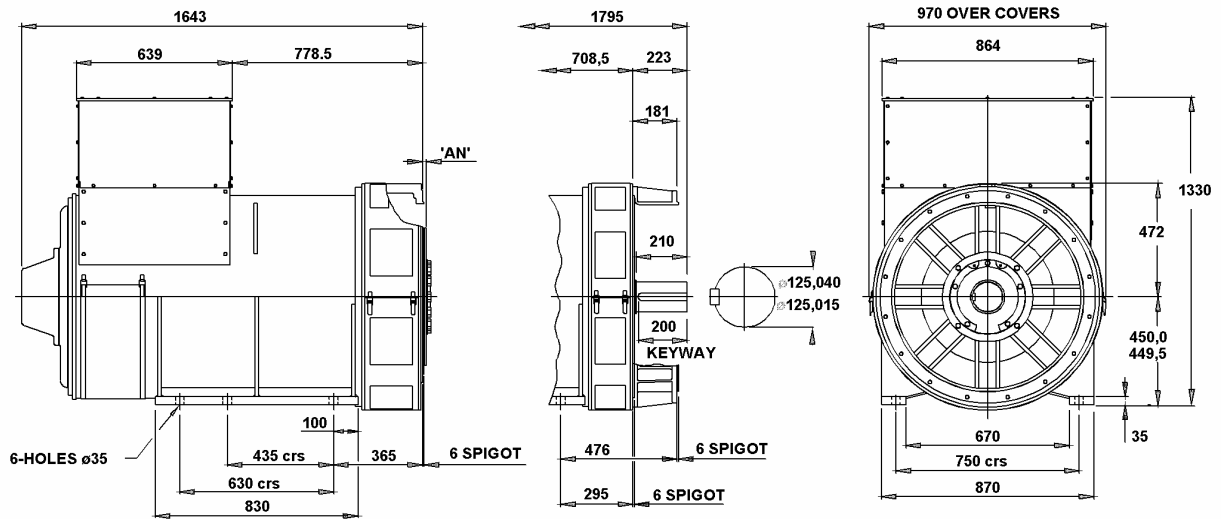

COUPLING DISC	'AN'
S.A.E No 18	15,7
S.A.E No 21	0
S.A.E No 24	0

1-BRG ADAPTORS
S.A.E No 0
S.A.E No 00

2-BRG ADAPTORS
S.A.E No 0
S.A.E No 00



Barnack Road • Stamford • Lincolnshire • PE9 2NB  
 Tel: 00 44 (0)1780 484000 • Fax: 00 44 (0)1780 484100  
 Website: [www.newage-avkseg.com](http://www.newage-avkseg.com)