



ottomotores

CUMMINS SERIE 6B

Energía que Mueve al Mundo

Definiciones

Potencia Prime

Estos valores son aplicables para el suministro de energía eléctrica continua (a carga variable) en lugar de la red comercial + 10% sobrecarga

Potencia Stand by

Estos valores son aplicables para el suministro de energía eléctrica continua (con carga variable) en caso de falla de la red comercial. No se permite sobrecarga sobre estos valores.

Tabla de Potencias

Modelo	Voltaje	kVA Prime	kWe Prime	kVA Stand-by	kWe Stand-by
CNY100	220-440V	114	91	125	100
CNY125	220-440V	142	114	156	125

0.8 Factor de potencia

Información Técnica

Datos Técnicos	CNY100	CNY125
Frecuencia:	60 Hz	60 Hz
Marca / Modelo	Cummins 6BTA5.9G3	Cummins 6BTA5.9G3
Generador Modelo:	Stamford UCI274C	Stamford UCI274E
Número de Cilindros:	6 en línea	6 en línea
Diametro por Carrera :in (mm)	4.02X4.72 (102X120)	4.02X4.72 (102X120)
Relación de Compresión:	16.5 : 1	16.5 : 1
Aspiración:	turbo y postenfriado	turbo y postenfriado
Velocidad:	1800 RPM	1800 RPM
Potencia: BHP(kWm)	177 (132)	207 (154)
Presion Efectiva: psi (kPA)	254 (1752)	254 (1752)
Velocidad de Piston: ft/min (m/s)	1416 (7.2)	1416 (7.2)
Consumo a plena carga: lt / hr - 100%	36.00	36.00
Calor Expulsado en el Sistema de Escape: BTU/min (kWm)	7376 (129.6)	7376 (129.6)
Calor Expulsado en el Sistema de Enfriamiento: BTU/min (kWm)	4534 (79.7)	4534 (79.7)
Temperatura de Escape: °F (°C)	991 (533)	991 (533)
Flujo de Enfriamiento en el Radiador m³/seg - FPM	llame a fabrica	llame a fabrica
Flujo de Escape: cfm (liter/s)	1049 (479)	1049 (479)



Nota: Imagen de carácter ilustrativa ya que los equipos en foto pudieran incluir accesorios opcionales



Como leer nuestro codigo: Ejem: CNY100

C=Motor Cummins
N=Generador Newage Stamford
Y=60Hz-1800 RPM
100= Potencia del Equipo.



LAPEM

Ottomotores, S.A de C.V.

Calz. San Lorenzo No.1150
Col. Cerro de la estrella, C.P. 09860
Delg. Iztapalapa México, D.F.
Tels:52-55-5624-5600

Fax: 52-55-5426-5521 / 52-55-5426-5581
email: ventas@ottomotores.com.mx

www.ottomotores.com.mx

Dimensiones



Tabla de Dimensiones

CNY100 CNY125	Equipo con Base Estructural			Equipo con Base Tanque			Equipo con Caseta Acústica*		
	A	B	C	x	y	z	D	E	F
C.pack	220,00	71,00	135,00	260,00	109,00	163,41	326,00	109,00	185,00
	Peso: 977,00 kgs			Peso: 1440,00 kgs			Peso: 1961,00kgs		

[*] Equipo opcional

Información Técnica

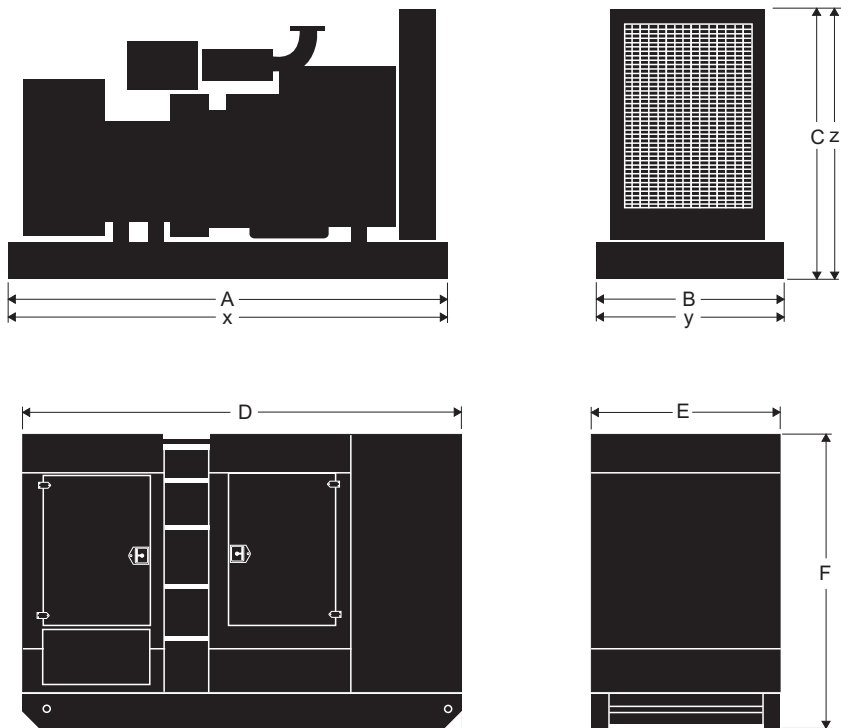
Nota: las condiciones de referencia estándar son de 25 °C (77 ° F) temperatura de entrada de aire. Todos los datos de desempeño de motores son basados en la potencia mencionada arriba.

Datos de consumo de combustible a plena carga con combustible diesel tienen una gravedad específica de 0,85.

Comercializado por:

Módulos de Control



Ottomotores tiene una posición única en la fabricación de grupos electrógenos utilizando en ellos módulos de control que cumplen con todos los niveles de requerimiento del mercado nacional y de exportación.



Las diferentes soluciones de controles que se tienen para nuestra gama de plantas generadoras, permite una operación simple en modo manual y automático, así mismo permiten desarrollar proyectos de sincronía entre plantas generadoras o con la red de energía eléctrica.



La familia de módulos de control en transición abierta (DALE 3200) permite tener control en forma automática de la unidad de transferencia, así como el monitoreo del grupo generador.



Nuestro módulos de control cuentan con puerto de comunicación RS485 para la comunicación remota con el grupo generador.



La familia de módulos de control para la sincronía (6100, 6050 y 6300), incorporan un amplio sistema de monitoreos además de conexión a Internet (LAN) o mensaje SMS vía celular, o usando los puertos de comunicación RS485 a través de ModBus



ottomotores

Energía que Mueve al Mundo

Calz. San Lorenzo No.1150
Col. Cerro de la Estrella, C.P.09860
Delegación Iztapalapa México D.F.
Tels: 52-55-5624-5600
Fax.52-55-5426-55-21 / 52-55-54265581

E-mail ventas1@ottomotores.com.mx
ventas2@ottomotores.com.mx

Web site. www.ottomotores.com.mx

6BT5.9-G6

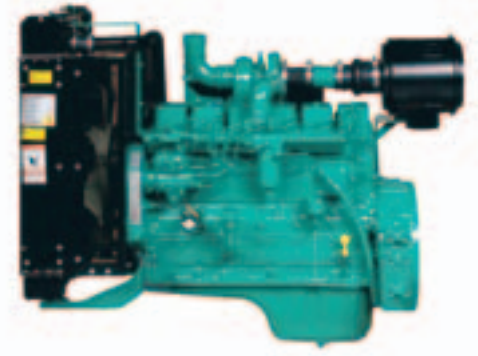

> Specification sheet



Our energy working for you.™

Description

The B5.9 engine has established an unrivalled reputation for reliability, incorporating features designed to maximise engine integration within OEM installation.



This engine has been built to comply with CE certification.



This engine has been designed in facilities certified to ISO9001 and manufactured in facilities certified to ISO9001 or ISO9002.

Features

Coolpac Integrated Design - Supplied with cooling package and air cleaner kit for a complete power package.

Single Poly Vee belt drive for fan, alternator and water pump, with self-tensioning idler for minimum maintenance.

Stanadyne DB4 injection pump features advance mechanism for reliable cold starting.

Spin-on fuel filter and full-flow lubricating oil filter.

Top mounted Holset HX35 turbocharger for increased power, fuel economy, and lower smoke and noise levels.

Service and Support - G-Drive products are backed by an uncompromising level of technical support and after sales service, delivered through a world class service network.

1500 rpm (50 Hz) Ratings

Gross Engine Output			Net Engine Output			Typical Generator Set Output					
Standby	Prime	Base	Standby	Prime	Base	Standby (ESP)		Prime (PRP)		Base (COP)	
kWm/BHP			kWm/BHP			kWe	kVA	kWe	kVA	kWe	kVA
107/143	97/130	56/75	104/140	94/127	53/72	95	119	86	107	48	60

1800 rpm (60 Hz) Ratings

Gross Engine Output			Net Engine Output			Typical Generator Set Output					
Standby	Prime	Base	Standby	Prime	Base	Standby (ESP)		Prime (PRP)		Base (COP)	
kWm/BHP			kWm/BHP			kWe	kVA	kWe	kVA	kWe	kVA
127/170	115/155	75/100	124/168	111/149	71/96	110	138	100	125	65	81

Our energy working for you.™

www.cumminsdrive.com

©2007 | Cummins G-Drive Engines | Specifications subject to change without notice | Cummins are registered trademarks of Cummins Inc. (01/08) (GDSS105-RevA)



General Engine Data

Type	4 cycle, in-line, Turbo Charged
Bore mm	102 mm (4.02 in.)
Stroke mm	120 mm (4.72 in.)
Displacement Litre	5.88 litre (359.0 in. ³)
Cylinder Block	Cast iron, 6 cylinder
Battery Charging Alternator	65 amps
Starting Voltage	12 volt, 65 Amp negative ground
Fuel System	Direct injection
Fuel Filter	Spin-on fuel filters with water separator
Lube Oil Filter Type(s)	Spin-on full flow filter
Lube Oil Capacity (l)	16.4
Flywheel Dimensions	3/11.5

Coolpac Performance Data

Cooling System Design	Jacket Water After Cooled
Coolant Ratio	50% ethlene glycol; 50% water
Coolant Capacity (l)	27.0
Limiting Ambient Temp.**	49.0
Fan Power	0.6
Cooling system air flow (m ³ /s)**	2.0
Air Cleaner Type	Dry replaceable element with retriiction indicator

** @ 13 mm H₂O

Weights & Dimension

Length	Width	Height	Weight (dry)
mm	mm	mm	kg
1248	700	1102	500

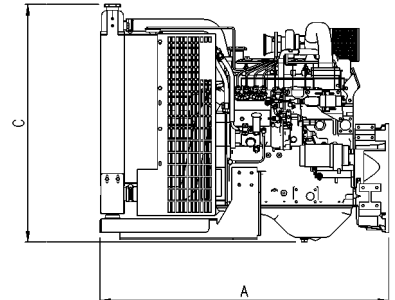
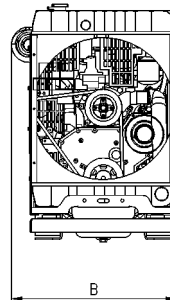

Fuel Consumption 1500 (50 Hz)

%	kWm	BHP	L/ph	US gal/ph
Standby Power				
100	107	143	27	7
Prime Power				
100	97	130	24	6.4
75	73	98	18	4.9
50	49	65	13	3.4
25	24	33	7	1.9
Continuous Power				
100	56	75	15	4

Fuel Consumption 1800 (60 Hz)

%	kWm	BHP	L/ph	US gal/ph
Standby Power				
100	127	170	31	8.2
Prime Power				
100	115	155	29	7.6
75	86	116	22	5.9
50	58	78	16	4.2
25	29	39	9	2.3
Continuous Power				
100	75	100	20	5.2

Cummins G-Drive Engines

Asia Pacific

10 Toh Guan Road
#07-01
TT International Tradepark
Singapore 608838
Phone 65 6417 2388
Fax 65 6417 2399

Europe, CIS, Middle

East and Africa
Manston Park Columbus Ave
Manston Ramsgate
Kent CT12 5BF. UK
Phone 44 1843 255000
Fax 44 1843 255902

Latin America

Rua Jati, 310, Cumbica
Guarulhos, SP 07180-900
Brazil
Phone 55 11 2186 4552
Fax 55 11 2186 4729

Mexico

Cummins S. de R.L. de C.V.
Eje 122 No. 200 Zona Industrial
San Luis Potosí, S.L.P. 78090
Mexico
Phone 52 444 870 6700
Fax 52 444 870 6811

North America

1400 73rd Avenue N.E.
Minneapolis, MN 55432
USA
Phone 1 763 574 5000
USA Toll-free 1 877 769 7669
Fax 1 763 574 5298

Our energy working for you.™

www.cumminsgdrive.com

©2007 | Cummins G-Drive Engines | Specifications subject to change without notice | Cummins are registered trademarks of Cummins Inc. (01/08) (GDSS105-RevA)

Ratings Definitions

Emergency Standby Power (ESP):

Applicable for supplying power to varying electrical load for the duration of power interruption of a reliable utility source. Emergency Standby Power (ESP) is in accordance with ISO 8528. Fuel Stop power in accordance with ISO 3046, AS 2789, DIN 6271 and BS 5514.

Limited-Time Running Power (LTP):

Applicable for supplying power to a constant electrical load for limited hours. Limited-Time Running Power (LTP) is in accordance with ISO 8528.

Prime Power (PRP):

Applicable for supplying power to varying electrical load for unlimited hours. Prime Power (PRP) is in accordance with ISO 8528. Ten percent overload capability is available in accordance with ISO 3046, AS 2789, DIN 6271 and BS 5514.

Base Load (Continuous) Power (COP):

Applicable for supplying power continuously to a constant electrical load for unlimited hours. Continuous Power (COP) in accordance with ISO 8528, ISO 3046, AS 2789, DIN6271 and BS 5514.



UCI274C - Technical Data Sheet

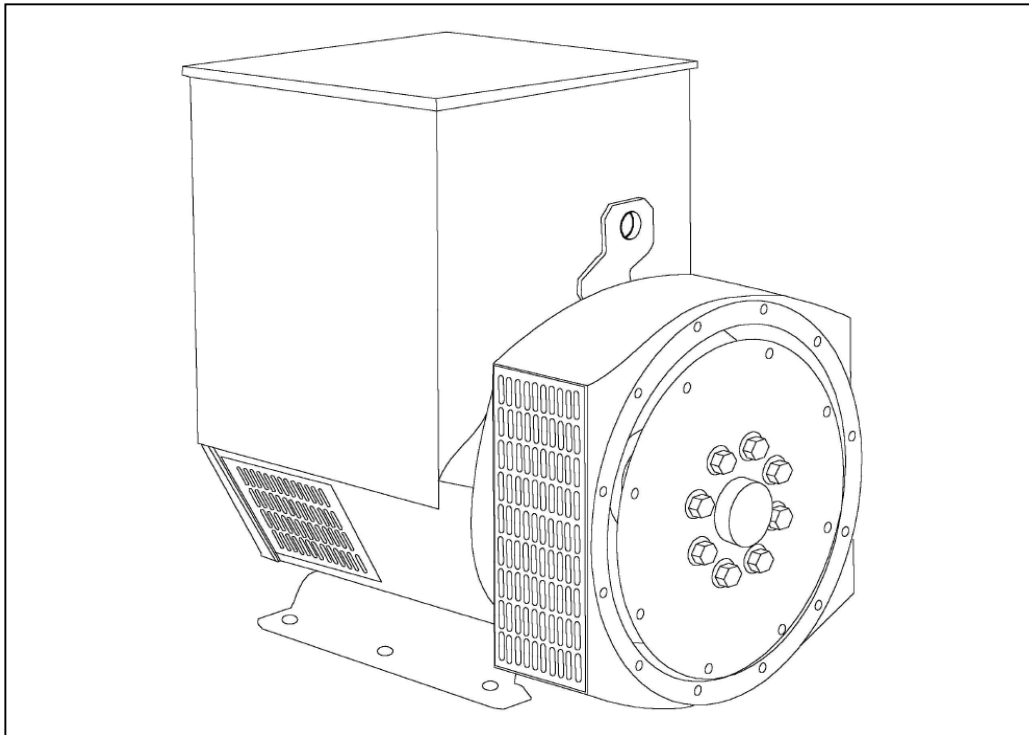

UCI274C

SPECIFICATIONS & OPTIONS



STANDARDS

Newage Stamford industrial generators meet the requirements of BS EN 60034 and the relevant section of other international standards such as BS5000, VDE 0530, NEMA MG1-32, IEC34, CSA C22.2-100, AS1359. Other standards and certifications can be considered on request.

VOLTAGE REGULATORS

SX460 AVR - STANDARD

With this self excited control system the main stator supplies power via the Automatic Voltage Regulator (AVR) to the exciter stator. The high efficiency semiconductors of the AVR ensure positive build-up from initial low levels of residual voltage.

The exciter rotor output is fed to the main rotor through a three phase full wave bridge rectifier. This rectifier is protected by a surge suppressor against surges caused, for example, by short circuit.

SX440 AVR

With this self-excited system the main stator provides power via the AVR to the exciter stator. The high efficiency semi-conductors of the AVR ensure positive build-up from initial low levels of residual voltage.

The exciter rotor output is fed to the main rotor through a three-phase full-wave bridge rectifier. The rectifier is protected by a surge suppressor against surges caused, for example, by short circuit or out-of-phase paralleling.

The SX440 will support a range of electronic accessories, including a 'droop' Current Transformer (CT) to permit parallel operation with other ac generators.

If 3-phase sensing is required with the self-excited system, the SX421 AVR must be used.

SX421AVR

This AVR also operates in a self-excited system. It combines all the features of the SX440 with, additionally, three-phase rms sensing for improved regulation and performance. Over voltage protection is provided via a separate circuit breaker. An engine relief load acceptance feature is built in as standard.

MX341 AVR

This sophisticated AVR is incorporated into the Stamford Permanent Magnet Generator (PMG) control system.

The PMG provides power via the AVR to the main exciter, giving a source of constant excitation power independent of generator output. The main exciter output is then fed to the main rotor, through a full wave bridge, protected by a surge suppressor. The AVR has in-built protection against sustained over-excitation, caused by internal or external faults. This de-excites the machine after a minimum of 5 seconds.

An engine relief load acceptance feature can enable full load to be applied to the generator in a single step.

If three-phase sensing is required with the PMG system the MX321 AVR must be used.

We recommend three-phase sensing for applications with greatly unbalanced or highly non-linear loads.

MX321 AVR

The most sophisticated of all our AVRs combines all the features of the MX341 with, additionally, three-phase rms sensing, for improved regulation and performance.

Over voltage protection is built-in and short circuit current level adjustments is an optional facility.

WINDINGS & ELECTRICAL PERFORMANCE

All generator stators are wound to 2/3 pitch. This eliminates triplen (3rd, 9th, 15th ...) harmonics on the voltage waveform and is found to be the optimum design for trouble-free supply of non-linear loads. The 2/3 pitch design avoids excessive neutral currents sometimes seen with higher winding pitches, when in parallel with the mains. A fully connected damper winding reduces oscillations during paralleling. This winding, with the 2/3 pitch and carefully selected pole and tooth designs, ensures very low waveform distortion.

TERMINALS & TERMINAL BOX

Standard generators are 3-phase reconnectable with 12 ends brought out to the terminals, which are mounted on a cover at the non-drive end of the generator. A sheet steel terminal box contains the AVR and provides ample space for the customers' wiring and gland arrangements. It has removable panels for easy access.

SHAFT & KEYS

All generator rotors are dynamically balanced to better than BS6861:Part 1 Grade 2.5 for minimum vibration in operation. Two bearing generators are balanced with a half key.

INSULATION/IMPREGNATION

The insulation system is class 'H'.

All wound components are impregnated with materials and processes designed specifically to provide the high build required for static windings and the high mechanical strength required for rotating components.

QUALITY ASSURANCE

Generators are manufactured using production procedures having a quality assurance level to BS EN ISO 9001.

The stated voltage regulation may not be maintained in the presence of certain radio transmitted signals. Any change in performance will fall within the limits of Criteria 'B' of EN 61000-6-2:2001. At no time will the steady-state voltage regulation exceed 2%.

NB Continuous development of our products entitles us to change specification details without notice, therefore they must not be regarded as binding.

UCI274C WINDING 311

CONTROL SYSTEM		SEPARATELY EXCITED BY P.M.G.							
A.V.R.		MX321	MX341						
VOLTAGE REGULATION		± 0.5 %	± 1.0 %	With 4% ENGINE GOVERNING					
SUSTAINED SHORT CIRCUIT		REFER TO SHORT CIRCUIT DECREMENT CURVES (page 7)							
CONTROL SYSTEM		SELF EXCITED							
A.V.R.		SX460	SX440	SX421					
VOLTAGE REGULATION		± 1.5 %	± 1.0 %	± 0.5 %	With 4% ENGINE GOVERNING				
SUSTAINED SHORT CIRCUIT		SERIES 4 CONTROL DOES NOT SUSTAIN A SHORT CIRCUIT CURRENT							
INSULATION SYSTEM		CLASS H							
PROTECTION		IP23							
RATED POWER FACTOR		0.8							
STATOR WINDING		DOUBLE LAYER CONCENTRIC							
WINDING PITCH		TWO THIRDS							
WINDING LEADS		12							
STATOR WDG. RESISTANCE		0.059 Ohms PER PHASE AT 22°C SERIES STAR CONNECTED							
ROTOR WDG. RESISTANCE		1.12 Ohms at 22°C							
R.F.I. SUPPRESSION		BS EN 61000-6-2 & BS EN 61000-6-4, VDE 0875G, VDE 0875N. refer to factory for others							
WAVEFORM DISTORTION		NO LOAD < 1.5% NON-DISTORTING BALANCED LINEAR LOAD < 5.0%							
MAXIMUM OVERSPEED		2250 Rev/Min							
BEARING DRIVE END		BALL. 6315-2RS (ISO)							
BEARING NON-DRIVE END		BALL. 6310-2RS (ISO)							
		1 BEARING				2 BEARING			
WEIGHT COMP. GENERATOR		406 kg				420 kg			
WEIGHT WOUND STATOR		131 kg				131 kg			
WEIGHT WOUND ROTOR		133.78 kg				122.82 kg			
WR ² INERTIA		1.0288 kgm ²				0.9781 kgm ²			
SHIPPING WEIGHTS in a crate		439 kg				452 kg			
PACKING CRATE SIZE		105 x 67 x 103(cm)				105 x 67 x 103(cm)			
		50 Hz				60 Hz			
TELEPHONE INTERFERENCE		THF<2%				TIF<50			
COOLING AIR		0.514 m ³ /sec 1090 cfm				0.617 m ³ /sec 1308 cfm			
VOLTAGE SERIES STAR		380/220	400/231	415/240	440/254	416/240	440/254	460/266	480/277
VOLTAGE PARALLEL STAR		190/110	200/115	208/120	220/127	208/120	220/127	230/133	240/138
VOLTAGE SERIES DELTA		220/110	230/115	240/120	254/127	240/120	254/127	266/133	277/138
KVA BASE RATING FOR REACTANCE VALUES		100	100	100	n/a	112.5	117.5	117.5	125
Xd DIR. AXIS SYNCHRONOUS		2.45	2.21	2.05	-	2.76	2.58	2.36	2.30
X'd DIR. AXIS TRANSIENT		0.20	0.18	0.17	-	0.24	0.22	0.21	0.20
X''d DIR. AXIS SUBTRANSIENT		0.14	0.13	0.12	-	0.16	0.15	0.14	0.13
Xq QUAD. AXIS REACTANCE		1.59	1.43	1.33	-	1.58	1.48	1.35	1.32
X''q QUAD. AXIS SUBTRANSIENT		0.18	0.16	0.15	-	0.23	0.21	0.20	0.19
Xl LEAKAGE REACTANCE		0.07	0.06	0.06	-	0.08	0.07	0.07	0.07
X2 NEGATIVE SEQUENCE		0.16	0.14	0.13	-	0.19	0.18	0.16	0.16
X0 ZERO SEQUENCE		0.10	0.09	0.08	-	0.12	0.11	0.10	0.10
REACTANCES ARE SATURATED				VALUES ARE PER UNIT AT RATING AND VOLTAGE INDICATED					
T'd TRANSIENT TIME CONST.		0.028 s							
T''d SUB-TRANSTIME CONST.		0.001 s							
T'do O.C. FIELD TIME CONST.		0.8 s							
Ta ARMATURE TIME CONST.		0.007 s							
SHORT CIRCUIT RATIO		1/Xd							

**50
Hz**

UCI274C
Winding 311



THREE PHASE EFFICIENCY CURVES

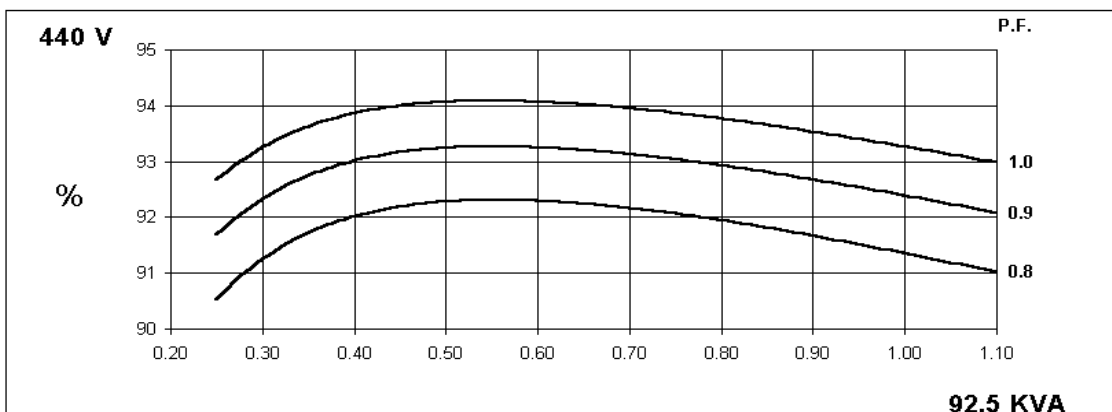
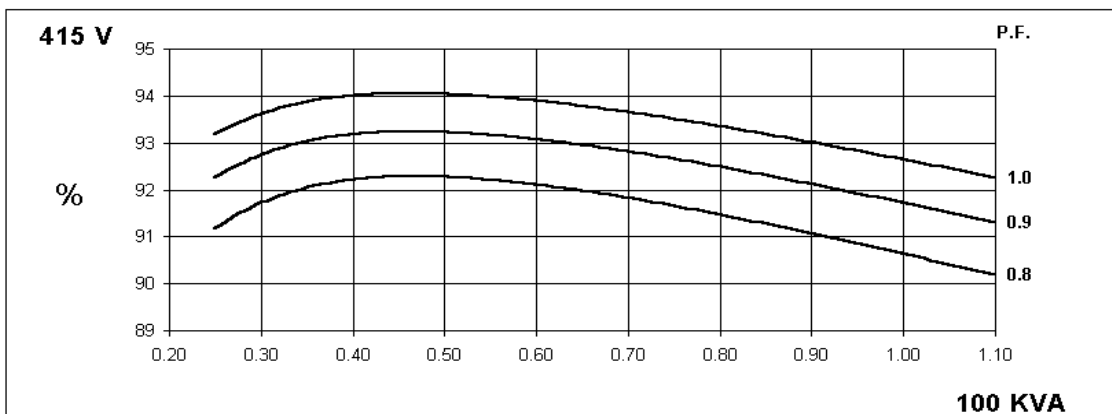
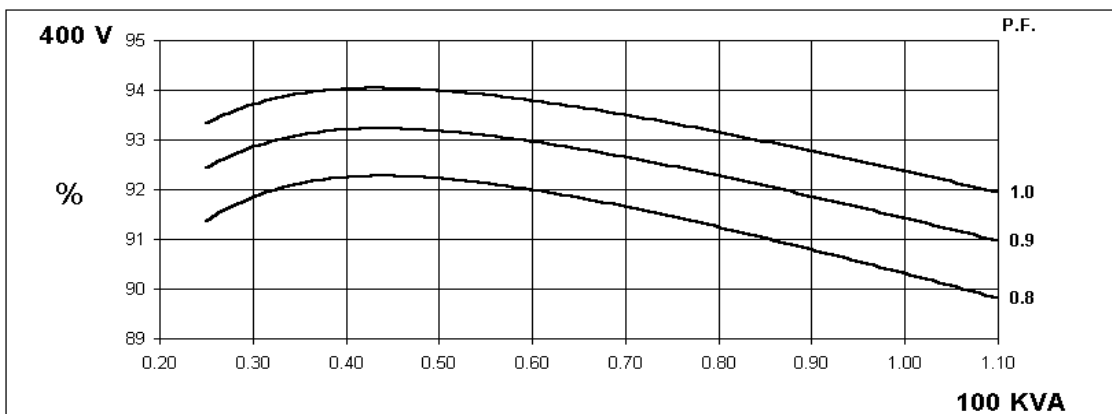
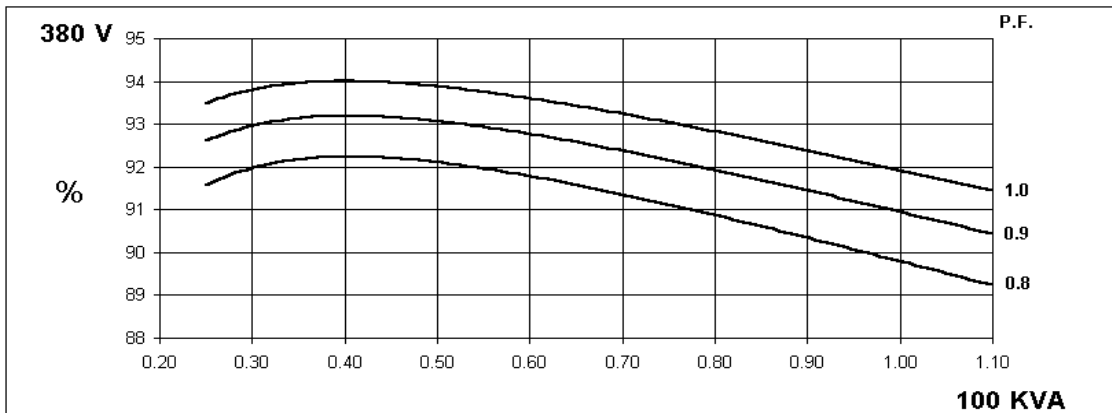

THREE PHASE EFFICIENCY CURVES

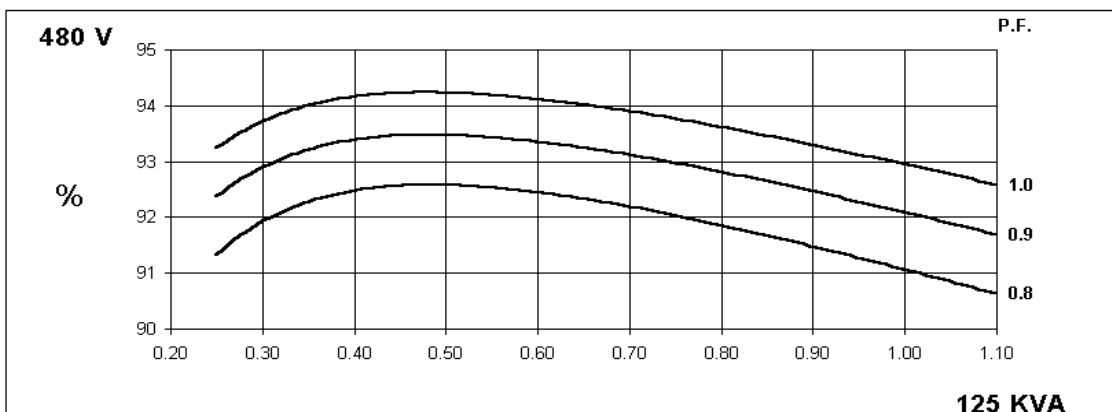
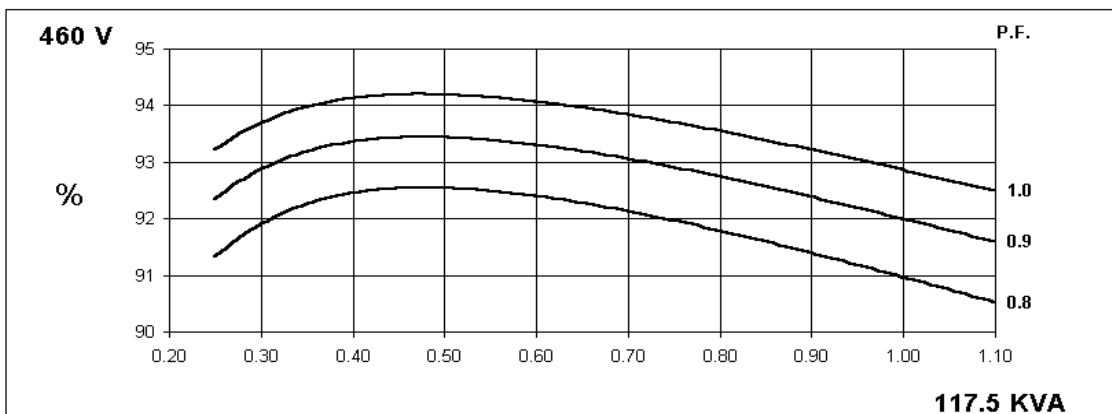
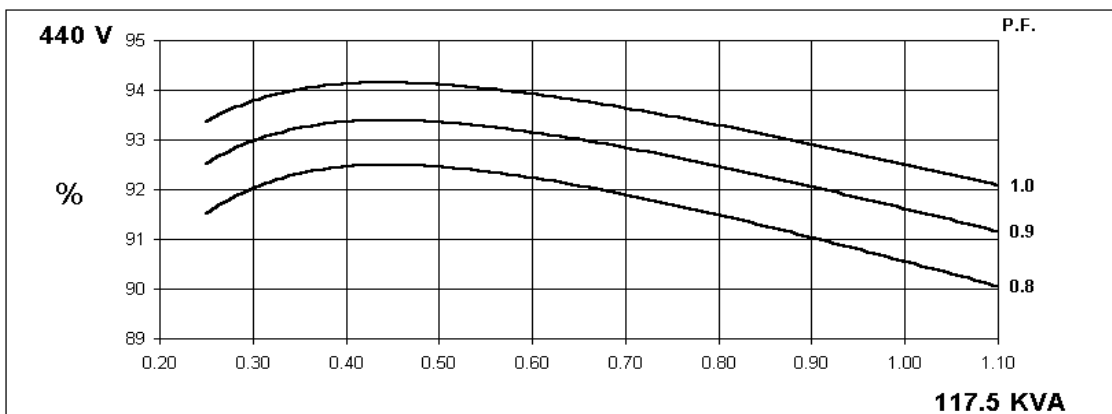
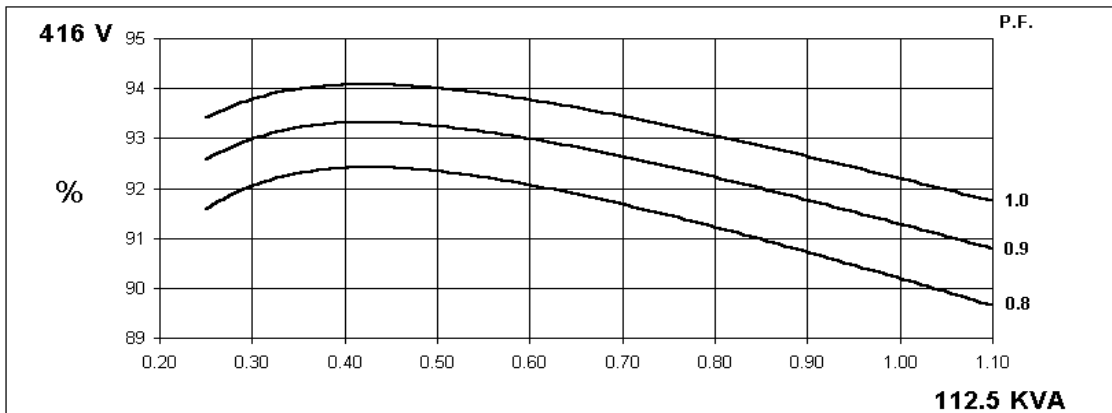

UCI274C

Winding 311



Locked Rotor Motor Starting Curve

**50
Hz**

MX

SX

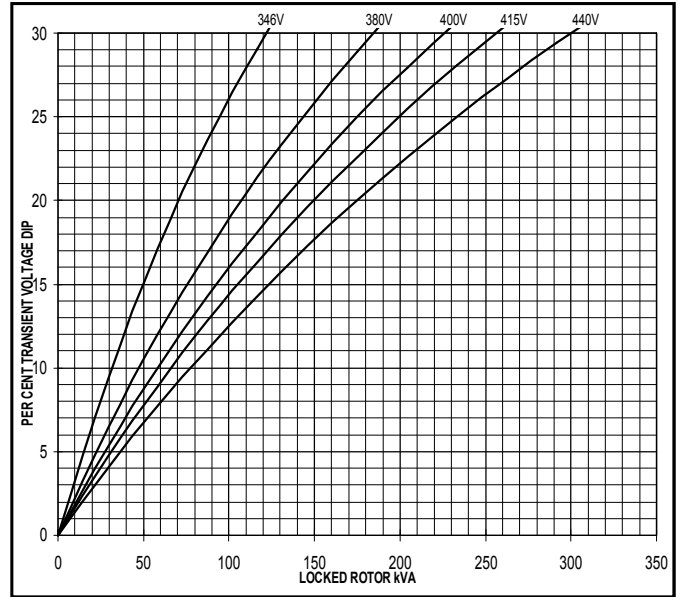
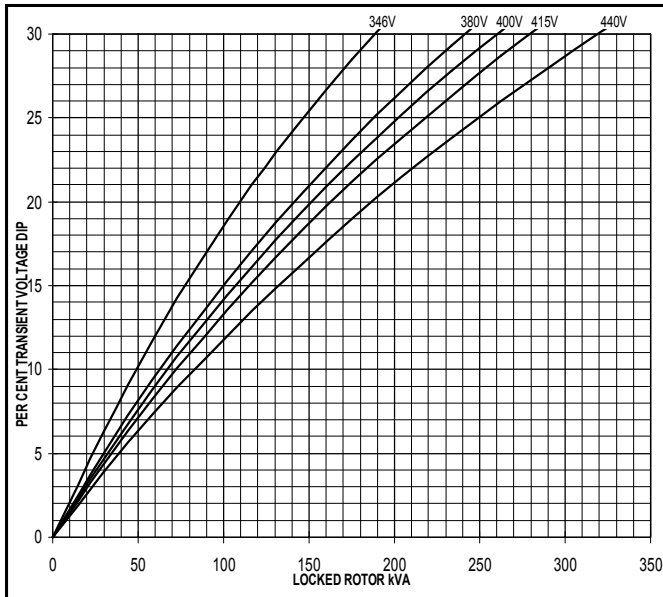

**60
Hz**

MX

SX

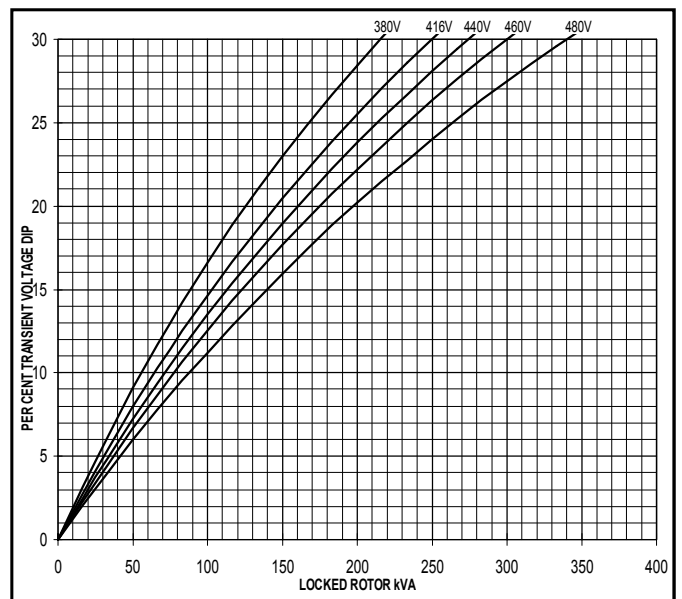
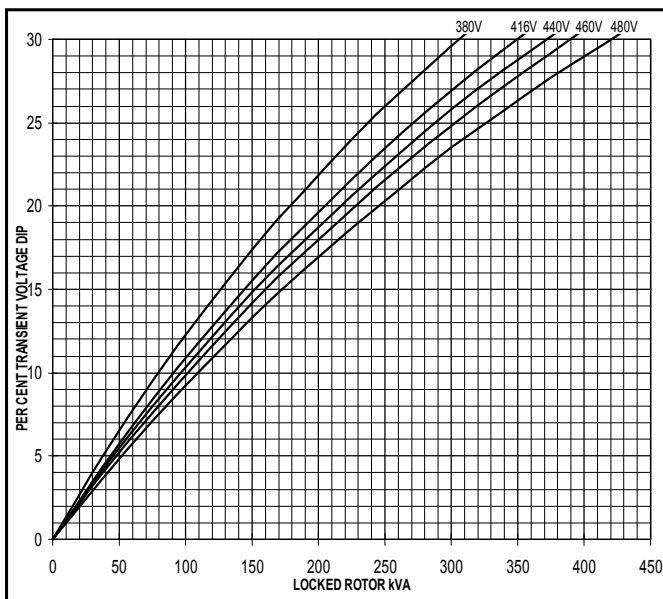

**Three-phase Short Circuit Decrement Curve. No-load Excitation at Rated Speed
Based on star (wye) connection.**

**50
Hz**

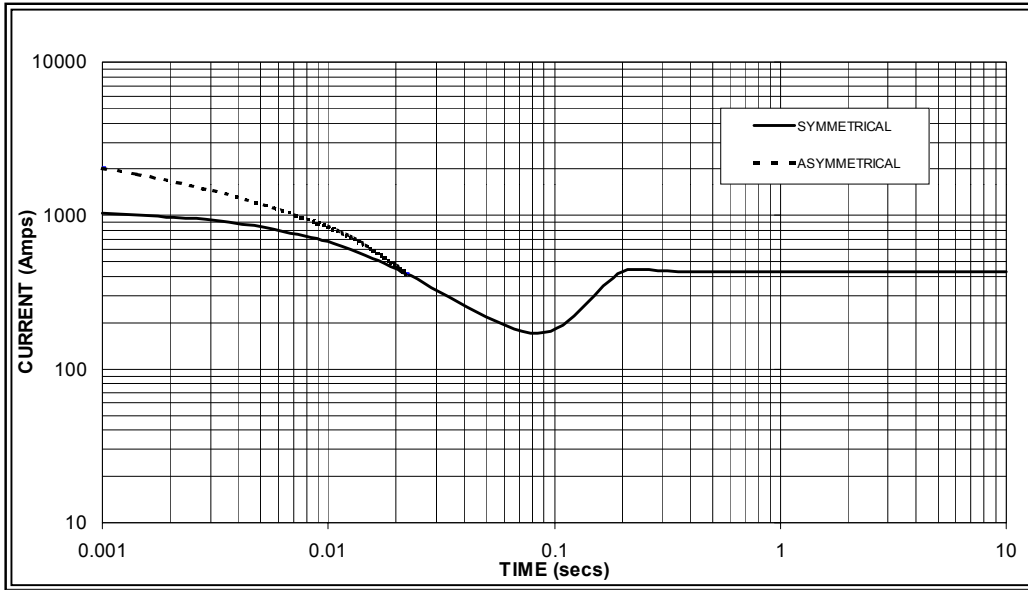

Sustained Short Circuit = 430 Amps

**60
Hz**

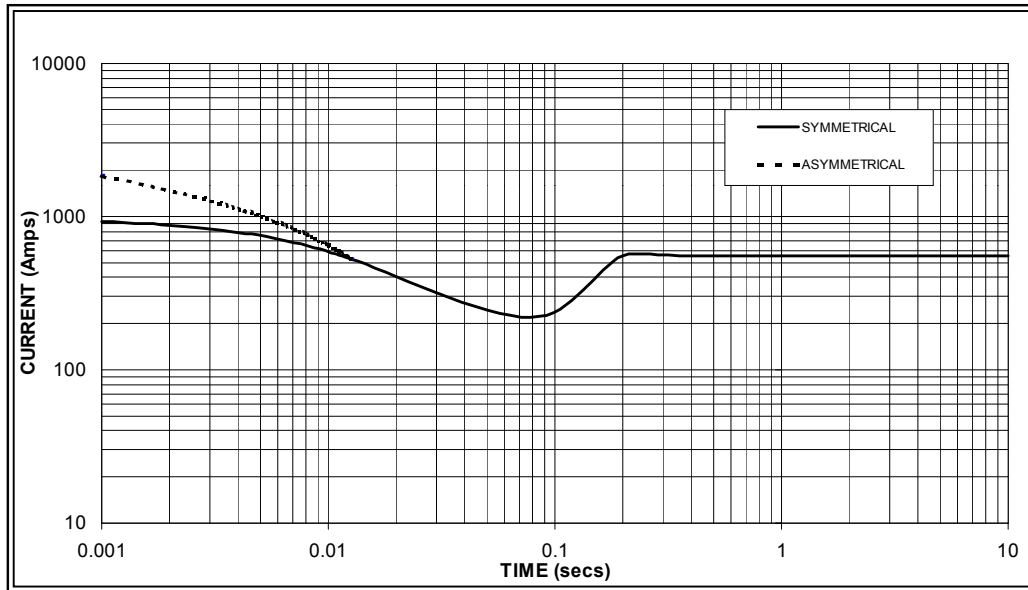

Sustained Short Circuit = 550 Amps

Note 1

The following multiplication factors should be used to adjust the values from curve between time 0.001 seconds and the minimum current point in respect of nominal operating voltage :

50Hz		60Hz	
Voltage	Factor	Voltage	Factor
380v	X 1.00	416v	X 1.00
400v	X 1.07	440v	X 1.06
415v	X 1.12	460v	X 1.12
440v	X 1.18	480v	X 1.17

The sustained current value is constant irrespective of voltage level

Note 2

The following multiplication factor should be used to convert the values calculated in accordance with NOTE 1 to those applicable to the various types of short circuit :

	3-phase	2-phase L-L	1-phase L-N
Instantaneous	x 1.00	x 0.87	x 1.30
Minimum	x 1.00	x 1.80	x 3.20
Sustained	x 1.00	x 1.50	x 2.50
Max. sustained duration	10 sec.	5 sec.	2 sec.

All other times are unchanged

Note 3

Curves are drawn for Star (Wye) connected machines. For other connection the following multipliers should be applied to current values as shown :

Parallel Star = Curve current value X 2

Series Delta = Curve current value X 1.732

UCI274C

Winding 311 / 0.8 Power Factor



RATINGS

Class - Temp Rise	Cont. F - 105/40°C				Cont. H - 125/40°C				Standby - 150/40°C				Standby - 163/27°C				
50 Hz	Series Star (V)	380	400	415	440	380	400	415	440	380	400	415	440	380	400	415	440
	Parallel Star (V)	190	200	208	220	190	200	208	220	190	200	208	220	190	200	208	220
	Series Delta (V)	220	230	240	254	220	230	240	254	220	230	240	254	220	230	240	254
kVA	84.0	84.0	84.0	n/a	100.0	100.0	100.0	n/a	106.0	106.0	106.0	n/a	110.0	110.0	110.0	n/a	
kW	67.2	67.2	67.2	n/a	80.0	80.0	80.0	n/a	84.8	84.8	84.8	n/a	88.0	88.0	88.0	n/a	
Efficiency (%)	90.7	91.1	91.3	n/a	89.8	90.3	90.6	n/a	89.5	90.0	90.4	n/a	89.2	89.8	90.2	n/a	
kW Input	74.1	73.8	73.6	n/a	89.1	88.6	88.3	n/a	94.7	94.2	93.8	n/a	98.7	98.0	97.6	n/a	

60 Hz	Series Star (V)	416	440	460	480	416	440	460	480	416	440	460	480	416	440	460	480
	Parallel Star (V)	208	220	230	240	208	220	230	240	208	220	230	240	208	220	230	240
	Series Delta (V)	240	254	266	277	240	254	266	277	240	254	266	277	240	254	266	277
kVA	97.5	106.3	106.3	112.5	112.5	117.5	117.5	125.0	116.3	125.0	125.0	132.5	120.0	127.5	127.5	137.5	
kW	78.0	85.0	85.0	90.0	90.0	94.0	94.0	100.0	93.0	100.0	100.0	106.0	96.0	102.0	102.0	110.0	
Efficiency (%)	90.9	91.0	91.4	91.5	90.2	90.6	91.0	91.1	90.0	90.2	90.7	90.8	89.8	90.1	90.6	90.6	
kW Input	85.8	93.5	93.0	98.4	99.8	103.8	103.3	109.8	103.4	110.9	110.3	116.7	106.9	113.2	112.6	121.4	

DIMENSIONS

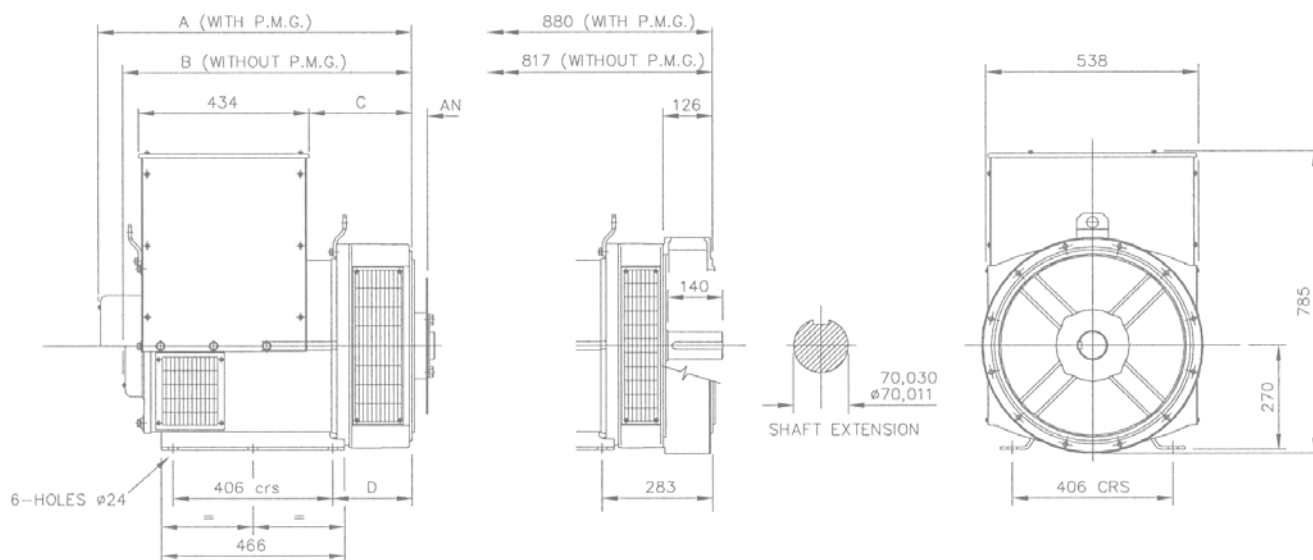

SINGLE BEARING ADAPTORS				
ADAPTOR	A	B	C	D
SAE 1	813,3	750,3	274,3	216,3
SAE 2	799	736	260	202
SAE 3	799	736	260	202

COUPLING DISCS	
DISC	AN
SAE 10	53,98
SAE 11,5	39,68
SAE 14	25,40



PO Box 17 • Barnack Road • Stamford • Lincolnshire • PE9 2NB

Tel: 00 44 (0)1780 484000 • Fax: 00 44 (0)1780 484100

Website: www.newage-avkseg.com